

# 5S-FE ENGINE

EG1-2

5S-FE ENGINE - ENGINE MECHANICAL

## ENGINE MECHANICAL

### DESCRIPTION

The 5S-FE engine is an in-line, 4-cylinder, 2.2 liter DOHC 16-valve engine.

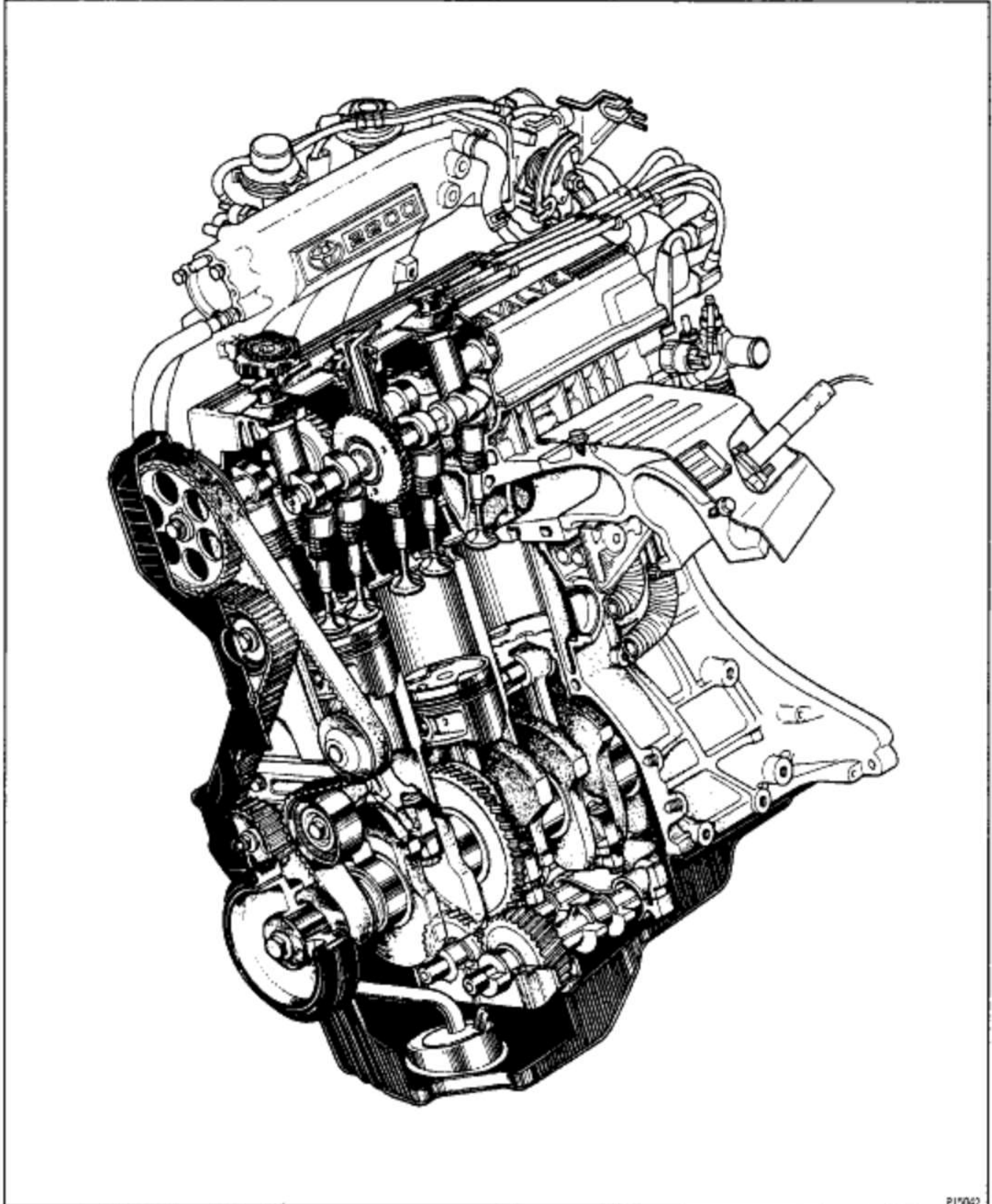

P12052

The 5S-FE engine is an in-line, 4-cylinder engine with the cylinders numbered 1-2-3-4 from the front. The crankshaft is supported by five bearings inside the crankcase. These bearings are made of aluminum alloy.

The crankshaft is integrated with eight weights for balance. Oil holes are placed in the center of the crankshaft to supply oil to the connecting rods, bearing, pistons and other components.

The firing order is 1-3-4-2. The cylinder head is made of aluminum alloy, with a cross flow type intake and exhaust layout and with pent-roof type combustion chambers. The spark plugs are located in the center of the combustion chambers.

The intake manifold has four independent long ports and utilizes the inertial supercharging effect to improve engine torque at low and medium speeds.

Exhaust and intake valves are equipped with irregular pitch springs made of special valve spring carbon steel which are capable of functioning no matter what the engine speed.

The intake camshaft is driven by a timing belt, and a gear on the intake camshaft engages with a gear on the exhaust camshaft to drive it. The cam journal is supported at five places between the valve lifters of each cylinder and on the front end of the cylinder head. Lubrication of the cam journals and gears is accomplished by oil being supplied through the oiler port in the center of the camshaft.

Adjustment of the valve clearance is done by means of an outer shim type system, in which valve adjusting shims are located above the valve lifters. This permits replacement of the shims without removal of the camshafts.

Pistons are made of high temperature-resistant aluminum alloy, and a depression is built into the piston head to prevent interference with the valves.

Piston pins are the full-floating type, with the pins fastened to neither the piston boss nor the connecting rods. Instead, snap rings are fitted on both ends of the pins, preventing the pins from falling out.

The No.1 compression ring is made of steel and the No.2 compression ring is made of cast iron. The oil ring is made of a combination of steel and stainless steel. The outer diameter of each piston ring is slightly larger than the diameter of the piston and the flexibility of the rings allows them to hug the cylinder walls when they are mounted on the piston. Compression rings No.1 and No.2 work to prevent gas leakage from the cylinder and the oil ring works to scrape oil off the cylinder walls to prevent it from entering the combustion chambers.

The cylinder block is made of cast iron. It has four cylinders which are approximately twice the length of the piston stroke. The top of each cylinder is closed off by the cylinder head and the lower end of the cylinders becomes the crankcase, in which the crankshaft is installed. In addition, the cylinder block contains a water jacket, through which coolant is pumped to cool the cylinders.

The oil pan is bolted onto the bottom of the cylinder block. The oil pan is an oil reservoir made of pressed sheet steel. A dividing plate is included inside the oil pan to keep sufficient oil in the bottom of the pan even when the vehicle is tilted. This dividing plate also prevents the oil from making waves when the vehicle is stopped suddenly and the oil shifts away from the oil pump suction pipe.

The 5S-FE engine uses two balance shafts. The balance shafts are fitted in balance shaft housings that are located at the bottom of the cylinder block. The No. 1 balance shaft is driven by the drive gear of the crankshaft No.3 counterweight at twice the speed of the crankshaft. The No. 2 balance shaft is driven by the No-1 balance shaft at the same speed in the same direction as the crankshaft. The balance shafts are designed to eliminate secondary inertia force from the engine, thereby reducing the engine noise (booming noise).











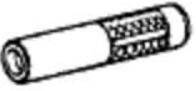

## EG1-4

## 5S-FE ENGINE - ENGINE MECHANICAL











## PREPARATION

## SST (SPECIAL SERVICE TOOLS)

SST-06



	09011-38121 12 mm Socket wrench for 12 Pointed Head	Cylinder head bolt and connecting rod bolt
	09201-41020 Valve Stem Oil Seal Replacer	
	09201-70010 Valve Guide Bushing Remover & Replacer	
	09202-70010 Valve Spring Compressor	
	09213-54015 Crankshaft Pulley Holding Tool	
	(91651 -60855) Bolt	
	09213-80017 Crankshaft Pulley & Gear Puller Set	
	(09213-00020) Body With Bolt	
	(09213-00030) Handle	
	(09213-00060) Bolt set	
	09222-30010 Connecting Rod Bushing Remover & Replacer	
	09223-46011 Crankshaft Front Oil Seal Replacer	Camshaft oil seal
	09223-63010 Crankshaft Rear Oil Seal Replacer	

## 5S-FE ENGINE - ENGINE MECHANICAL

	09224-74010 Engine Balancer Backlash Adjusting Tool	
	09248-55020 Valve Clearance Adjust Tool Set	
	(09248-05011) Valve Lifter Press	
	(09248-05021) Valve Lifter Stopper	
	09249-63010 Torque Wrench Adaptor	
	09226-10010 Crankshaft Front & Rear Bearing Replacer	
	09278-54012 Drive Shaft Holding Tool	Camshaft timing pulley
	09330-00021 Companion Flange Holding Tool	Crankshaft pulley
	09616-30011 Steering Worm Bearing Adjusting Screw Wrench	Oil pump pulley
	09816-30010 Oil Pressure Switch Socket	Knock sensor
	09843-18020 Diagnosis Check Wire	



## RECOMMENDED TOOLS

BWAZ-01

	09090-04010 Engine Sling Device	For suspension engine
	09200-00010 Engine Adjust Kit	

## EG1-6

## 5S-FE ENGINE - ENGINE MECHANICAL

	09256-00030 Hose Plug Set	Plug for vacuum hose, fuel hose etc.
	09904-00010 Expander Set	

## EQUIPMENT

E2400-51

Battery specific gravity gauge	
Caliper gauge	
CO/HC meter	
Compression gauge	
Connecting rod aligner	
Cylinder gauge	
Dial indicator	
Dye penetrant	
Engine tune-up tester	
Heater	
Magnetic finger	
Micrometer	
Piston ring compressor	
Piston ring expander	
Plastigage	
Precision straight edge	
Soft brush	
Spring tester	Valve spring
Steel square	Valve spring
Thermometer	
Torque wrench	

## 5S-FE ENGINE - ENGINE MECHANICAL

Valve seat cutter	
Vernier calipers	

**SSM (SERVICE SPECIAL MATERIALS)**

SSM-91

08826-00080 Seal packing or equivalent	Camshaft bearing cap Cylinder head cover Rear oil seal retainer
08833-00070 Adhesive 1311, THREE BOND 1311 or equivalent	Flywheel or drive plate bolt

## EG1-8

## 5S-FE ENGINE - ENGINE MECHANICAL

**TUNE-UP****ENGINE COOLANT INSPECTION****1. CHECK ENGINE COOLANT LEVEL AT RESERVOIR TANK**

The engine coolant level should be between the "LOW" and "FULL" lines at low temperature. If low, check for leaks and add engine coolant up to the "FULL"

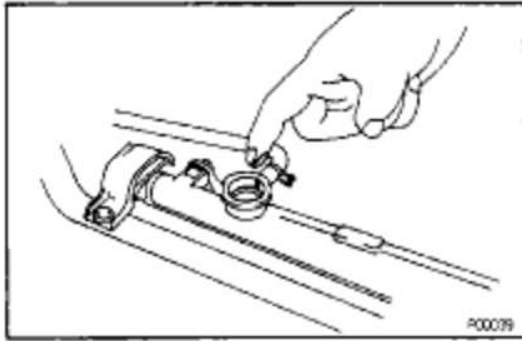
**2. CHECK ENGINE COOLANT QUALITY**

There should be no excessive deposits of rust or scales around the radiator cap or radiator filler hole, and the engine coolant should be free from oil. If excessively dirty, replace the engine coolant.

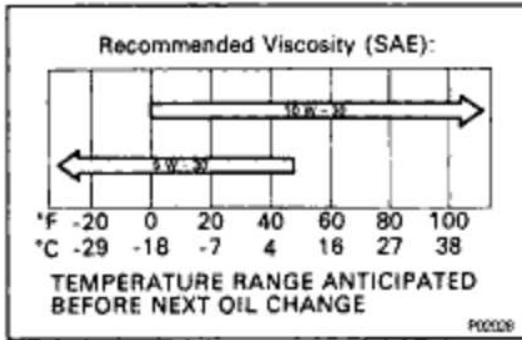
**ENGINE OIL INSPECTION****1. CHECK OIL QUALITY**

Check the oil for deterioration, entry of water, discoloring or thinning.

If oil quality is visibly poor, replace it.

**Oil grade:**

**API grade SG or SH, Energy Conserving II multi-grade engine oil or ILSAC multigrade engine oil.**

**Recommended viscosity is as shown in the illustration.**

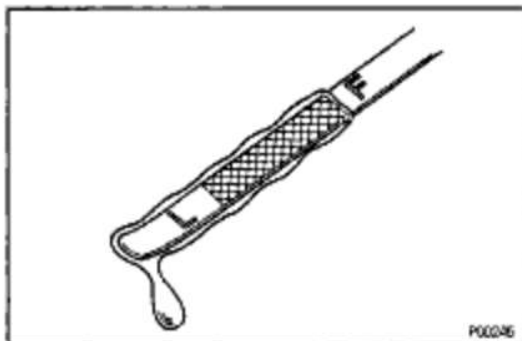
**2. CHECK ENGINE OIL LEVEL**

The oil level should be between the "L" and "F" marks on the dipstick.

If low, check for leakage and add oil up to the "F" mark.



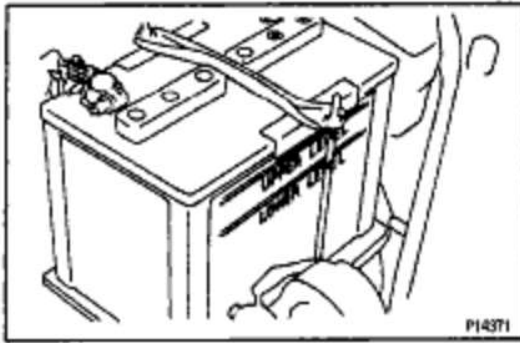

## BATTERY INSPECTION

### 1. Except Delco Battery:

#### CHECK BATTERY ELECTROLYTE LEVEL

Check the electrolyte quantity of each cell.

#### A. Maintenance Free Battery

If under the lower level, replace the battery (or add distilled water if possible). Check the charging system.

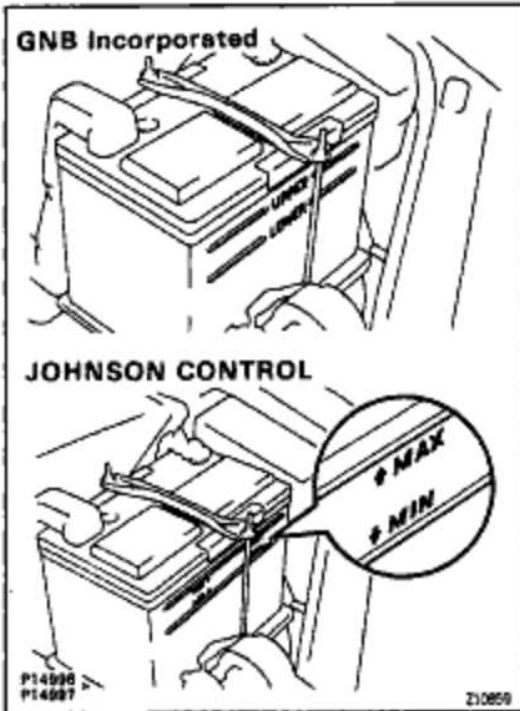

### B. Except Maintenance Free Battery

If under the "LOWER" or "MIN" line, add distilled water.

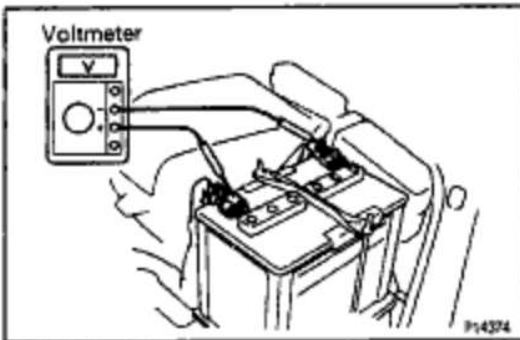

### 2. Except Delco Battery:

#### CHECK BATTERY VOLTAGE AND SPECIFIC GRAVITY

#### A. Maintenance Free Battery

Measure the battery voltage between the terminals negative (-) and positive (+) of the battery.

#### Standard voltage:

12.7 - 12.9 V at 20°C (68°F)

#### HINT:

- Before measuring the voltage, turn the ignition switch to LOCK and turn off the electrical systems (headlight, blower motor, rear defogger etc.) for 60 seconds to remove the surface charge.
- If the vehicle has been running, wait 5 minutes or more after the vehicle stops before measuring the battery voltage.

If the voltage is less than specification, charge the battery.

HINT: Check the indicator as shown in the illustration.

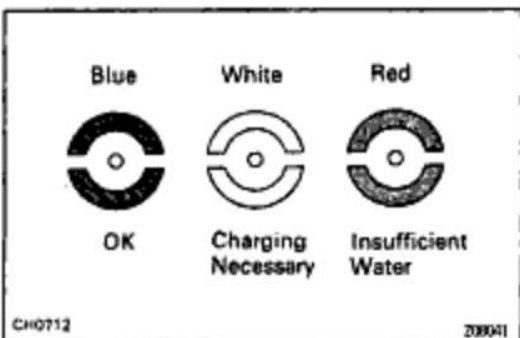

## EG1-10

## 5S-FE ENGINE - ENGINE MECHANICAL

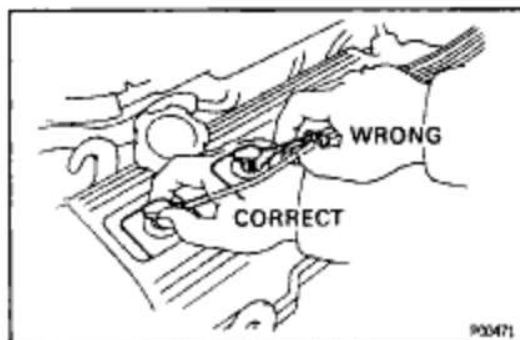
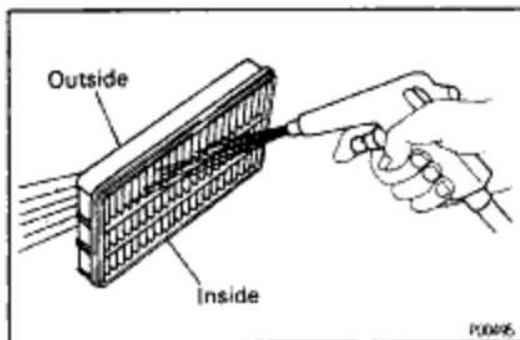
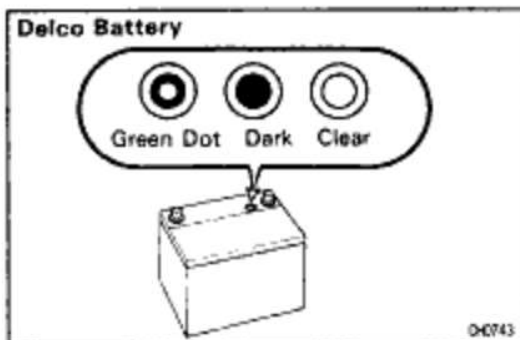
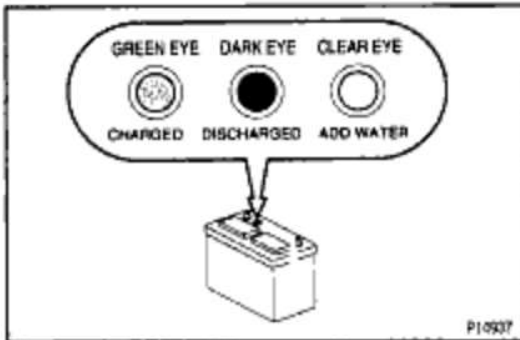
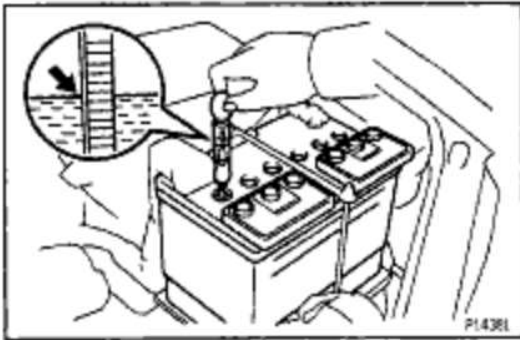
**B. Except Maintenance Free Battery**

Check the specific gravity of each cell.

**Standard specific gravity:**

**55D23L battery for GNB Incorporated**

1.25 – 1.27 at 20°C (68°F)

**55D23L battery for JOHNSON CONTROLS**

1.26 – 1.28 at 27°C (81°F)

**80D26L battery for GNB Incorporated**

1.27 – 1.29 at 20°C (68°F)

**80D26L battery for JOHNSON CONTROLS**

1.28 – 1.30 at 27°C (81°F)

If the gravity is less than specification, charge the battery.

HINT: Check the indicator as shown in the illustration.

**3. Delco Battery:****CHECK HYDROMETER**

**Green Dot visible:**

**Battery is adequately charged**

**Dark (Green Dot not visible):**

**Battery must be charged**

**Clear or Light Yellow:**

**Replace battery**

HINT: There is no need to add water during the entire service life of the battery.

**AIR FILTER INSPECTION****1. INSPECT AIR FILTER**

Visually check that the element is not excessively dirty, damaged or oily.

**2. CLEAN AIR FILTER**

Clean the element with compressed air.

First blow air from the inside thoroughly. Then blow off the outside of the element.

**HIGH-TENSION CORDS INSPECTION****1. DISCONNECT HIGH-TENSION CORDS FROM SPARK PLUGS**

Disconnect the high – tension cords at the rubber boot. Do not pull on the high-tension cords.

**NOTICE:** Pulling on or bending the cords may damage the conductor inside.

2. CALIFORNIA ONLY:  
DISCONNECT HIGH-TENSION CORD FROM  
IGNITION COIL
3. DISCONNECT HIGH -TENSION CORDS FROM  
DISTRIBUTOR CAP

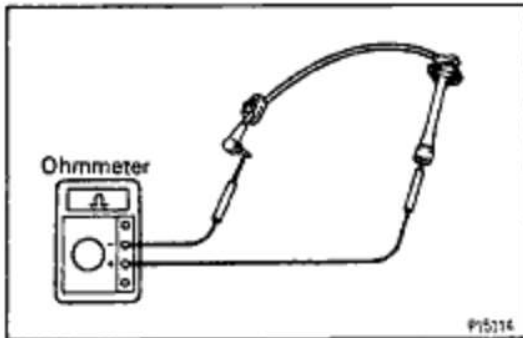

#### 4. INSPECT HIGH-TENSION CORD RESISTANCE

Using an ohmmeter, measure the resistance.

**Maximum resistance:**

**25 k $\Omega$  per cord**

If the resistance is greater than maximum, check the terminals. If necessary, replace the high - tension cord.

#### 5. RECONNECT HIGH-TENSION CORDS TO DISTRIBUTOR CAP

#### 6. CALIFORNIA ONLY: RECONNECT HIGH-TENSION CORD TO IGNITION COIL

#### 7. RECONNECT HIGH-TENSION CORDS TO SPARK PLUGS

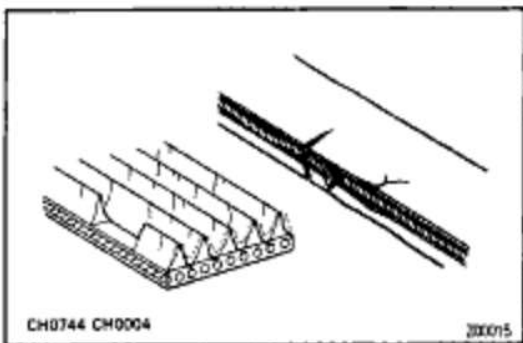

## GENERATOR DRIVE BELT INSPECTION

### INSPECT DRIVE BELT

- (a) Visually check the drive belt for excessive wear, frayed cords etc.

If any defect has been found, replace the drive belt.

HINT: Cracks on the rib side of a drive belt are considered acceptable. If the drive belt has chunks missing from the ribs, it should be replaced.

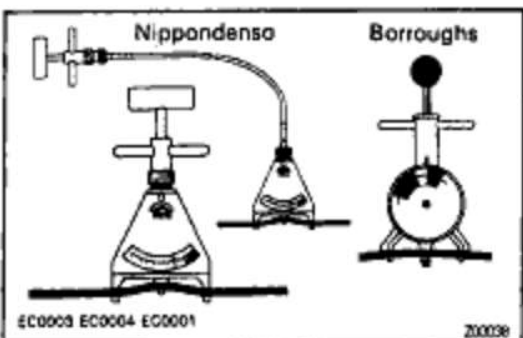

- (b) Using a belt tension gauge, measure the belt tension.

Belt tension gauge:

Nippondenso BTG-20 (95506-00020)

Borroughs No. BT-33-73F

## EG1-12

## 5S-FE ENGINE – ENGINE MECHANICAL

**Drive belt tension:****w/ A/C****New belt****175 ± 5 lbf****Used belt****130 ± 10 lbf****w/o A/C****New belt****125 ± 25 lbf****Used belt****95 ± 20 lbf**

If the belt tension is not as specified, adjust it.

**HINT:**

- “New belt” refers to a belt which has been used less than 5 minutes on a running engine.
- “Used belt” refers to a belt which has been used on a running engine for 5 minutes or more.
- After installing a belt, check that it fits properly in the ribbed grooves.
- Check with your hand to confirm that the belt has not slipped out of the groove on the bottom of the pulley.
- After installing a new belt, run the engine for about 5 minutes and recheck the belt tension.

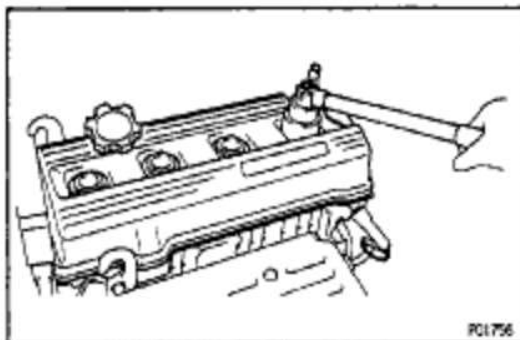
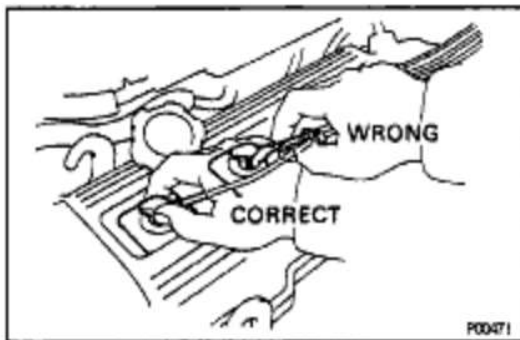
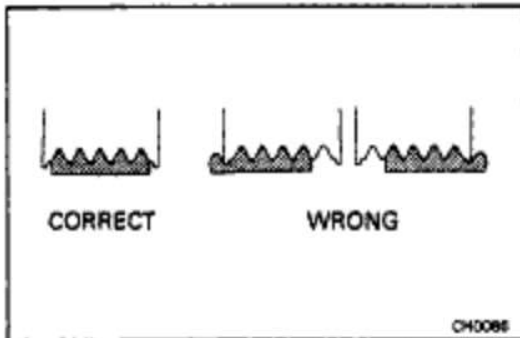

## VALVE CLEARANCE INSPECTION AND ADJUSTMENT

HINT: Inspect and adjust the valve clearance when the engine is cold.

### 1. DISCONNECT HIGH – TENSION CORDS FROM SPARK PLUGS

Disconnect the high – tension cords at the rubber boot. DO NOT pull on the cords.

**NOTICE:** Pulling on or bending the cords may damage the conductor inside.

### 2. REMOVE CYLINDER HEAD COVER

- Disconnect the PCV hoses.
- Loosen the 2 wire harness clamp bolts (No.2 timing belt cover) mounting bolts.
- Remove the 4 nuts, grommets, head cover and gasket.

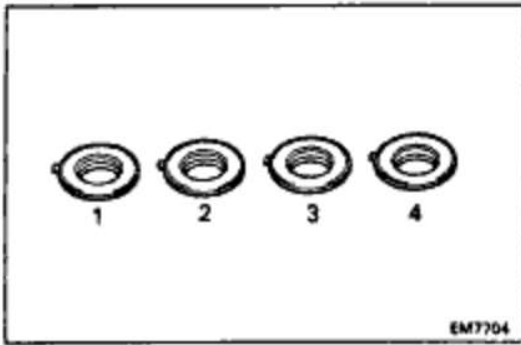

HINT: Arrange the grommets in correct order, so that they can be reinstalled into their original positions. This minimizes any possibility of oil leakage due to reuse of grommets.

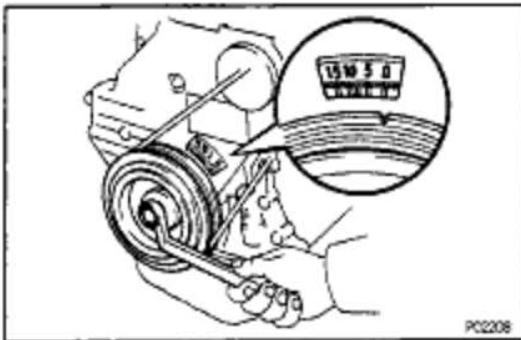

### 3. SET NO.1 CYLINDER TO TDC/COMPRESSION

- (a) Turn the crankshaft pulley and align its groove with timing mark "0" of the No.1 timing belt cover.
- (b) Check that the valve lifters on the No.1 cylinder are loose and valve lifters on the No.4 are tight. If not, turn the crankshaft one revolution (360°) and align the mark as above.

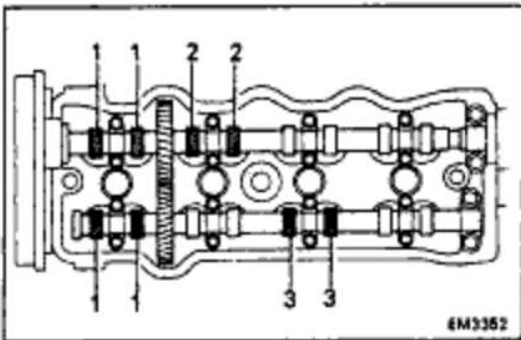

### 4. INSPECT VALVE CLEARANCE

- (a) Check only the valves indicated. Using a thickness gauge, measure the clearance between the valve lifter and camshaft. Record the out- of -specification valve clearance measurements. They will be used later to determine the required replacement adjusting shim.

#### Valve clearance (Cold):

##### Intake

0.19 – 0.29 mm (0.007 – 0.011 in.)

##### Exhaust

0.28 – 0.38 mm (0.011 – 0.015 in.)

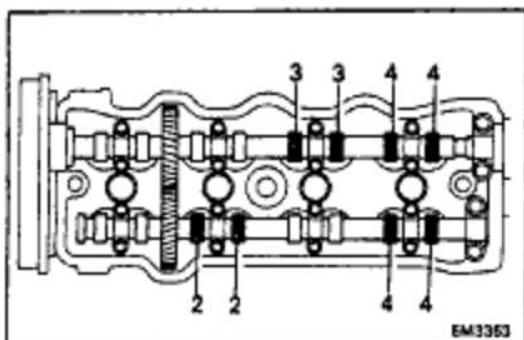

- (b) Turn the crankshaft one revolution (360°) and align the mark as above. (See procedure in step 3)
- (c) Check only the valves indicated as shown. Measure the valve clearance. (See procedure in step (a))

## EG1-14

## 5S-FE ENGINE – ENGINE MECHANICAL

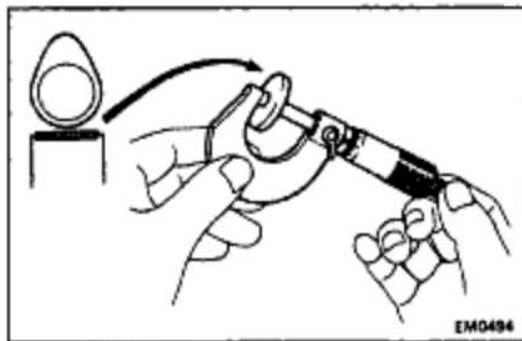
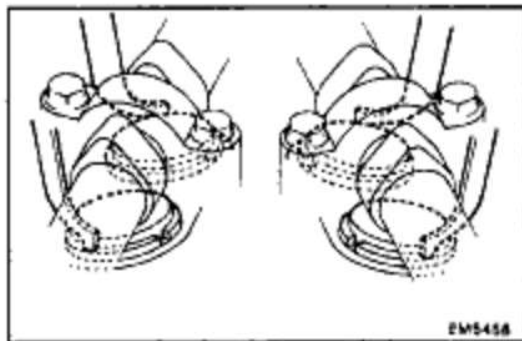
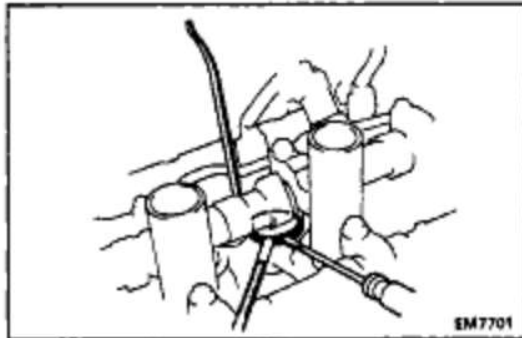
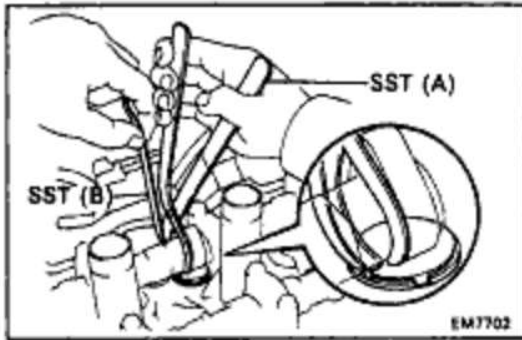

## 5. ADJUST VALVE CLEARANCE

(a) Remove the adjusting shim.

- Turn the crankshaft so that the cam lobe for the valve to be adjusted faces up.
- Using SST (A), press down the valve lifter and place SST (B) between the camshaft and valve lifter. Remove SST (A).

SST 09248 – 55020 (09248 – 05011, 09248–05021)

HINT: Before pressing down the valve lifter, position its notch toward the spark plug side.

- Remove the adjusting shim with a small screwdriver and magnetic finger.

HINT: For easy removed of the shim, when positioning SST (B), set it on the lifter so there is space enough to be able to remove the shim.

(b) Determine the replacement adjusting shim size by following the Formula or Charts:

- Using a micrometer, measure the thickness of the removed shim.
  - Calculate the thickness of a new shim so that the valve clearance comes within specified value.
- T ..... Thickness of removed shim  
 A ..... Measured valve clearance  
 N ..... Thickness of new shim

**Intake:**

$$N = T + (A - 0.24 \text{ mm (0.009 in.)})$$

**Exhaust:**

$$N = T + (A - 0.33 \text{ mm (0.013 in.)})$$

- Select a new shim with a thickness as close as possible to the calculated value.

HINT: Shims are available in seventeen sizes in increments of 0.05 mm (0.0020 in.), from 2.50 mm (0.0984 in.) to 3.30 mm (0.1299 in.).

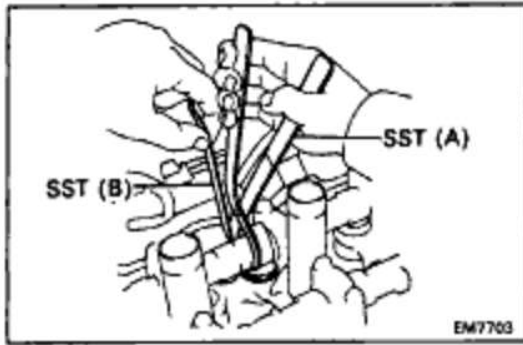

(c) Install a new adjusting shim.

- Place a new adjusting shim on the valve lifter.
- Using SST (A), press down the valve lifter and remove SST (B).

SST 09248-50020 (09248-05011, 09248-05021)

(d) Recheck the valve clearance.

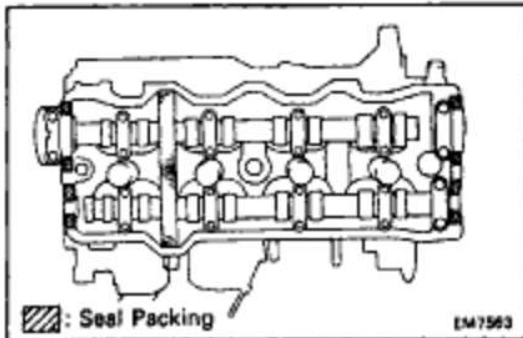

## 6. REINSTALL CYLINDER HEAD COVER

(a) Remove any old packing (FIPG) material.

(b) Apply seal packing to the cylinder head as shown in the illustration.

**Seal pecking:**

**Part No.08826-00080 or equivalent**

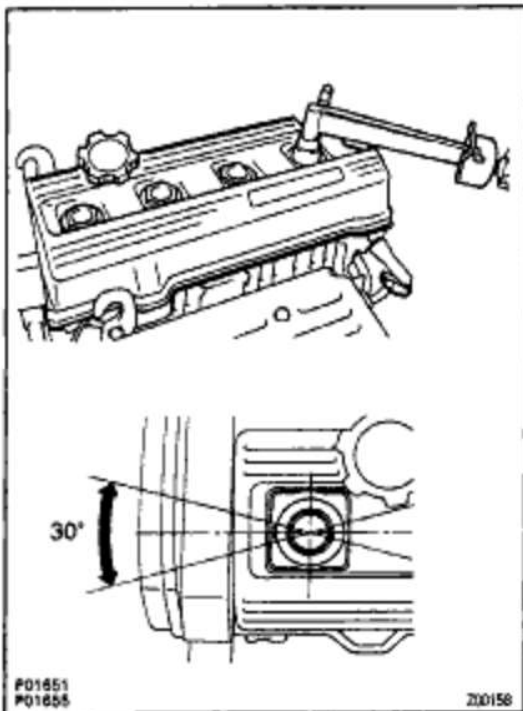

(c) Install the gasket to the head cover.

(d) Install the head cover with the 4 grommets and nuts. Uniformly tighten the nuts in several passes.

**Torque: 23 N-m (230 kgf-cm. 17 ft-lbf)**

**HINT:** Install the grommets so that their markings are as shown in the illustration.

(e) Tighten the 2 wire harness clamp (No.2 timing belt cover) mounting bolts.

(f) Connect the PCV hoses.

## 7. RECONNECT HIGH-TENSION CORDS TO SPARK PLUGS

EG1-16

5S-FE ENGINE - FE ENGINE - ENGINE MECHANICAL

Adjusting Shim Selection Chart (Intake)

Measured clearance mm (in.)	Installed shim thickness mm (in.)	250 (0.0984)	252 (0.0992)	254 (0.1000)	256 (0.1008)	258 (0.1016)	259 (0.1024)	260 (0.1032)	261 (0.1040)	262 (0.1048)	263 (0.1056)	264 (0.1064)	265 (0.1072)	266 (0.1080)	267 (0.1088)	268 (0.1096)	269 (0.1104)	270 (0.1112)	271 (0.1120)	272 (0.1128)	273 (0.1136)	274 (0.1144)	275 (0.1152)	276 (0.1160)	277 (0.1168)	278 (0.1176)	279 (0.1184)	280 (0.1192)	281 (0.1200)	282 (0.1208)	283 (0.1216)	284 (0.1224)	285 (0.1232)	286 (0.1240)	287 (0.1248)	288 (0.1256)	289 (0.1264)	290 (0.1272)	291 (0.1280)	292 (0.1288)	293 (0.1296)	294 (0.1304)	295 (0.1312)	296 (0.1320)	297 (0.1328)	298 (0.1336)	299 (0.1344)	300 (0.1352)	301 (0.1360)	302 (0.1368)	303 (0.1376)	304 (0.1384)	305 (0.1392)	306 (0.1400)	307 (0.1408)	308 (0.1416)	309 (0.1424)	310 (0.1432)	311 (0.1440)	312 (0.1448)	313 (0.1456)	314 (0.1464)	315 (0.1472)	316 (0.1480)	317 (0.1488)	318 (0.1496)	319 (0.1504)	320 (0.1512)	321 (0.1520)	322 (0.1528)	323 (0.1536)	324 (0.1544)	325 (0.1552)	326 (0.1560)	327 (0.1568)	328 (0.1576)	329 (0.1584)	330 (0.1592)	331 (0.1600)	332 (0.1608)	333 (0.1616)	334 (0.1624)	335 (0.1632)	336 (0.1640)	337 (0.1648)	338 (0.1656)	339 (0.1664)	340 (0.1672)	341 (0.1680)	342 (0.1688)	343 (0.1696)	344 (0.1704)	345 (0.1712)	346 (0.1720)	347 (0.1728)	348 (0.1736)	349 (0.1744)	350 (0.1752)	351 (0.1760)	352 (0.1768)	353 (0.1776)	354 (0.1784)	355 (0.1792)	356 (0.1800)	357 (0.1808)	358 (0.1816)	359 (0.1824)	360 (0.1832)	361 (0.1840)	362 (0.1848)	363 (0.1856)	364 (0.1864)	365 (0.1872)	366 (0.1880)	367 (0.1888)	368 (0.1896)	369 (0.1904)	370 (0.1912)	371 (0.1920)	372 (0.1928)	373 (0.1936)	374 (0.1944)	375 (0.1952)	376 (0.1960)	377 (0.1968)	378 (0.1976)	379 (0.1984)	380 (0.1992)	381 (0.2000)	382 (0.2008)	383 (0.2016)	384 (0.2024)	385 (0.2032)	386 (0.2040)	387 (0.2048)	388 (0.2056)	389 (0.2064)	390 (0.2072)	391 (0.2080)	392 (0.2088)	393 (0.2096)	394 (0.2104)	395 (0.2112)	396 (0.2120)	397 (0.2128)	398 (0.2136)	399 (0.2144)	400 (0.2152)	401 (0.2160)	402 (0.2168)	403 (0.2176)	404 (0.2184)	405 (0.2192)	406 (0.2200)	407 (0.2208)	408 (0.2216)	409 (0.2224)	410 (0.2232)	411 (0.2240)	412 (0.2248)	413 (0.2256)	414 (0.2264)	415 (0.2272)	416 (0.2280)	417 (0.2288)	418 (0.2296)	419 (0.2304)	420 (0.2312)	421 (0.2320)	422 (0.2328)	423 (0.2336)	424 (0.2344)	425 (0.2352)	426 (0.2360)	427 (0.2368)	428 (0.2376)	429 (0.2384)	430 (0.2392)	431 (0.2400)	432 (0.2408)	433 (0.2416)	434 (0.2424)	435 (0.2432)	436 (0.2440)	437 (0.2448)	438 (0.2456)	439 (0.2464)	440 (0.2472)	441 (0.2480)	442 (0.2488)	443 (0.2496)	444 (0.2504)	445 (0.2512)	446 (0.2520)	447 (0.2528)	448 (0.2536)	449 (0.2544)	450 (0.2552)	451 (0.2560)	452 (0.2568)	453 (0.2576)	454 (0.2584)	455 (0.2592)	456 (0.2600)	457 (0.2608)	458 (0.2616)	459 (0.2624)	460 (0.2632)	461 (0.2640)	462 (0.2648)	463 (0.2656)	464 (0.2664)	465 (0.2672)	466 (0.2680)	467 (0.2688)	468 (0.2696)	469 (0.2704)	470 (0.2712)	471 (0.2720)	472 (0.2728)	473 (0.2736)	474 (0.2744)	475 (0.2752)	476 (0.2760)	477 (0.2768)	478 (0.2776)	479 (0.2784)	480 (0.2792)	481 (0.2800)	482 (0.2808)	483 (0.2816)	484 (0.2824)	485 (0.2832)	486 (0.2840)	487 (0.2848)	488 (0.2856)	489 (0.2864)	490 (0.2872)	491 (0.2880)	492 (0.2888)	493 (0.2896)	494 (0.2904)	495 (0.2912)	496 (0.2920)	497 (0.2928)	498 (0.2936)	499 (0.2944)	500 (0.2952)
--------------------------------	--------------------------------------	--------------	--------------	--------------	--------------	--------------	--------------	--------------	--------------	--------------	--------------	--------------	--------------	--------------	--------------	--------------	--------------	--------------	--------------	--------------	--------------	--------------	--------------	--------------	--------------	--------------	--------------	--------------	--------------	--------------	--------------	--------------	--------------	--------------	--------------	--------------	--------------	--------------	--------------	--------------	--------------	--------------	--------------	--------------	--------------	--------------	--------------	--------------	--------------	--------------	--------------	--------------	--------------	--------------	--------------	--------------	--------------	--------------	--------------	--------------	--------------	--------------	--------------	--------------	--------------	--------------	--------------	--------------	--------------	--------------	--------------	--------------	--------------	--------------	--------------	--------------	--------------	--------------	--------------	--------------	--------------	--------------	--------------	--------------	--------------	--------------	--------------	--------------	--------------	--------------	--------------	--------------	--------------	--------------	--------------	--------------	--------------	--------------	--------------	--------------	--------------	--------------	--------------	--------------	--------------	--------------	--------------	--------------	--------------	--------------	--------------	--------------	--------------	--------------	--------------	--------------	--------------	--------------	--------------	--------------	--------------	--------------	--------------	--------------	--------------	--------------	--------------	--------------	--------------	--------------	--------------	--------------	--------------	--------------	--------------	--------------	--------------	--------------	--------------	--------------	--------------	--------------	--------------	--------------	--------------	--------------	--------------	--------------	--------------	--------------	--------------	--------------	--------------	--------------	--------------	--------------	--------------	--------------	--------------	--------------	--------------	--------------	--------------	--------------	--------------	--------------	--------------	--------------	--------------	--------------	--------------	--------------	--------------	--------------	--------------	--------------	--------------	--------------	--------------	--------------	--------------	--------------	--------------	--------------	--------------	--------------	--------------	--------------	--------------	--------------	--------------	--------------	--------------	--------------	--------------	--------------	--------------	--------------	--------------	--------------	--------------	--------------	--------------	--------------	--------------	--------------	--------------	--------------	--------------	--------------	--------------	--------------	--------------	--------------	--------------	--------------	--------------	--------------	--------------	--------------	--------------	--------------	--------------	--------------	--------------	--------------	--------------	--------------	--------------	--------------	--------------	--------------	--------------	--------------	--------------	--------------	--------------	--------------	--------------	--------------	--------------	--------------	--------------	--------------	--------------	--------------	--------------	--------------

Shim No.	New shim thickness	
	mm (in.)	Thickness
1	2.50 (0.0984)	10
2	2.55 (0.1004)	11
3	2.60 (0.1024)	12
4	2.65 (0.1043)	13
5	2.70 (0.1063)	14
6	2.75 (0.1083)	15
7	2.80 (0.1102)	16
8	2.85 (0.1122)	17
9	2.90 (0.1142)	17

**Intake valve clearance (Cold):**  
**0.19 - 0.29 mm (0.007 - 0.011 in.)**  
**EXAMPLE:** The 2.800 mm (0.1102 in.) shim is installed, and the measured clearance is 0.450 mm (0.0177 in.). Replace the 2.800 mm (0.1102 in.) shim with a No. 11 shim.



5S-FE ENGINE - ENGINE MECHANICAL

Adjusting Shim Selection Chart (Exhaust)

Measured clearance <sup>1</sup> mm (in.)	Installed shim thickness mm (in.)	Shim No.	Thickness	Shim No.	Thickness
0.000 - 0.020 (0.0000 - 0.0079)	1.1	1	1.1	1	1.1
0.021 - 0.040 (0.0083 - 0.0157)	1.1	1	1.1	1	1.1
0.041 - 0.060 (0.0161 - 0.0235)	1.1	1	1.1	1	1.1
0.061 - 0.080 (0.0239 - 0.0313)	1.1	1	1.1	1	1.1
0.081 - 0.100 (0.0317 - 0.0391)	1.1	1	1.1	1	1.1
0.101 - 0.120 (0.0400 - 0.0474)	1.1	1	1.1	1	1.1
0.121 - 0.140 (0.0478 - 0.0552)	1.1	1	1.1	1	1.1
0.141 - 0.160 (0.0556 - 0.0630)	1.1	1	1.1	1	1.1
0.161 - 0.180 (0.0634 - 0.0708)	1.1	1	1.1	1	1.1
0.181 - 0.200 (0.0712 - 0.0786)	1.1	1	1.1	1	1.1
0.201 - 0.220 (0.0790 - 0.0864)	1.1	1	1.1	1	1.1
0.221 - 0.240 (0.0868 - 0.0942)	1.1	1	1.1	1	1.1
0.241 - 0.260 (0.0946 - 0.1020)	1.1	1	1.1	1	1.1
0.261 - 0.280 (0.1024 - 0.1098)	1.1	1	1.1	1	1.1
0.281 - 0.300 (0.1102 - 0.1176)	1.1	1	1.1	1	1.1
0.301 - 0.320 (0.1180 - 0.1254)	1.1	1	1.1	1	1.1
0.321 - 0.340 (0.1258 - 0.1332)	1.1	1	1.1	1	1.1
0.341 - 0.360 (0.1336 - 0.1410)	1.1	1	1.1	1	1.1
0.361 - 0.380 (0.1414 - 0.1488)	1.1	1	1.1	1	1.1
0.381 - 0.400 (0.1512 - 0.1586)	1.1	1	1.1	1	1.1
0.401 - 0.420 (0.1610 - 0.1684)	1.1	1	1.1	1	1.1
0.421 - 0.440 (0.1708 - 0.1782)	1.1	1	1.1	1	1.1
0.441 - 0.460 (0.1806 - 0.1880)	1.1	1	1.1	1	1.1
0.461 - 0.480 (0.1904 - 0.1978)	1.1	1	1.1	1	1.1
0.481 - 0.500 (0.2002 - 0.2076)	1.1	1	1.1	1	1.1
0.501 - 0.520 (0.2100 - 0.2174)	1.1	1	1.1	1	1.1
0.521 - 0.540 (0.2208 - 0.2282)	1.1	1	1.1	1	1.1
0.541 - 0.560 (0.2306 - 0.2380)	1.1	1	1.1	1	1.1
0.561 - 0.580 (0.2404 - 0.2478)	1.1	1	1.1	1	1.1
0.581 - 0.600 (0.2502 - 0.2576)	1.1	1	1.1	1	1.1
0.601 - 0.620 (0.2600 - 0.2674)	1.1	1	1.1	1	1.1
0.621 - 0.640 (0.2708 - 0.2782)	1.1	1	1.1	1	1.1
0.641 - 0.660 (0.2806 - 0.2880)	1.1	1	1.1	1	1.1
0.661 - 0.680 (0.2904 - 0.2978)	1.1	1	1.1	1	1.1
0.681 - 0.700 (0.3002 - 0.3076)	1.1	1	1.1	1	1.1
0.701 - 0.720 (0.3100 - 0.3174)	1.1	1	1.1	1	1.1
0.721 - 0.740 (0.3208 - 0.3282)	1.1	1	1.1	1	1.1
0.741 - 0.760 (0.3306 - 0.3380)	1.1	1	1.1	1	1.1
0.761 - 0.780 (0.3404 - 0.3478)	1.1	1	1.1	1	1.1
0.781 - 0.800 (0.3502 - 0.3576)	1.1	1	1.1	1	1.1
0.801 - 0.820 (0.3600 - 0.3674)	1.1	1	1.1	1	1.1
0.821 - 0.840 (0.3708 - 0.3782)	1.1	1	1.1	1	1.1
0.841 - 0.860 (0.3806 - 0.3880)	1.1	1	1.1	1	1.1
0.861 - 0.880 (0.3904 - 0.3978)	1.1	1	1.1	1	1.1
0.881 - 0.900 (0.4002 - 0.4076)	1.1	1	1.1	1	1.1
0.901 - 0.920 (0.4100 - 0.4174)	1.1	1	1.1	1	1.1
0.921 - 0.940 (0.4208 - 0.4282)	1.1	1	1.1	1	1.1
0.941 - 0.960 (0.4306 - 0.4380)	1.1	1	1.1	1	1.1
0.961 - 0.980 (0.4404 - 0.4478)	1.1	1	1.1	1	1.1
0.981 - 1.000 (0.4502 - 0.4576)	1.1	1	1.1	1	1.1
1.001 - 1.020 (0.4600 - 0.4674)	1.1	1	1.1	1	1.1
1.021 - 1.040 (0.4708 - 0.4782)	1.1	1	1.1	1	1.1
1.041 - 1.060 (0.4806 - 0.4880)	1.1	1	1.1	1	1.1
1.061 - 1.080 (0.4904 - 0.4978)	1.1	1	1.1	1	1.1
1.081 - 1.100 (0.5002 - 0.5076)	1.1	1	1.1	1	1.1
1.101 - 1.120 (0.5100 - 0.5174)	1.1	1	1.1	1	1.1
1.121 - 1.140 (0.5208 - 0.5282)	1.1	1	1.1	1	1.1
1.141 - 1.160 (0.5306 - 0.5380)	1.1	1	1.1	1	1.1
1.161 - 1.180 (0.5404 - 0.5478)	1.1	1	1.1	1	1.1
1.181 - 1.200 (0.5502 - 0.5576)	1.1	1	1.1	1	1.1
1.201 - 1.220 (0.5600 - 0.5674)	1.1	1	1.1	1	1.1
1.221 - 1.240 (0.5708 - 0.5782)	1.1	1	1.1	1	1.1
1.241 - 1.260 (0.5806 - 0.5880)	1.1	1	1.1	1	1.1
1.261 - 1.280 (0.5904 - 0.5978)	1.1	1	1.1	1	1.1
1.281 - 1.300 (0.6002 - 0.6076)	1.1	1	1.1	1	1.1
1.301 - 1.320 (0.6100 - 0.6174)	1.1	1	1.1	1	1.1
1.321 - 1.340 (0.6208 - 0.6282)	1.1	1	1.1	1	1.1
1.341 - 1.360 (0.6306 - 0.6380)	1.1	1	1.1	1	1.1
1.361 - 1.380 (0.6404 - 0.6478)	1.1	1	1.1	1	1.1
1.381 - 1.400 (0.6502 - 0.6576)	1.1	1	1.1	1	1.1
1.401 - 1.420 (0.6600 - 0.6674)	1.1	1	1.1	1	1.1
1.421 - 1.440 (0.6708 - 0.6782)	1.1	1	1.1	1	1.1
1.441 - 1.460 (0.6806 - 0.6880)	1.1	1	1.1	1	1.1
1.461 - 1.480 (0.6904 - 0.6978)	1.1	1	1.1	1	1.1
1.481 - 1.500 (0.7002 - 0.7076)	1.1	1	1.1	1	1.1
1.501 - 1.520 (0.7100 - 0.7174)	1.1	1	1.1	1	1.1
1.521 - 1.540 (0.7208 - 0.7282)	1.1	1	1.1	1	1.1
1.541 - 1.560 (0.7306 - 0.7380)	1.1	1	1.1	1	1.1
1.561 - 1.580 (0.7404 - 0.7478)	1.1	1	1.1	1	1.1
1.581 - 1.600 (0.7502 - 0.7576)	1.1	1	1.1	1	1.1
1.601 - 1.620 (0.7600 - 0.7674)	1.1	1	1.1	1	1.1
1.621 - 1.640 (0.7708 - 0.7782)	1.1	1	1.1	1	1.1
1.641 - 1.660 (0.7806 - 0.7880)	1.1	1	1.1	1	1.1
1.661 - 1.680 (0.7904 - 0.7978)	1.1	1	1.1	1	1.1
1.681 - 1.700 (0.8002 - 0.8076)	1.1	1	1.1	1	1.1
1.701 - 1.720 (0.8100 - 0.8174)	1.1	1	1.1	1	1.1
1.721 - 1.740 (0.8208 - 0.8282)	1.1	1	1.1	1	1.1
1.741 - 1.760 (0.8306 - 0.8380)	1.1	1	1.1	1	1.1
1.761 - 1.780 (0.8404 - 0.8478)	1.1	1	1.1	1	1.1
1.781 - 1.800 (0.8502 - 0.8576)	1.1	1	1.1	1	1.1
1.801 - 1.820 (0.8600 - 0.8674)	1.1	1	1.1	1	1.1
1.821 - 1.840 (0.8708 - 0.8782)	1.1	1	1.1	1	1.1
1.841 - 1.860 (0.8806 - 0.8880)	1.1	1	1.1	1	1.1
1.861 - 1.880 (0.8904 - 0.8978)	1.1	1	1.1	1	1.1
1.881 - 1.900 (0.9002 - 0.9076)	1.1	1	1.1	1	1.1
1.901 - 1.920 (0.9100 - 0.9174)	1.1	1	1.1	1	1.1
1.921 - 1.940 (0.9208 - 0.9282)	1.1	1	1.1	1	1.1
1.941 - 1.960 (0.9306 - 0.9380)	1.1	1	1.1	1	1.1
1.961 - 1.980 (0.9404 - 0.9478)	1.1	1	1.1	1	1.1
1.981 - 2.000 (0.9502 - 0.9576)	1.1	1	1.1	1	1.1
2.001 - 2.020 (0.9600 - 0.9674)	1.1	1	1.1	1	1.1
2.021 - 2.040 (0.9708 - 0.9782)	1.1	1	1.1	1	1.1
2.041 - 2.060 (0.9806 - 0.9880)	1.1	1	1.1	1	1.1
2.061 - 2.080 (0.9904 - 0.9978)	1.1	1	1.1	1	1.1
2.081 - 2.100 (1.0002 - 1.0076)	1.1	1	1.1	1	1.1
2.101 - 2.120 (1.0100 - 1.0174)	1.1	1	1.1	1	1.1
2.121 - 2.140 (1.0208 - 1.0282)	1.1	1	1.1	1	1.1
2.141 - 2.160 (1.0306 - 1.0380)	1.1	1	1.1	1	1.1
2.161 - 2.180 (1.0404 - 1.0478)	1.1	1	1.1	1	1.1
2.181 - 2.200 (1.0502 - 1.0576)	1.1	1	1.1	1	1.1
2.201 - 2.220 (1.0600 - 1.0674)	1.1	1	1.1	1	1.1
2.221 - 2.240 (1.0708 - 1.0782)	1.1	1	1.1	1	1.1
2.241 - 2.260 (1.0806 - 1.0880)	1.1	1	1.1	1	1.1
2.261 - 2.280 (1.0904 - 1.0978)	1.1	1	1.1	1	1.1
2.281 - 2.300 (1.1002 - 1.1076)	1.1	1	1.1	1	1.1
2.301 - 2.320 (1.1100 - 1.1174)	1.1	1	1.1	1	1.1
2.321 - 2.340 (1.1208 - 1.1282)	1.1	1	1.1	1	1.1
2.341 - 2.360 (1.1306 - 1.1380)	1.1	1	1.1	1	1.1
2.361 - 2.380 (1.1404 - 1.1478)	1.1	1	1.1	1	1.1
2.381 - 2.400 (1.1502 - 1.1576)	1.1	1	1.1	1	1.1
2.401 - 2.420 (1.1600 - 1.1674)	1.1	1	1.1	1	1.1
2.421 - 2.440 (1.1708 - 1.1782)	1.1	1	1.1	1	1.1
2.441 - 2.460 (1.1806 - 1.1880)	1.1	1	1.1	1	1.1
2.461 - 2.480 (1.1904 - 1.1978)	1.1	1	1.1	1	1.1
2.481 - 2.500 (1.2002 - 1.2076)	1.1	1	1.1	1	1.1
2.501 - 2.520 (1.2100 - 1.2174)	1.1	1	1.1	1	1.1
2.521 - 2.540 (1.2208 - 1.2282)	1.1	1	1.1	1	1.1
2.541 - 2.560 (1.2306 - 1.2380)	1.1	1	1.1	1	1.1
2.561 - 2.580 (1.2404 - 1.2478)	1.1	1	1.1	1	1.1
2.581 - 2.600 (1.2502 - 1.2576)	1.1	1	1.1	1	1.1
2.601 - 2.620 (1.2600 - 1.2674)	1.1	1	1.1	1	1.1
2.621 - 2.640 (1.2708 - 1.2782)	1.1	1	1.1	1	1.1
2.641 - 2.660 (1.2806 - 1.2880)	1.1	1	1.1	1	1.1
2.661 - 2.680 (1.2904 - 1.2978)	1.1	1	1.1	1	1.1
2.681 - 2.700 (1.3002 - 1.3076)	1.1	1	1.1	1	1.1
2.701 - 2.720 (1.3100 - 1.3174)	1.1	1	1.1	1	1.1
2.721 - 2.740 (1.3208 - 1.3282)	1.1	1	1.1	1	1.1
2.741 - 2.760 (1.3306 - 1.3380)	1.1	1	1.1	1	1.1
2.761 - 2.780 (1.3404 - 1.3478)	1.1	1	1.1	1	1.1
2.781 - 2.800 (1.3502 - 1.3576)	1.1	1	1.1	1	1.1
2.801 - 2.820 (1.3600 - 1.3674)	1.1	1	1.1	1	1.1
2.821 - 2.840 (1.3708 - 1.3782)	1.1	1	1.1	1	1.1
2.841 - 2.860 (1.3806 - 1.3880)	1.1	1	1.1	1	1.1
2.861 - 2.880 (1.3904 - 1.3978)	1.1	1	1.1	1	1.1
2.881 - 2.900 (1.4002 - 1.4076)	1.1	1	1.1	1	1.1
2.901 - 2.920 (1.4100 - 1.4174)	1.1	1	1.1	1	1.1
2.921 - 2.940 (1.4208 - 1.4282)	1.1	1	1.1	1	1.1
2.941 - 2.960 (1.4306 - 1.4380)	1.1	1	1.1	1	1.1
2.961 - 2.980 (1.4404 - 1.4478)	1.1	1	1.1	1	1.1
2.981 - 3.000 (1.4502 - 1.4576)	1.1	1	1.1	1	1.1
3.001 - 3.020 (1.4600 - 1.4674)	1.1	1	1.1	1	1.1
3.021 - 3.040 (1.4708 - 1.4782)	1.1	1	1.1	1	1.1
3.041 - 3.060 (1.4806 - 1.4880)	1.1	1	1.1	1	1.1
3.061 - 3.080 (1.4904 - 1.4978)	1.1	1	1.1	1	1.1
3.081 - 3.100 (1.5002 - 1.5076)	1.1	1	1.1	1	1.1
3.101 - 3.120 (1.5100 - 1.5174)	1.1	1	1.1	1	1.1
3.121 - 3.140 (1.5208 - 1.5282)	1.1	1	1.1	1	1.1
3.141 - 3.160 (1.5306 - 1.5380)	1.1	1	1.1	1	1.1
3.161 - 3.180 (1.5404 - 1.5478)	1.1	1	1.1	1	1.1
3.181 - 3.200 (1.5502 - 1.5576)	1.1	1	1.1	1	1.1
3.201 - 3.220 (1.5600 - 1.5674)	1.1	1	1.1	1	1.1
3.221 - 3.240 (1.5708 - 1.5782)	1.1	1	1.1	1	1.1
3.241 - 3.260 (1.5806 - 1.5880)	1.1	1	1.1	1	1.1
3.261 - 3.280 (1.5904 - 1.5978)	1.1	1	1.1	1	1.1
3.281 - 3.300 (1.6002 - 1.6076)	1.1	1	1.1		

## EG1-18

5S-FE ENGINE – ENGINE MECHANICAL

## IGNITION TIMING INSPECTION AND ADJUSTMENT

### 1. WARM UP ENGINE

Allow the engine to warm up to normal operating temperature.

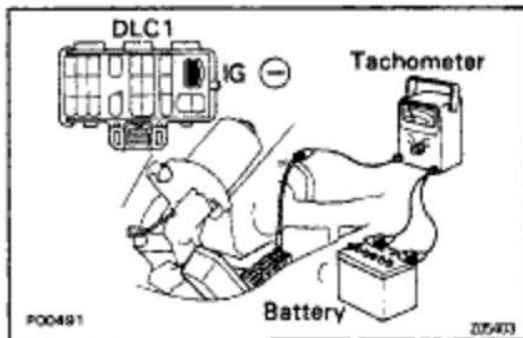

### 2. CONNECT TACHOMETER AND TIMING LIGHT TO ENGINE

Connect the test probe of a tachometer to terminal IG (-) of the data link connector 1.

#### NOTICE:

- **NEVER** allow the tachometer terminal to touch ground as it could result in damage to the igniter and/or ignition coil.
- As some tachometers are not compatible with this ignition system, we recommend that you confirm the compatibility of yours before use.

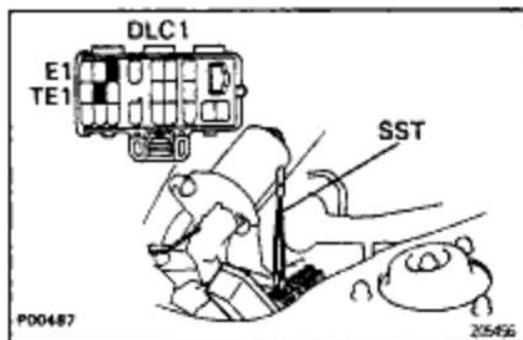

### 3. ADJUST IGNITION TIMING

(a) Using SST, connect terminals TE1 and E1 of the data link connector 1.

SST 09843-18020

HINT: After engine speed is kept at 1,000 – 1,300 rpm for 5 seconds, check that it returns to idle speed.

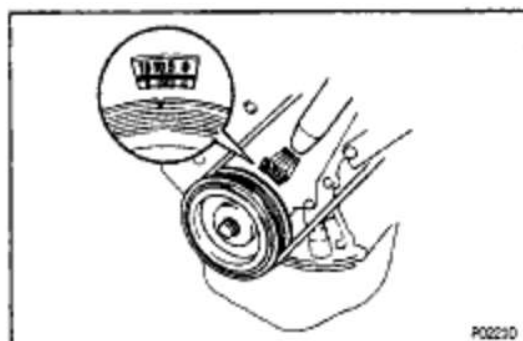

(b) Using a timing light, check the ignition timing.

**Ignition timing:**

**10° BTDC @ idle**

**(Transmission in neutral position)**

## 5S-FE ENGINE - ENGINE MECHANICAL

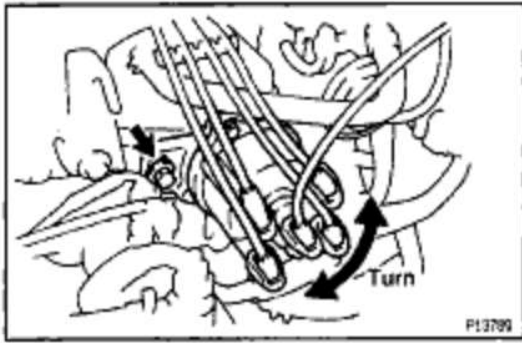

- (c) Loosen the bolt (California) or 2 bolts (except California), and adjust by turning the distributor.
- (d) Tighten the bolt (California) or 2 bolts (except California), and recheck the ignition timing.

**Torque: 19 N-m (195 kgf-cm, 14 ft-lbf)**

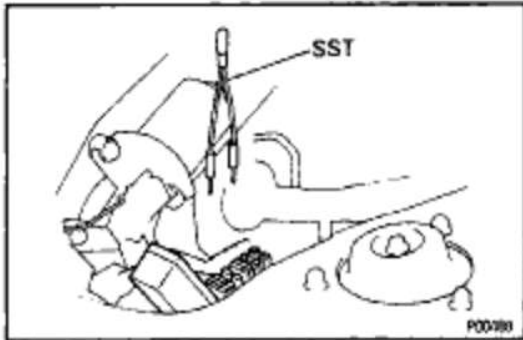

- (e) Remove the SST.  
SST 09843-18020

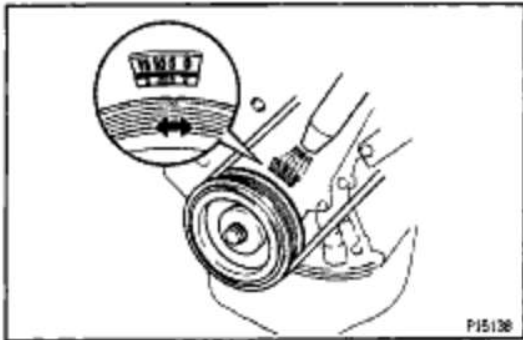

#### 4. FURTHER CHECK IGNITION TIMING

Ignition timing:

**0 - 10° BTDC @ idle**

**(Transmission in neutral position)**

HINT: The timing mark moves in a range between 0° and 10°.

#### 5. DISCONNECT TACHOMETER AND TIMING LIGHT FROM ENGINE

## EG1-20

5S-FE ENGINE - ENGINE MECHANICAL

**IDLE SPEED INSPECTION**

MECH-01

**1. INITIAL CONDITIONS**

- (a) Engine at normal operating temperature
- (b) Air cleaner installed
- (c) All pipes and hoses of air induction system connected
- (d) All vacuum lines properly connected
  - (e) MFI/SFI system wiring connectors fully plugged
- (f) All operating accessories switched OFF
- (g) Ignition timing set correctly
- (h) Transmission in neutral position

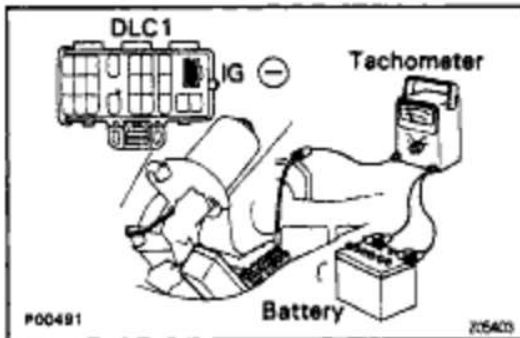
**2. CONNECT TACHOMETER**

Connect the test probe of a tachometer to terminal IG (-) of the data link connector 1.

**NOTICE:**

- Never allow the tachometer terminal to touch ground as it could result in damage to the Igniter and/or ignition coil.
- As some tachometers are not compatible with this ignition system, we recommend that you confirm the compatibility of yours before use.

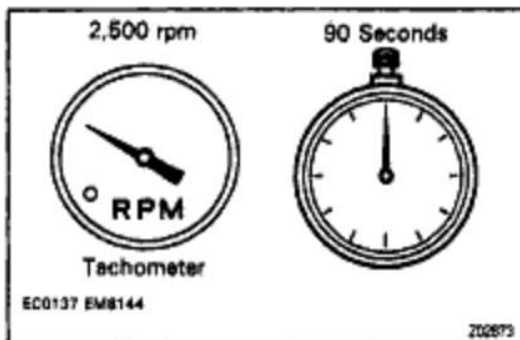
**3. INSPECT IDLE SPEED**

- (a) Race the engine at 2,500 rpm for approx. 90 seconds.

- (b) Check the idle speed.

**Idle speed (w/ Cooling fan OFF):**

**750±50 rpm**

If the idle speed is not as specified, check the IAC system.

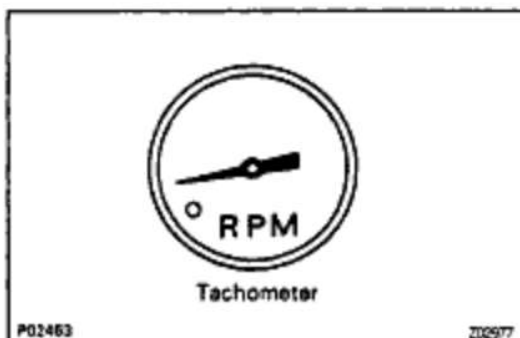
**4. DISCONNECT TACHOMETER**

## IDLE AND OR 2,500 RPM CO/HC CHECK

HINT: This check is used only to determine whether or not the idle CO/HC complies with regulations.

### 1. INITIAL CONDITIONS

- (a) Engine at normal operating temperature
- (b) Air cleaner installed
- (c) All pipes and hoses of air induction system connected
- (d) All accessories switched OFF
- (e) All vacuum lines properly connected

HINT: All vacuum hoses for EGR systems, etc. should be properly connected.

- (f) MFI/SFI system wiring connectors fully plugged
- (g) Ignition timing set correctly
- (h) Transmission in neutral position
- (i) Tachometer and CO/HC meter calibrated by hand.

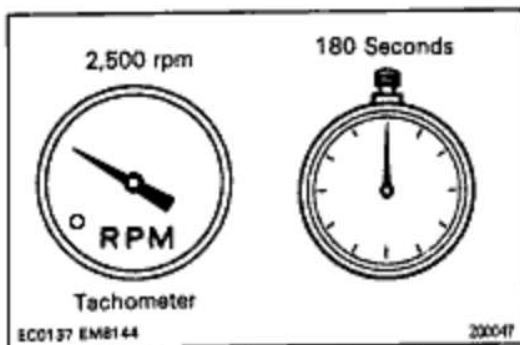

### 2. START ENGINE

### 3. RACE ENGINE AT 2,500 RPM FOR APPROX. 180 SECONDS

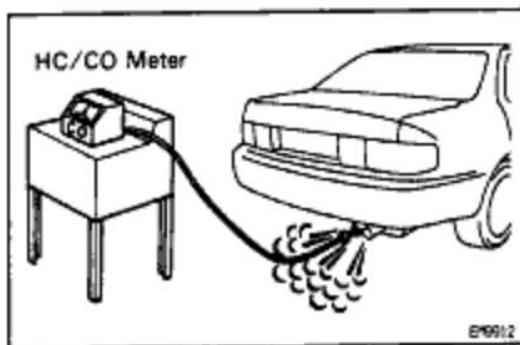

### 4. INSERT CO/HC METER TESTING PROBE AT LEAST 40 cm (1.3 ft) INTO TAILPIPE DURING IDLING

### 5. IMMEDIATELY CHECK CO/HC CONCENTRATION AT IDLE AND/OR 2,500 RPM

Complete the measuring within 3 minutes.

HINT: When performing the 2 mode (2,500 rpm and idle) test, follow the measurement order prescribed by the applicable local regulations.

## EG1-22

## 5S-FE ENGINE – ENGINE MECHANICAL

**Troubleshooting**

If the CO/HC concentration does not comply with regulations, perform troubleshooting in the order given below.

- (a) Check oxygen sensor operation.  
(See page EG1-231)
- (b) See the table below for possible causes, then inspect and correct the applicable causes if necessary.

HC	CO	Problems	Causes
High	Normal	Rough idle	<ol style="list-style-type: none"> <li>1. Faulty ignitions: <ul style="list-style-type: none"> <li>• Incorrect timing</li> <li>• Fouled, shorted or improperly gapped plugs</li> <li>• Open or crossed high-tension cords</li> <li>• Cracked distributor cap</li> </ul> </li> <li>2. Incorrect valve clearance</li> <li>3. Leaky EGR valve</li> <li>4. Leaky intake and exhaust valves</li> <li>5. Leaky cylinder</li> </ol>
High	Low	Rough idle (Fluctuating HC reading)	<ol style="list-style-type: none"> <li>1. Vacuum leaks: <ul style="list-style-type: none"> <li>• PCV hose</li> <li>• EGR valve</li> <li>• Intake manifold</li> <li>• Throttle body</li> <li>• IAC valve</li> <li>• Brake booster line</li> </ul> </li> <li>2. Lean mixture causing misfire</li> </ol>
High	High	Rough idle (Black smoke from exhaust)	<ol style="list-style-type: none"> <li>1. Restricted air filter</li> <li>2. Faulty MFI/SFI systems <ul style="list-style-type: none"> <li>• Faulty pressure regulator</li> <li>• Clogged fuel return line</li> <li>• Defective engine coolant temp. sensor</li> <li>• Defective intake air temp. sensor</li> </ul> </li> <li>3. Faulty ECM</li> <li>4. Faulty injector</li> <li>5. Faulty throttle position sensor</li> <li>6. MAP sensor</li> </ol>

V0665

## COMPRESSION CHECK

HINT: If there is lack of power, excessive oil consumption or poor fuel economy, measure the compression pressure.

### 1. WARM UP AND STOP ENGINE

Allow the engine to warm up to normal operating temperature.

### 2. DISCONNECT DISTRIBUTOR CONNECTOR(S)

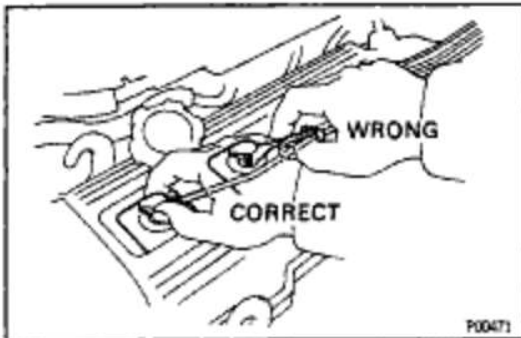

### 3. DISCONNECT HIGH – TENSION CORDS FROM SPARK PLUGS

Disconnect the high – tension cords at the rubber boot.

DO NOT pull on the cords.

**NOTICE:** Pulling on or bending the cords may damage the conductor inside.

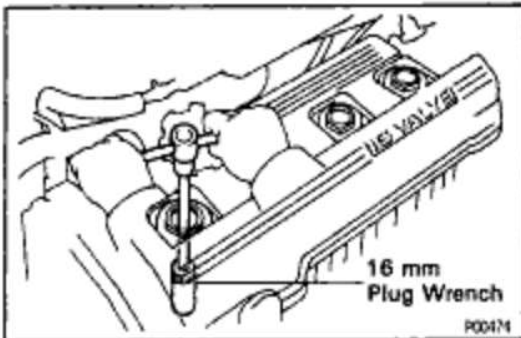

### 4. REMOVE SPARK PLUGS

Using a 16 mm plug wrench, remove the spark plug.

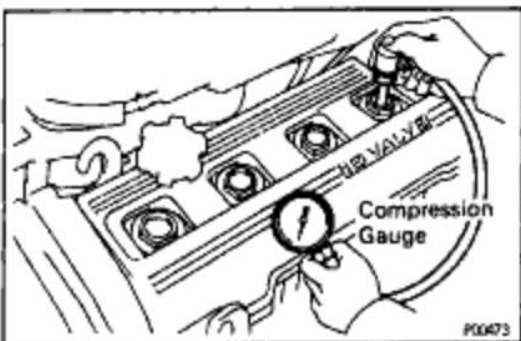

### 5. CHECK CYLINDER COMPRESSION PRESSURE

- (a) Insert a compression gauge into the spark plug hole.
- (b) Fully open the throttle.
- (c) While cranking the engine, measure the compression pressure.

HINT: Always use a fully charged battery to obtain engine speed of 250 rpm or more.

- (d) Repeat steps (a) through (c) for each cylinder.

**NOTICE:** This measurement must be done in as short a time as possible.

Compression pressure:

**1,226 kPa (12.5 kgf/cm<sup>2</sup>, 178 psi) or more**

Minimum pressure:

**981 kPa (10.0 kgf/cm<sup>2</sup>, 142 psi)**

Difference between each cylinder:

**98 kPa (1.0 kgf/cm<sup>2</sup>, 14 psi) or less**

**EG1-24****5S-FE ENGINE – ENGINE MECHANICAL**

- (e) If the cylinder compression in one or more cylinders is low, pour a small amount of engine oil into the cylinder through the spark plug hole and repeat steps (a) through (c) for cylinders with low compression.
- If adding oil helps the compression, chances are that the piston rings and/or cylinder bore are worn or damaged.
  - If pressure stays low, a valve may be sticking or seating is improper, or there may be leakage past the gasket.

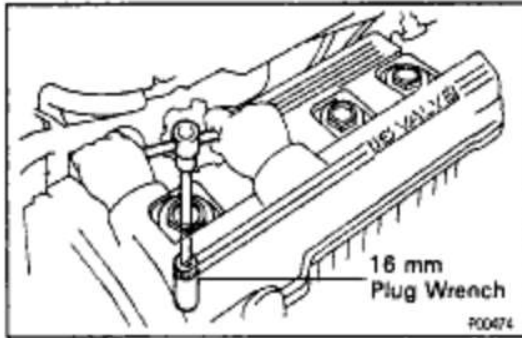
**6. REINSTALL SPARK PLUGS**

Using a 16 mm plug wrench, install the spark plug.

**Torque: 18 N-m (180 kgf-cm, 13 ft-lbf)**

**7. RECONNECT HIGH-TENSION CORDS TO SPARK PLUGS****8. RECONNECT DISTRIBUTOR CONNECTOR(S)**



# TIMING BELT COMPONENTS FOR REMOVAL AND INSTALLATION

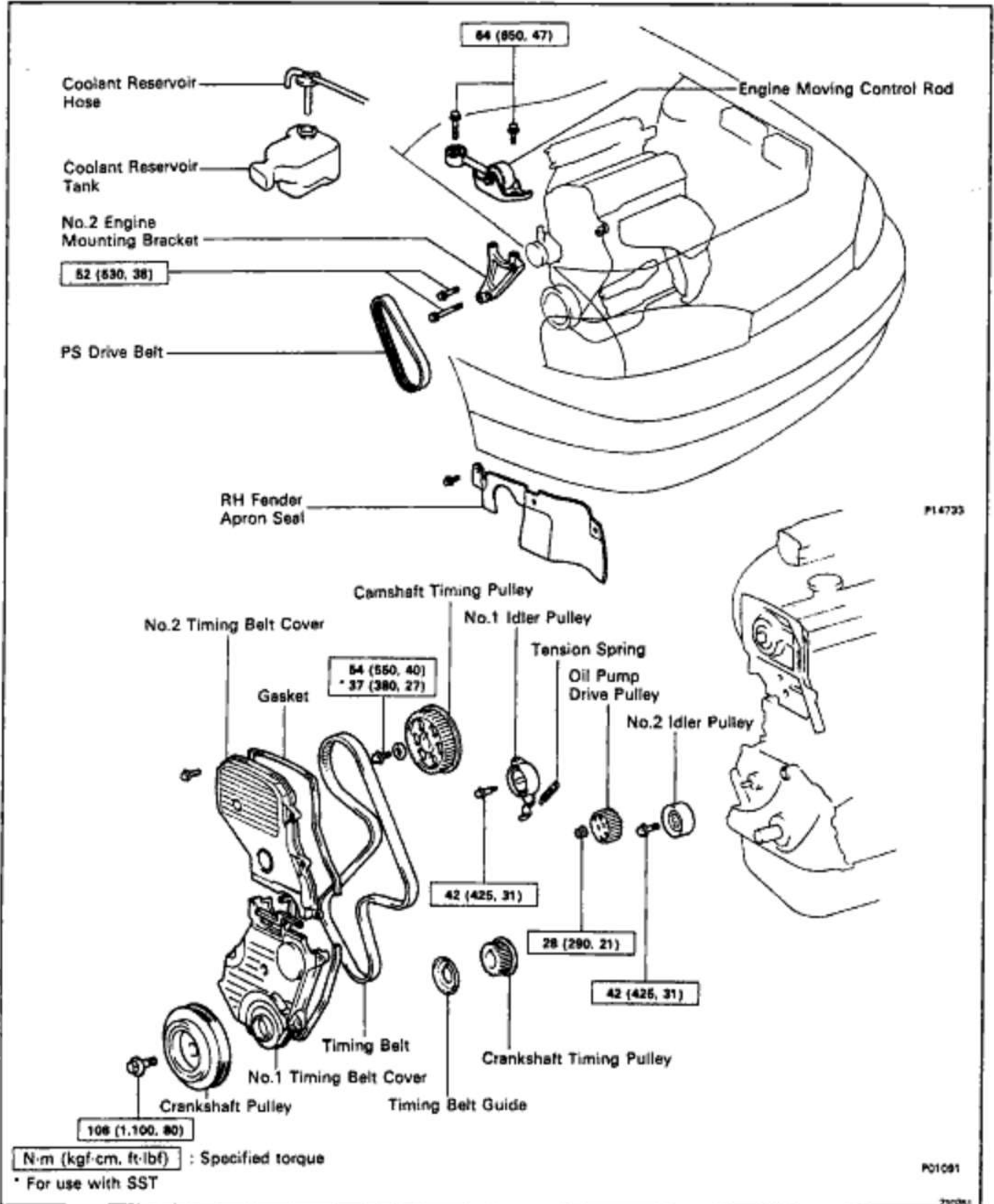

## EG1-26

## 5S-FE ENGINE - ENGINE MECHANICAL

MECH-41

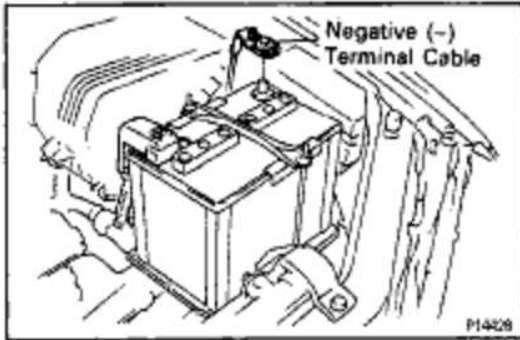
**TIMING BELT REMOVAL**

(See Components for Removal and Installation)

**1. DISCONNECT NEGATIVE (-) TERMINAL CABLE FROM BATTERY**

**CAUTION:** Work must be started after 90 seconds from the time the ignition switch is turned to the 'LOCK' position and the negative (-) terminal cable is disconnected from the battery.

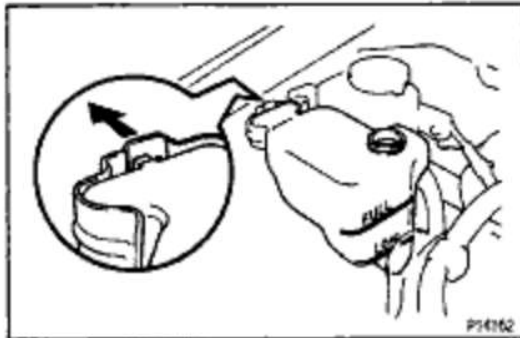
**2. REMOVE ENGINE COOLANT RESERVOIR TANK**

- (a) Disconnect the reservoir hose.
- (b) While pushing the tab of the bracket, remove the reservoir tank.

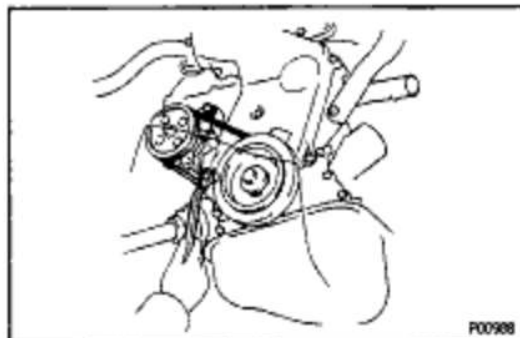
**3. REMOVE GENERATOR (See page CH-10)****4. REMOVE RH FRONT WHEEL****5. REMOVE RH FENDER APRON SEAL****6. REMOVE PS DRIVE BELT**

Loosen the 2 bolts, and remove the drive belt.

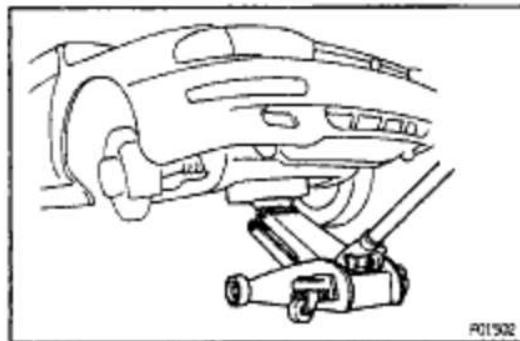
**7. SLIGHTLY JACK UP ENGINE**

Raise the engine enough to remove the weight from the engine mounting on the right side.

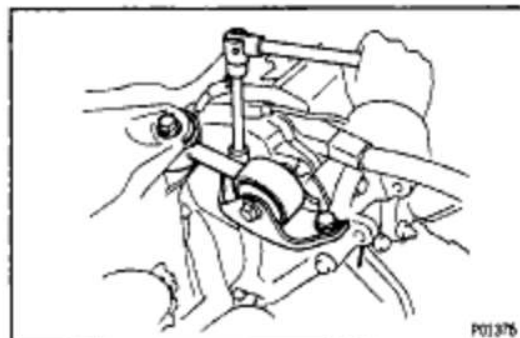
**8. REMOVE ENGINE MOVING CONTROL ROD**

Remove the 3 bolts and control rod.

**9. DISCONNECT CONNECTOR FROM GROUND WIRE ON RH FENDER APRON**

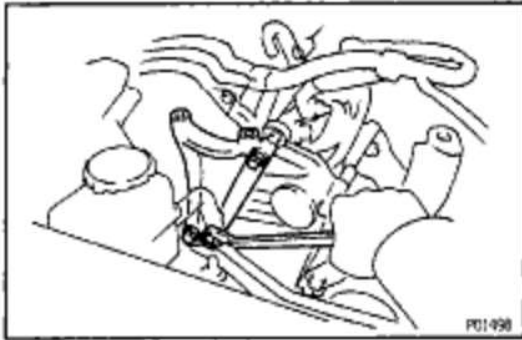
**10. REMOVE No.2 ENGINE MOUNTING BRACKET**

Remove the 3 bolts and mounting bracket.

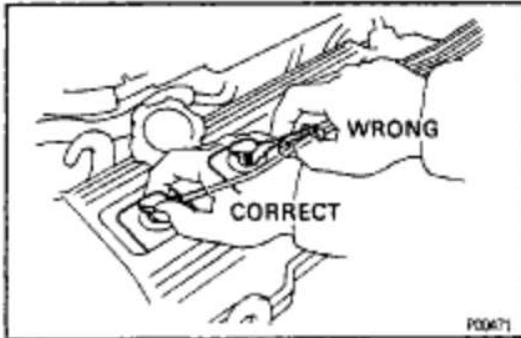
**11. REMOVE SPARK PLUGS**

(a) Disconnect the high – tension cords at the rubber boot.

DO NOT pull on the cords.

**NOTICE:** Pulling on or bending the cords may damage the conductor inside.

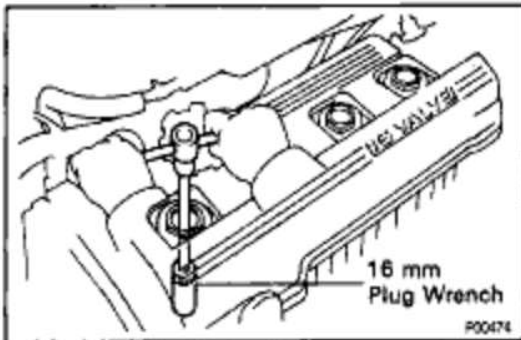

(b) Using a 16 mm plug wrench, remove the spark plug.

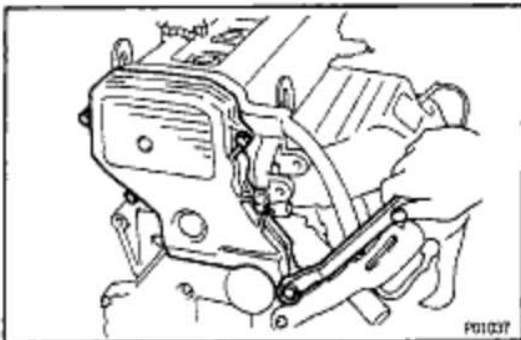
**12. REMOVE NO.2 TIMING BELT COVER**

Remove the 5 bolts, timing belt cover and 2 gaskets.

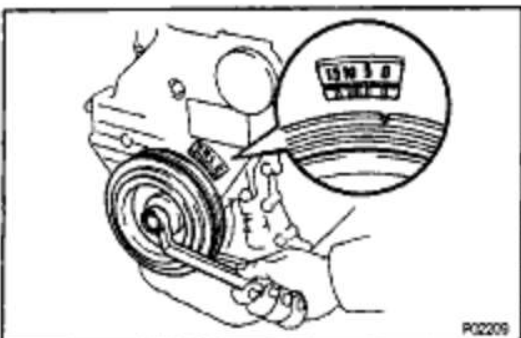
**13. SET NO.1 CYLINDER TO TDC/COMPRESSION**

(a) Turn the crankshaft pulley and align its groove with timing mark "0" of the No.1 timing belt cover.

## EG1-28

## 5S-FE ENGINE - ENGINE MECHANICAL

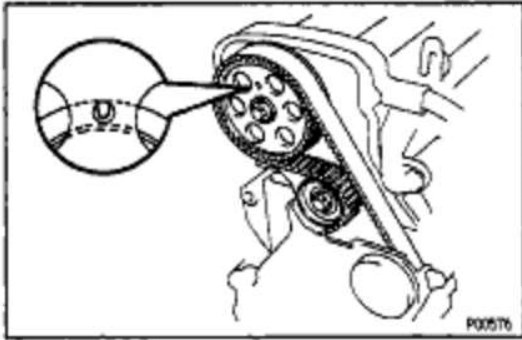

- (b) Check that the hole of the camshaft timing pulley is aligned with the timing mark of the bearing cap. If not, turn the crankshaft one revolution (360°\*).

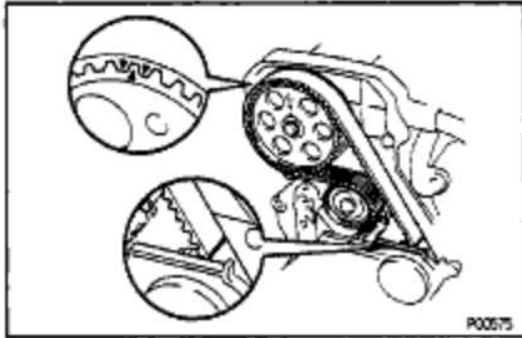

#### 14. REMOVE TIMING BELT FROM CAMSHAFT TIMING PULLEY

HINT (When re-using timing belt): Place the matchmarks on the timing belt and camshaft timing pulley, and place matchmark on timing belt to match the end of the No.1 timing belt cover.



- (a) Loosen the mounting bolt of the No.1 idler pulley and shift the pulley toward the left as far as it will go, and temporarily tighten it.

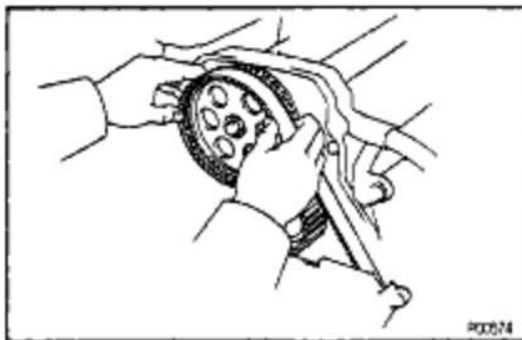

- (b) Remove the timing belt from the camshaft timing pulley.

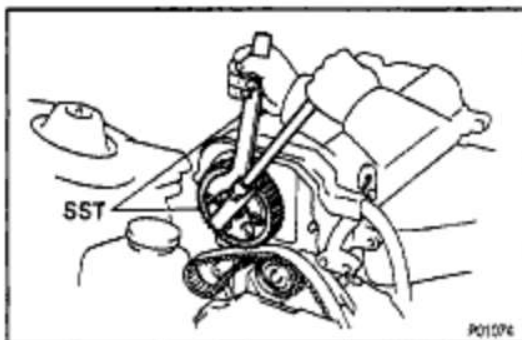

#### 15. REMOVE CAMSHAFT TIMING PULLEY

Using SST, remove the bolt, plate washer and timing pulley.

SST 09249-63010 and 09278-54012

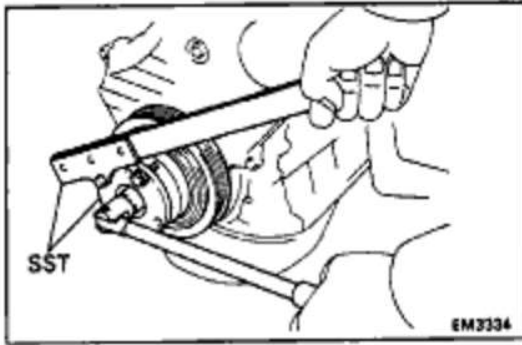

## 16. REMOVE CRANKSHAFT PULLEY

- (a) Using SST, remove the pulley bolt.  
SST 09213-54015 (91651-60855),  
09330-00021

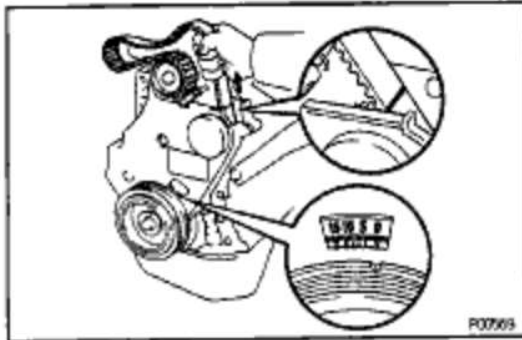

**HINT** (When re-using timing belt): After loosening the crankshaft pulley bolt, check that the timing belt matchmark aligns with the end of the No. 1 timing belt cover when the crankshaft pulley groove is aligned with the timing mark "0" of the No. 1 timing belt cover. If the matchmark does not align, align as follows:

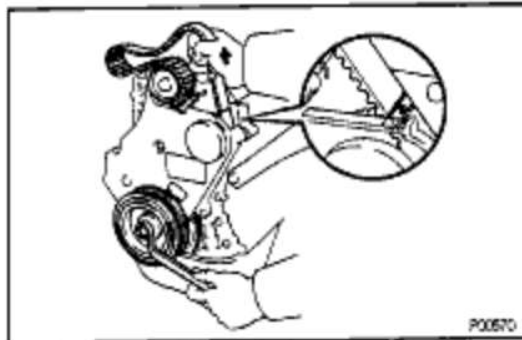

When matchmark is misaligned clockwise:

- Align the matchmark by pulling the timing belt up on the water pump pulley side while turning the crankshaft pulley counterclockwise.

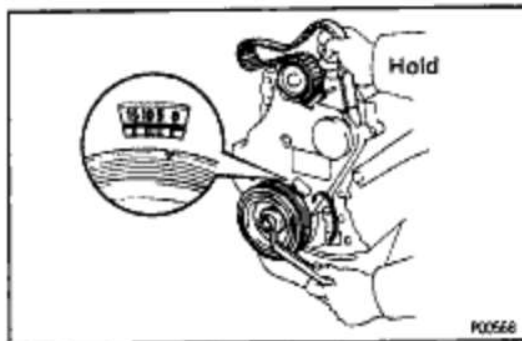

- After aligning the matchmark, hold the timing belt, turn the crankshaft pulley clockwise, and align its groove with timing mark "0" of the No. 1 timing belt cover.

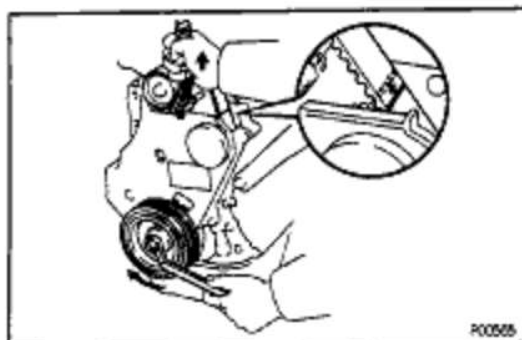

When matchmark is misaligned counterclockwise:

- Align the matchmarks by pulling the timing belt up on the No. 1 idler pulley side while turning the crankshaft pulley clockwise.

## EG1-30

## 5S-FE ENGINE - ENGINE MECHANICAL

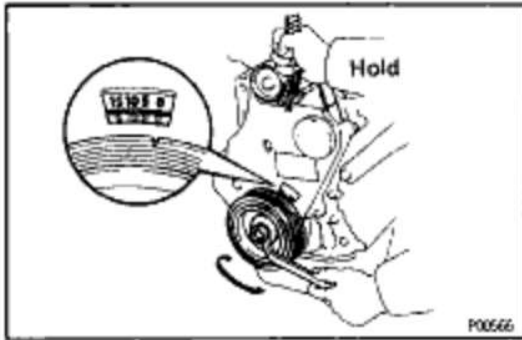

- After aligning the matchmark, hold the timing belt, turn the crankshaft pulley counterclockwise, and align its groove with timing mark "0" of the No.1 timing belt cover.

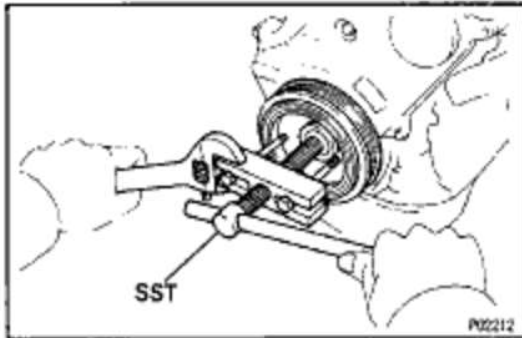

- (b) Using SST, remove the pulley.  
 SST 09213-60017 (09213-00020, 09213-00030, 09213-00060)  
 HINT (When re-using timing belt): Remove the pulley without turning it.

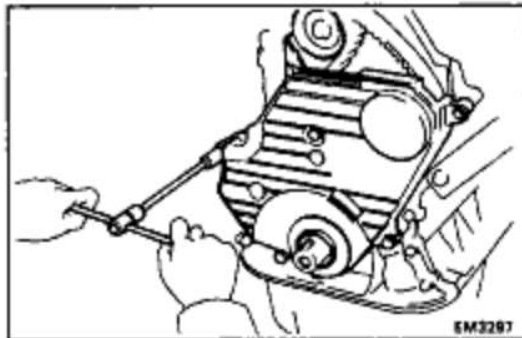
**17. REMOVE No.1 TIMING BELT COVER**

Remove the 4 bolts, timing belt cover and gasket.

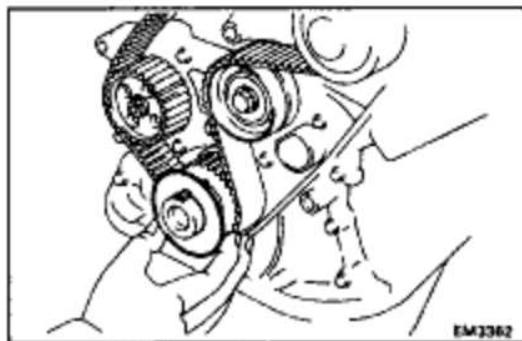
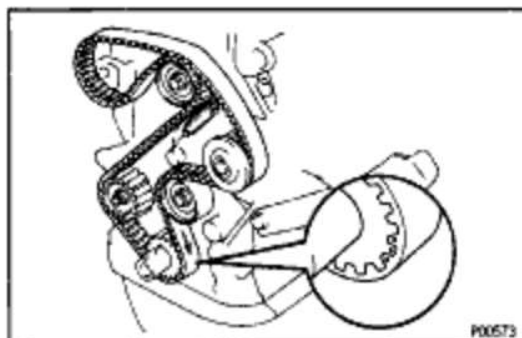
**18. REMOVE TIMING BELT GUIDE****19. REMOVE TIMING BELT**

HINT (When re-using timing belt): Draw a direction arrow on the timing belt (in the direction of engine revolution), and place matchmarks on the timing belt and crankshaft timing pulley.

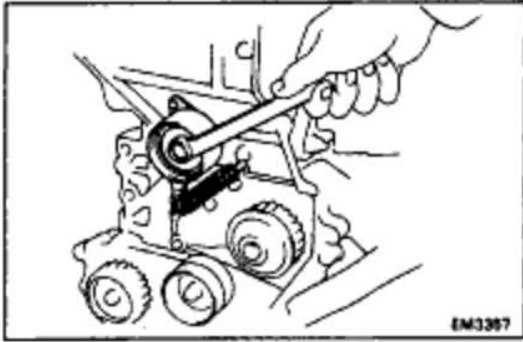

## 20. REMOVE NO.1 IDLER PULLEY AND TENSION SPRING

Remove the bolt, pulley and tension spring.

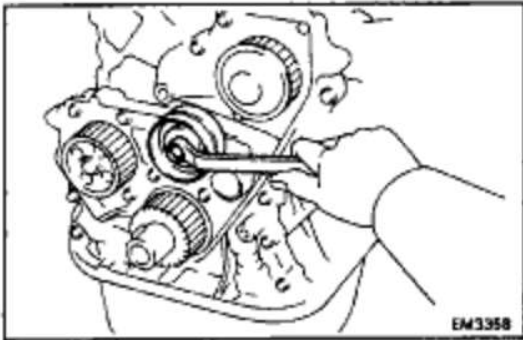

## 21. REMOVE NO.2 IDLER PULLEY

Remove the bolt and pulley.

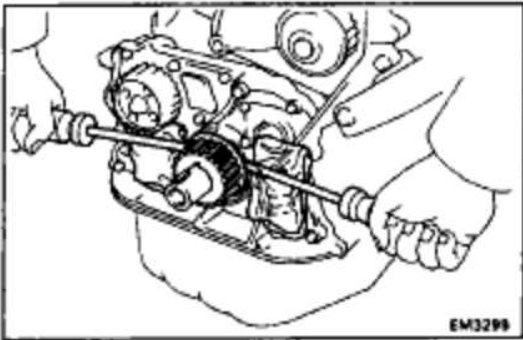

## 22. REMOVE CRANKSHAFT TIMING PULLEY

If the pulley cannot be removed by hand, use 2 screw-drivers.

HINT: Position shop rags as shown to prevent damage.

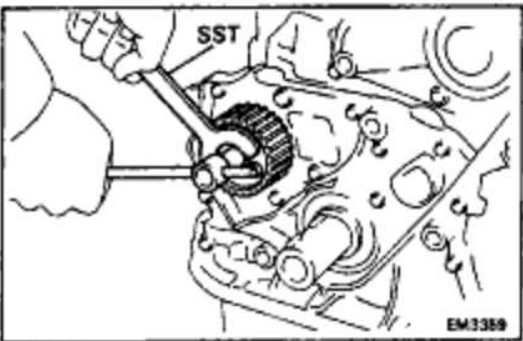

## 23. REMOVE OIL PUMP PULLEY

Using SST, remove the nut and pulley.

SST 09616-30011

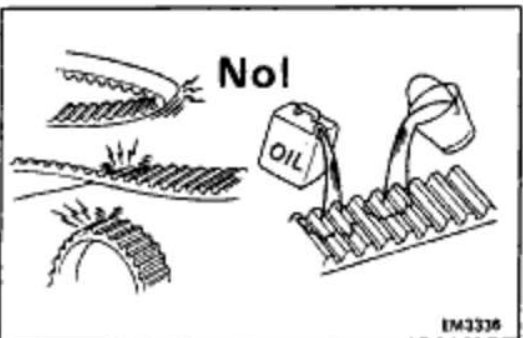

## TIMING BELT COMPONENTS INSPECTION

### 1. INSPECT TIMING BELT

#### NOTICE:

- Do not bend, twist or turn the timing belt inside out.
- Do not allow the timing belt to come into contact with oil, water or steam.

## EG1-32

## 5S-FE ENGINE – ENGINE MECHANICAL

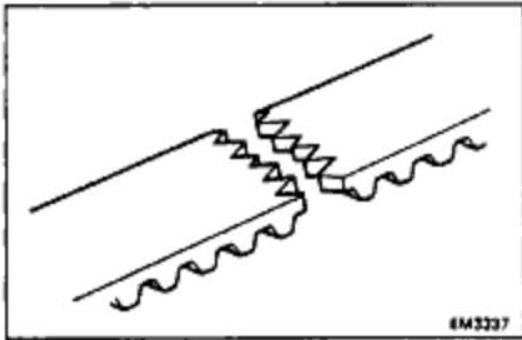

- **Do not utilize timing belt tension when installing or removing the mounting bolt of the camshaft timing pulley.**

If there are any defects as shown in the illustration, check the following points:

(a) Premature parting

- Check for proper installation.
- Check the timing cover gasket for damage and proper installation.

(b) If the belt teeth are cracked or damaged, check to see if either camshaft or water pump is locked.

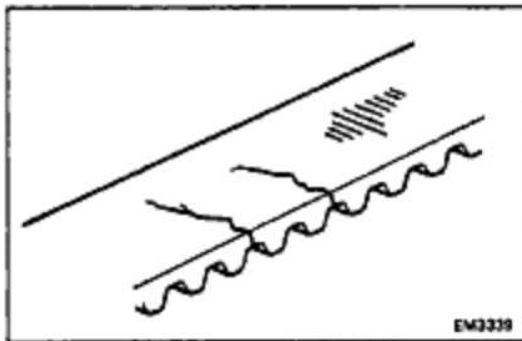
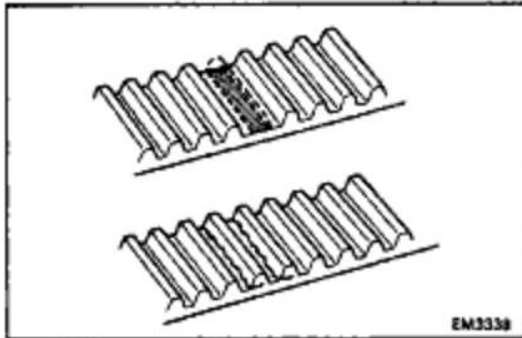

(c) If there is noticeable wear or cracks on the belt face, check to see if there are nicks on the side of the idler pulley lock.

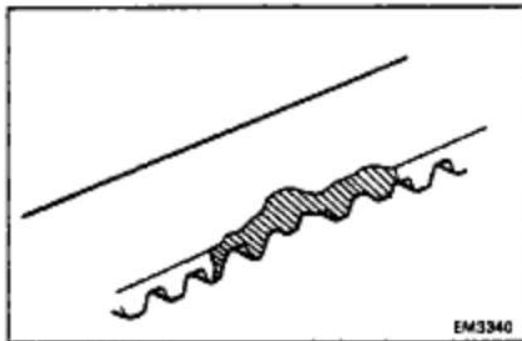

(d) If there is wear or damage on only one side of the belt, check the belt guide and the alignment of each pulley.

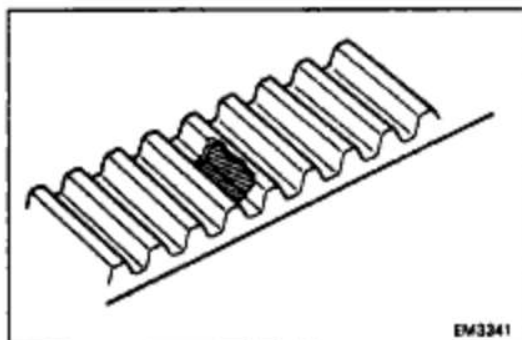

(e) If there is noticeable wear on the belt teeth, check the timing cover for damage, correct gasket installation, and for foreign material on the pulley teeth. If necessary, replace the timing belt.



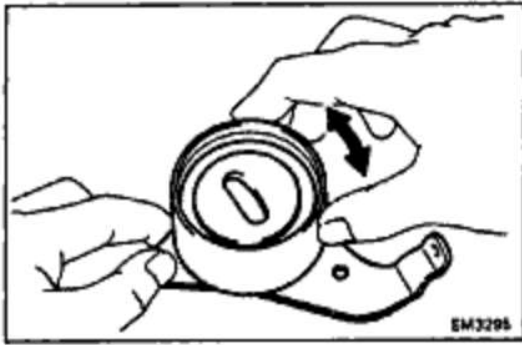

## 2. INSPECT IDLER PULLEYS

Check that the idler pulley turns smoothly.  
If necessary, replace the idler pulley.

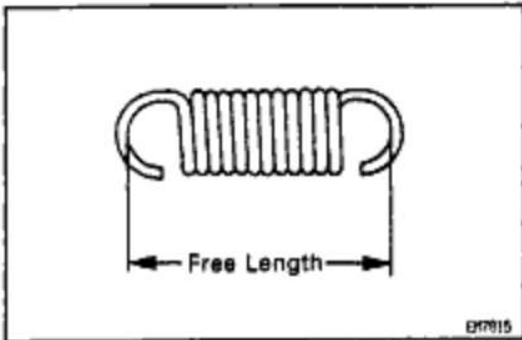

## 3. INSPECT TENSION SPRING

(a) Measure the free length of tension spring.

**Free length:**

**46.0 mm (1.811 in.)**

If the free length is not as specified, replace the tension spring.

(b) Measure the tension of the tension spring at the specified installed length.

**Installed tension (at 50.5 mm (1.988 in.):**

**Green color**

**32 – 37 N (3.25 – 3.75 kgf, 7.2 – 8.3 lbf)**

**Silver color**

**47 – 52 N (4.75 – 5.25 kgf, 10.5 – 11.8 lbf)**

If the installed tension is not as specified, replace the tension spring.

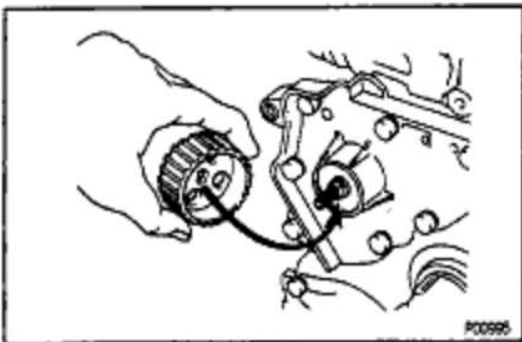

## TIMING BELT INSTALLATION

(See Components for Removal and Installation)

### 1. INSTALL OIL PUMP PULLEY

(a) Align the cutouts of the pulley and shaft, and slide on the pulley.

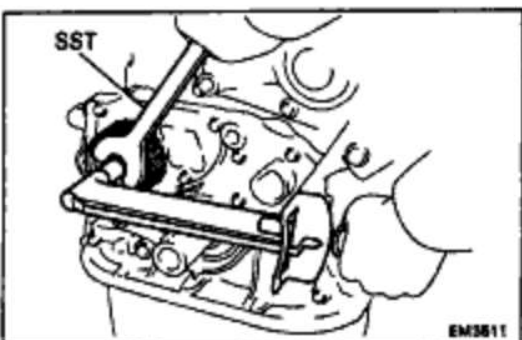

(b) Using SST, install the nut.

SST 09616 – 30011

**Torque: 28 N-m (290 kgf-cm, 21 ft-lbf)**

## EG1-34

## 5S-FE ENGINE - ENGINE MECHANICAL

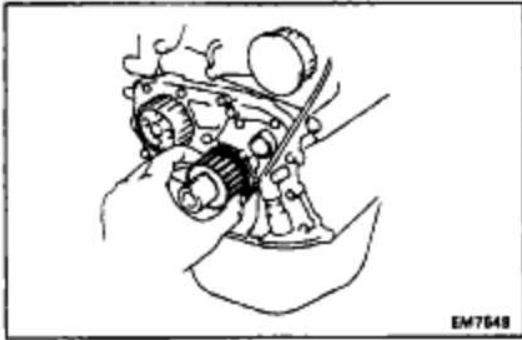
**2. INSTALL CRANKSHAFT TIMING PULLEY**

- (a) Align the timing pulley set key with the key groove of the pulley.
- (b) Slide on the timing pulley, facing the flange side inward.

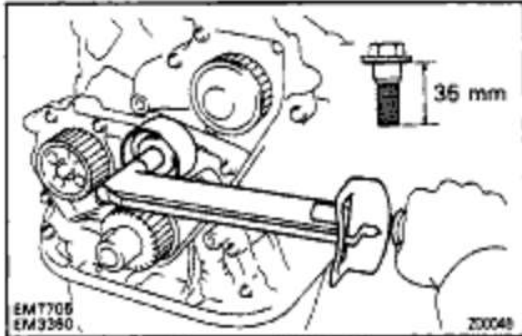
**3. INSTALL NO.2 IDLER PULLEY**

- (a) Install the pulley with the bolt.

**Torque: 42 N-m (425 kgf-cm, 31 ft-lbf)**

**HINT:** Use a bolt 35 mm (1.38 in.) in length.

- (b) Check that the idler pulley moves smoothly.

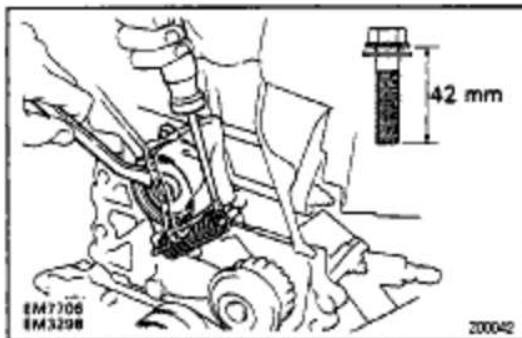
**4. TEMPORARILY INSTALL NO.1 IDLER PULLEY AND TENSION SPRING**

- (a) Install the pulley with the bolt. Do not tighten the bolt yet.

**HINT:** Use a bolt 42 mm (1.65 in.) in length.

- (b) Install the tension spring.
- (c) Pry the pulley toward the left as far as it will go and tighten the bolt.
- (d) Check that the idler pulley moves smoothly.

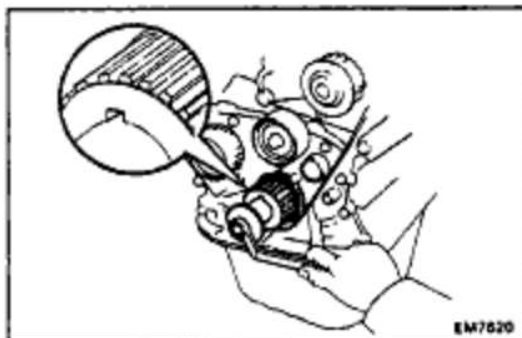
**5. TEMPORARILY INSTALL TIMING BELT**

**NOTICE:** The engine should be cold.

- (a) Using the crankshaft pulley bolt, turn the crankshaft and position the key groove of the crankshaft timing pulley upward.

- (b) Remove any oil or water on the crankshaft pulley, oil pump pulley, water pump pulley, No. 1 idler pulley, No. 2 idler pulley and keep them clean.

- (c) Install the timing belt on the crankshaft timing pulley, oil pump pulley, No.1 idler pulley, water pump pulley and No.2 idler pulley.

**HINT (When re-using timing belt):** Align the points marked during removal, and install the belt with the arrow pointing in the direction of engine revolution.

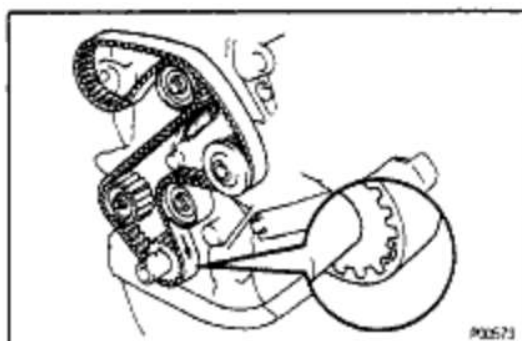

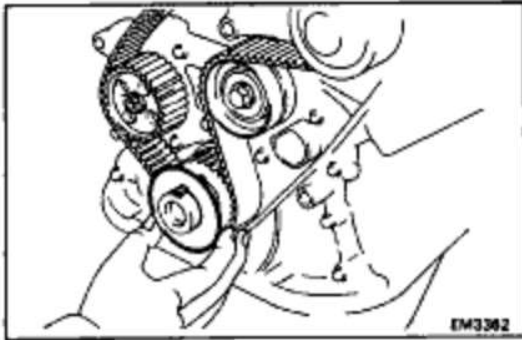

#### 6. INSTALL TIMING BELT GUIDE

Install the guide, facing the cup side outward.

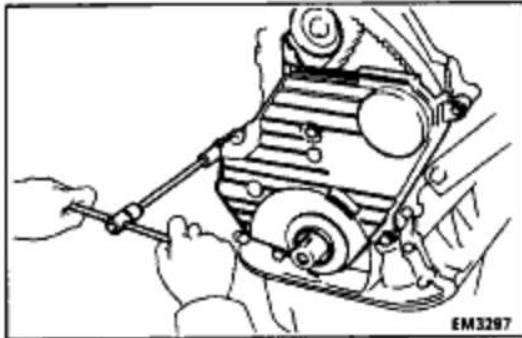

#### 7. INSTALL NO.1 TIMING BELT COVER

- (a) Install the gasket to the timing belt cover.
- (b) Install the timing belt cover with the 4 bolts.

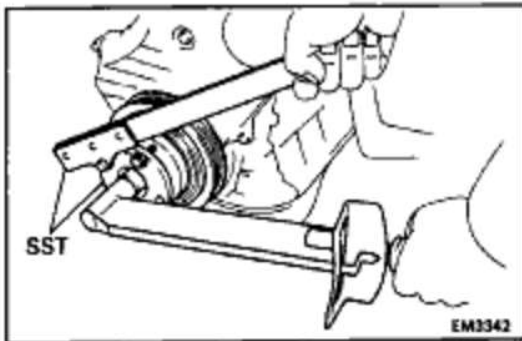

#### 8. INSTALL CRANKSHAFT PULLEY

- (a) Align the pulley set key with the key groove of the pulley, and slide on the pulley.
- (b) Using SST, install the pulley bolt.  
SST 09213-54015 (91651 -60855)  
09330-00021

**Torque: 108 N-m (1,100 kgf-cm, 80 ft-lbf)**

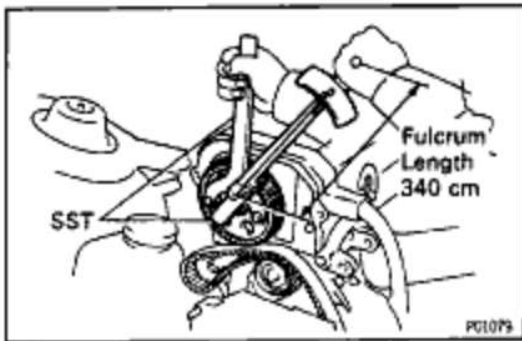

#### 9. INSTALL CAMSHAFT TIMING PULLEY

- (a) Align the camshaft knock pin with the knock pin groove of the pulley, and slide on the timing pulley.
- (b) Using SST, install the plate washer and bolt.  
SST 09249 - 63010 and 09278 - 54012

**Torque: 37 N-m (380 kgf-cm, 27 ft-lbf)**

**HINT:** Use a torque wrench with a fulcrum length of 340 cm (13.39 in.)

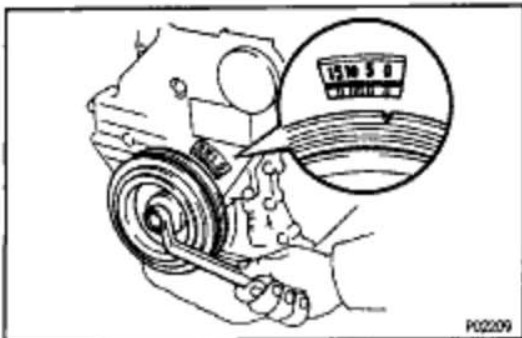

#### 10. SET No.1 CYLINDER TO TDC/COMPRESSION

- (a) Turn the crankshaft pulley, and align its groove with timing mark "0" of the No.1 timing belt cover.

## EG1-36

## 5S-FE ENGINE - ENGINE MECHANICAL

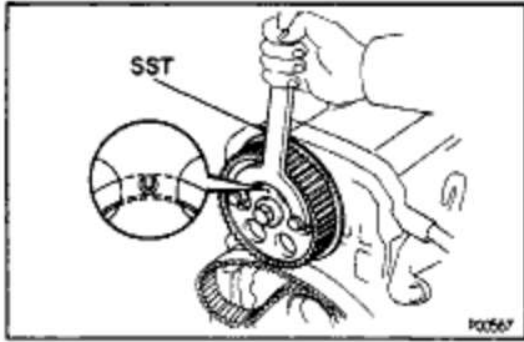

- (b) Using SST, turn the camshaft, and align the hole of the camshaft timing pulley with the timing mark of the bearing cap.

SST 09278-54012

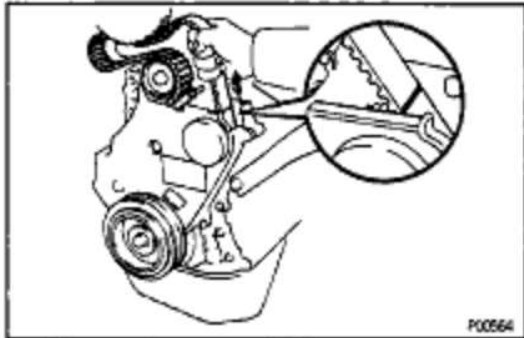

### 11. INSTALL TIMING BELT

HINT. (When re-using timing belt):

- Check that the matchmark on the timing belt matches the end of the No.1 timing belt cover. If the matchmark does not align, shift the meshing of the timing belt and crankshaft timing pulley until they align. (See page [EG1-29](#))

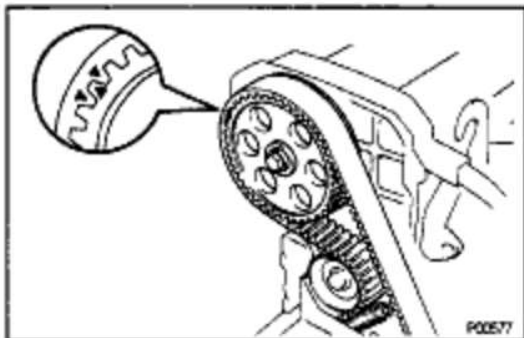

- Align the matchmarks of the timing belt and camshaft timing pulley.

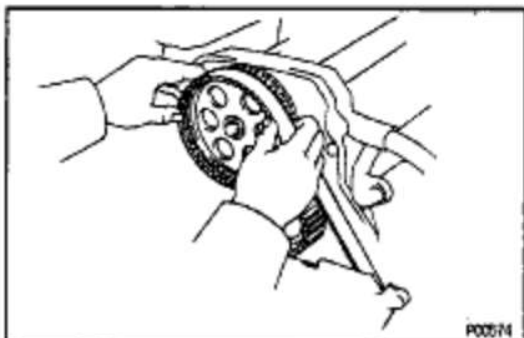

- (a) Remove any oil or water on the camshaft timing pulley, and keep it clean.

- (b) Install the timing belt, and check the tension between the crankshaft timing pulley and camshaft timing pulley.

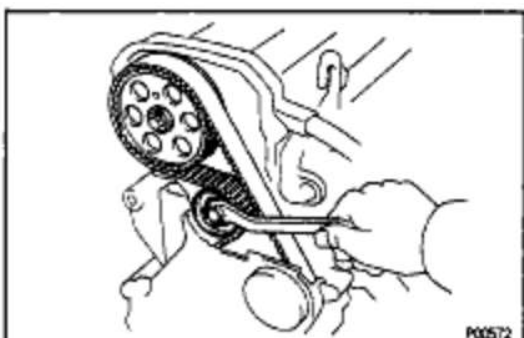

### 12. CHECK VALVE TIMING

- (a) Loosen the No.1 idler pulley bolt 1/2 turn.

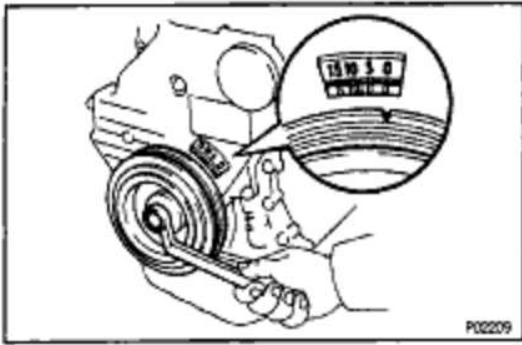

- (b) Turn the crankshaft pulley 2 revolutions from TDC to TDC.

**NOTICE:** Always turn the crankshaft clockwise.



- (c) Check that each pulley aligns with the timing marks as shown in the illustration..  
If the timing marks do not align, remove the timing belt and reinstall it.

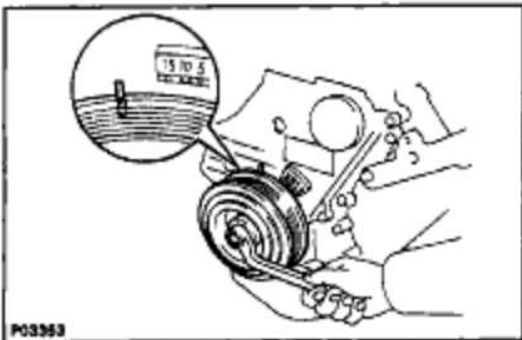

- (d) w/ Green Tension Spring:

Slowly turn the crankshaft pulley 1 and 7/8 revolutions, and align its groove with the mark at 45° BTDC (for No.1 cylinder) of the No.1 timing belt cover.

**NOTICE:** Always turn the crankshaft clockwise.

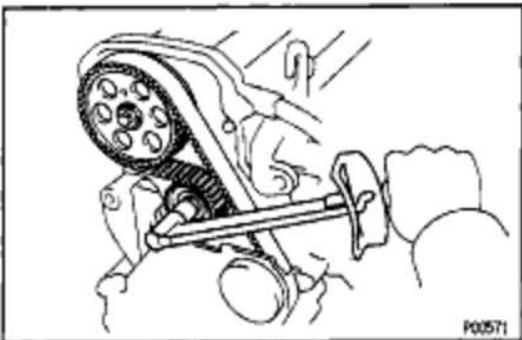

- (e) Torque the mounting bolt of the No.1 idler pulley.  
**Torque:** 42 N-m (425 kgf-cm, 31 ft-lbf)

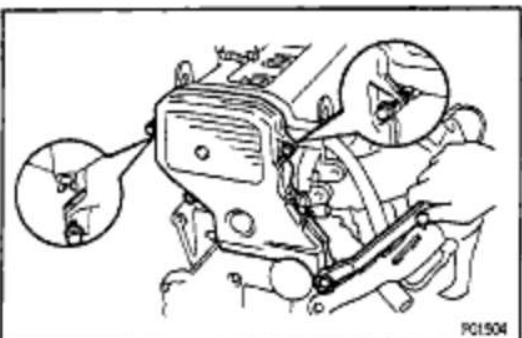

### 13. INSTALL NO.2 TIMING BELT COVER

- (a) Install the 2 gaskets to the No. 1 and No.2 belt covers.  
(b) install the belt cover with the 5 bolts.  
(c) Align the 2 clamps of the engine wire with cover mounting bolts.

## EG1-38

## 5S-FE ENGINE - ENGINE MECHANICAL

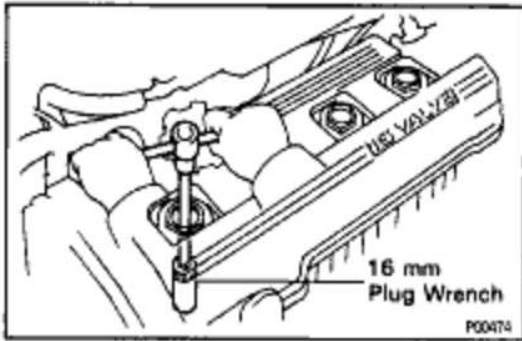
**14. INSTALL SPARK PLUGS**

- (a) Using a 16 mm plug wrench, install the spark plug.
- (b) Connect the high-tension cords.

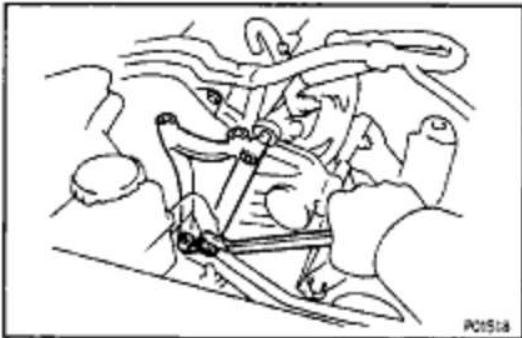
**15. INSTALL NO.2 ENGINE MOUNTING BRACKET**

- (a) Temporarily install the No.2 engine mounting bracket with the 2 bolts.

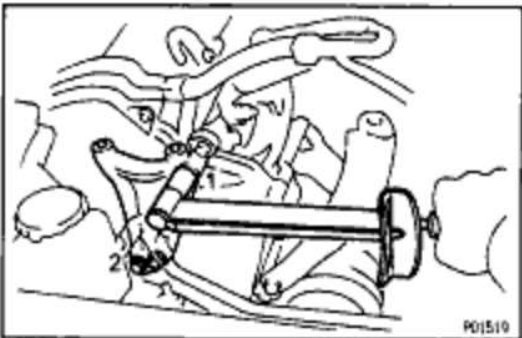

- (b) Install the remaining bolt.
- (c) Tighten the 3 bolts in the sequence shown.  
**Torque: 52 N-m (530 kgf-cm, 38 ft-lbf)**

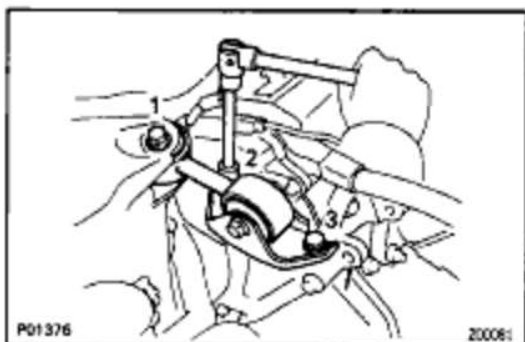
**16. CONNECT CONNECTOR TO GROUND WIRE ON RH FENDER APRON****17. INSTALL ENGINE MOVING CONTROL ROD**

- (a) Temporarily install the engine moving control rod with the 3 bolts in the sequence shown.

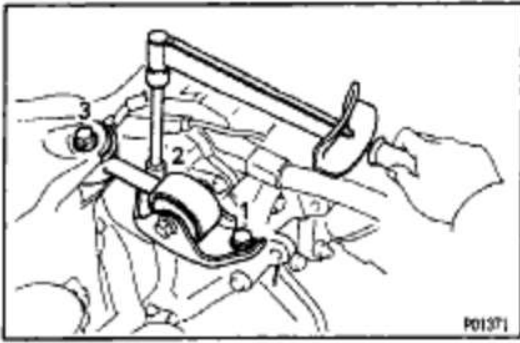

(b) Tighten the 3 bolts in the sequence shown.  
Torque: 64 N-m (650 kgf-cm. 47 ft-lbf)

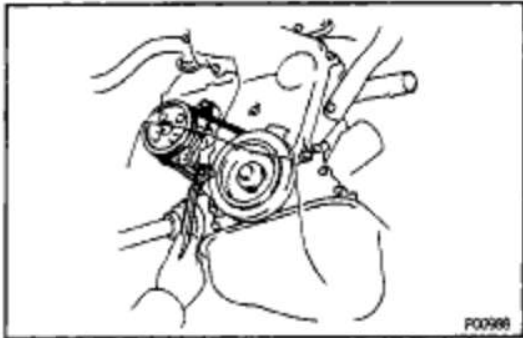

### 18. INSTALL AND ADJUST PS DRIVE BELT

Install the drive belt with the pivot and adjusting bolts.

Drive belt tension:

New belt

$125 \pm 25$  lbf

Used belt

$80 \pm 20$  lbf

### 19. INSTALL RH FENDER APRON SEAL

### 20. INSTALL RH FRONT WHEEL

### 21. INSTALL GENERATOR (See page [CH-24](#))

Drive belt tension:

w/ A/C

New belt

$175 \pm 5$  lbf

Used belt

$130 \pm 10$  lbf

w/o A/C

New belt

$125 \pm 25$  lbf

Used belt

$95 \pm 20$  lbf

### 22. INSTALL ENGINE COOLANT RESERVOIR TANK

### 23. CONNECT NEGATIVE (-) TERMINAL CABLE TO BATTERY

# CYLINDER HEAD COMPONENTS FOR REMOVAL AND INSTALLATION

MODEL-07

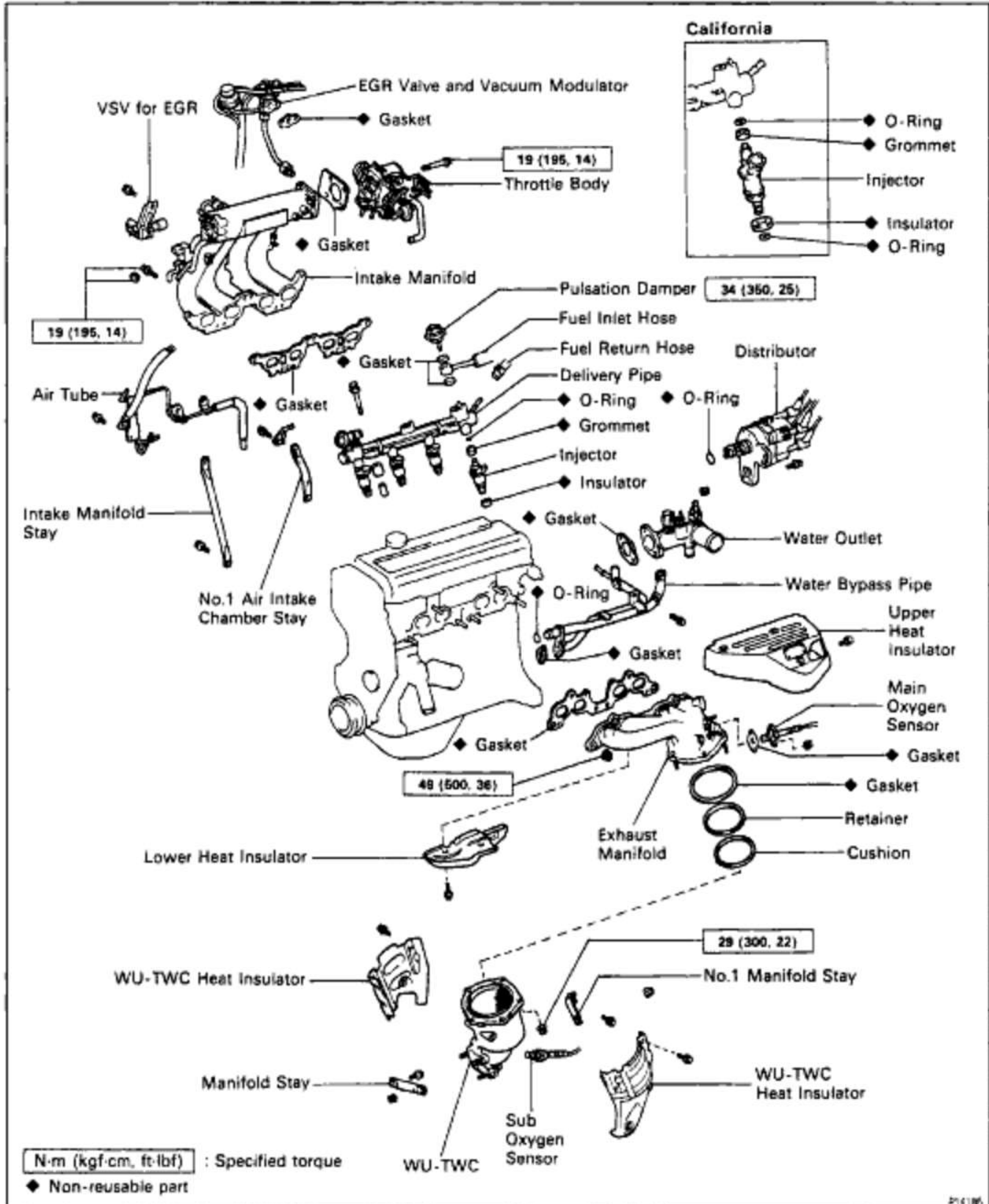



### COMPONENTS (Cont'd)

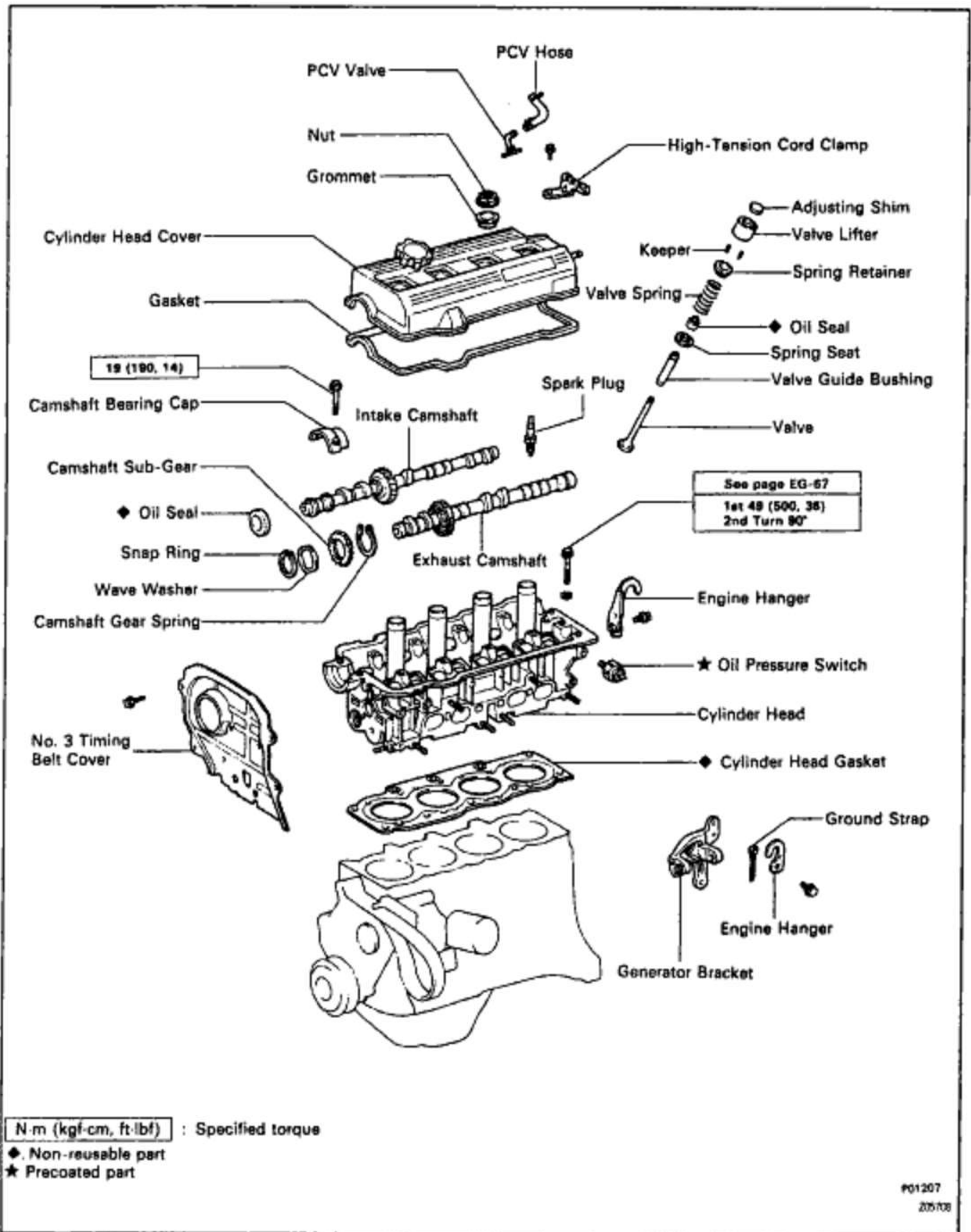

## EG1-42

## 5S-FE ENGINE - ENGINE MECHANICAL

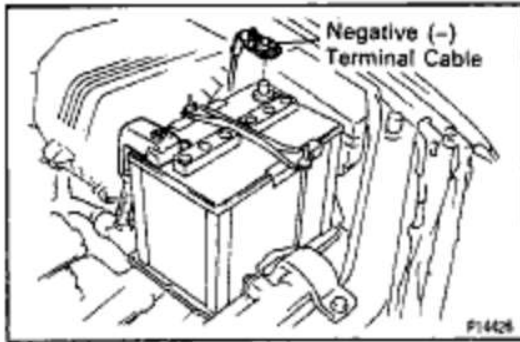

## CYLINDER HEAD REMOVAL

(See Components for Removal and Installation)

### 1. DISCONNECT NEGATIVE (-) TERMINAL CABLE FROM BATTERY

**CAUTION:** Work must be started after 90 seconds from the time the ignition switch is turned to the "LOCK" position and the negative (-) terminal cable is disconnected from the battery.

### 2. DRAIN ENGINE COOLANT

### 3. A/T:

DISCONNECT THROTTLE CABLE FROM THROTTLE BODY

### 4. DISCONNECT ACCELERATOR CABLE FROM THROTTLE BODY

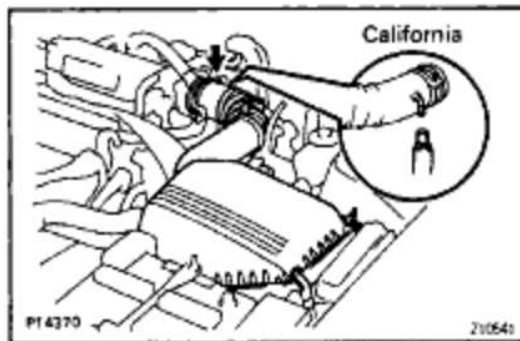

### 5. REMOVE AIR CLEANER CAP, RESONATOR AND AIR CLEANER HOSE

- (a) Disconnect the intake air temperature sensor connector.
- (b) California only:  
Disconnect the air hose from the air cleaner hose.
- (c) Loosen the air cleaner hose clamp bolt.
- (d) Disconnect the 4 air cleaner cap clips.
- (e) Disconnect the air cleaner hose from the throttle body, and remove the air cleaner cap together with the resonator and air cleaner hose.

### 6. REMOVE GENERATOR (See page CH-10)

### 7. REMOVE DISTRIBUTOR

(See page IG-13 end 32)

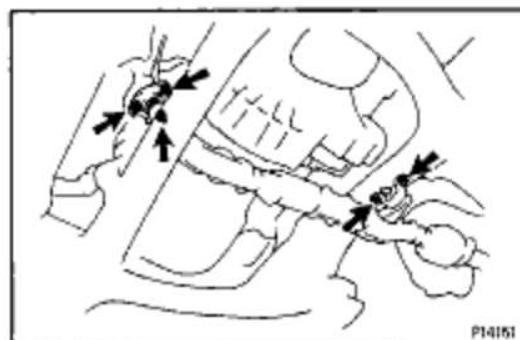

### 8. DISCONNECT FRONT EXHAUST PIPE

- (a) Loosen the 2 bolts, and disconnect the bracket.
- (b) Using a 14 mm deep socket wrench, remove the 3 nuts holding the front exhaust pipe to the WU-TWC.
- (c) Disconnect the front exhaust pipe and gaskets.

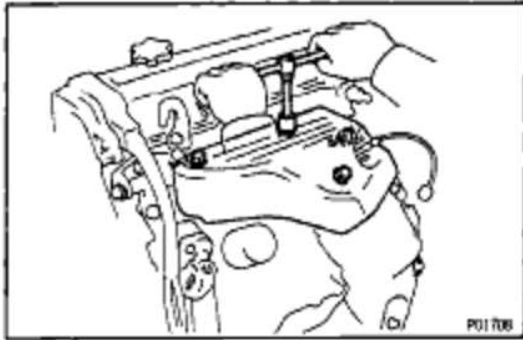

### 9. REMOVE EXHAUST MANIFOLD AND WARM UP

#### THREE-WAY CATALYTIC CONVERTER ASSEMBLY

- (a) Disconnect the main oxygen and sub oxygen sensor connectors.
- (b) Remove the 4 bolts and upper heat insulator.

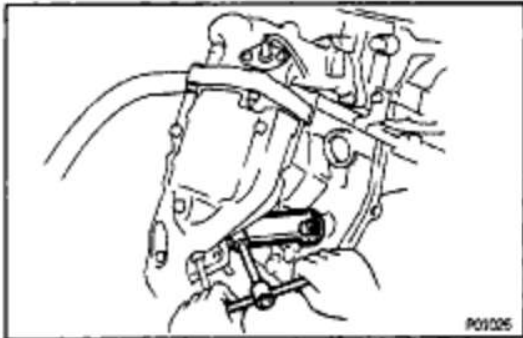

- (c) Remove the bolt, nut and No. 1 manifold stay.

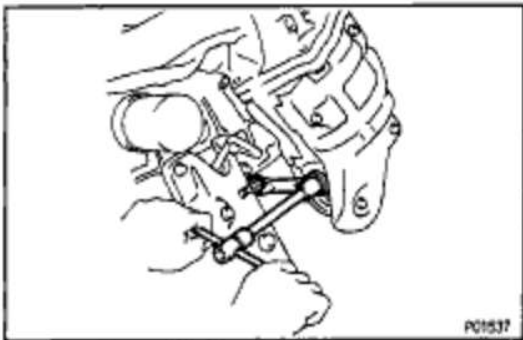

- (d) Remove the bolt, nut and manifold stay.

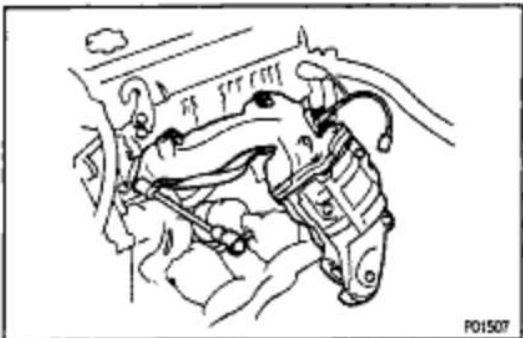

- (e) Remove the 6 nuts, the exhaust manifold and WU - TWC assembly.

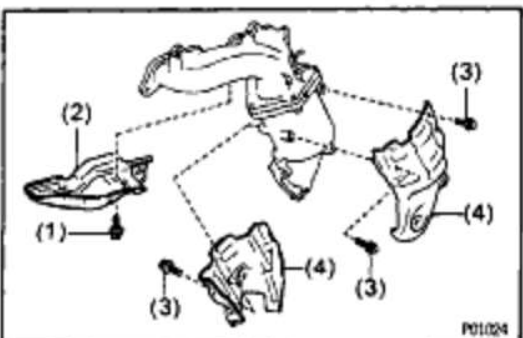

### 10. SEPARATE EXHAUST MANIFOLD AND WARM UP THREE-WAY CATALYTIC CONVERTER

Remove the following parts:

- (1) 3 bolts
- (2) Manifold lower heat insulator
- (3) 8 bolts
- (4) 2 WU-TWC heat insulators

## EG1-44

## 5S-FE ENGINE - ENGINE MECHANICAL

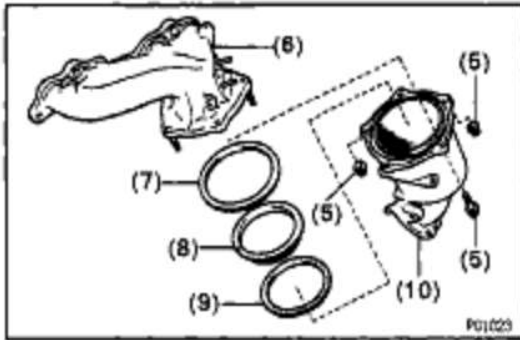

- (5) 3 bolts and 2 nuts
- (6) Exhaust manifold
- (7) Gasket
- (8) Retainer
- (9) Cushion
- (10) WU-TWC

#### 11. DISCONNECT OIL PRESSURE SWITCH CONNECTOR

#### 12. DISCONNECT ENGINE WIRE (FOR OXYGEN SENSORS) FROM ENGINE HANGER

#### 13. REMOVE WATER OUTLET

- (a) Disconnect the following connectors:
  - (1) Engine coolant temperature sender gauge connector
  - (2) Engine coolant temperature sensor connector
- (b) Disconnect the following hoses:
  - (1) Upper radiator hose
  - (2) Water bypass pipe hose
  - (3) Heater water hose
  - (4) IAC water bypass hose
  - (5) 2 TVV (for EVAP) vacuum hoses

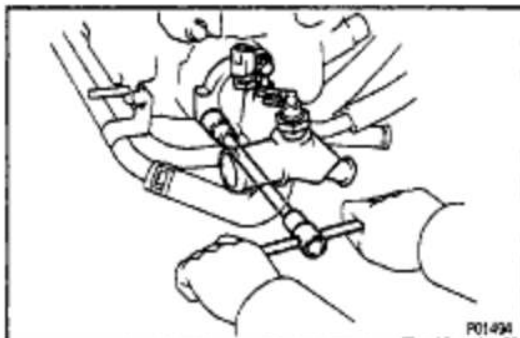
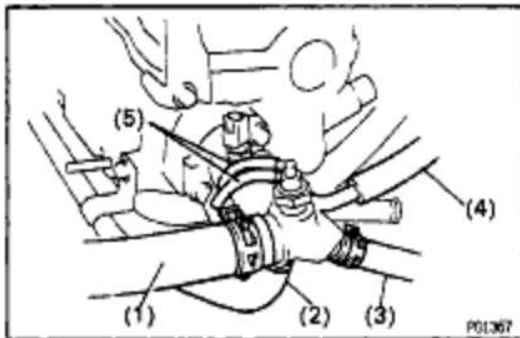

- (c) Remove the 2 bolts, water outlet and gasket.

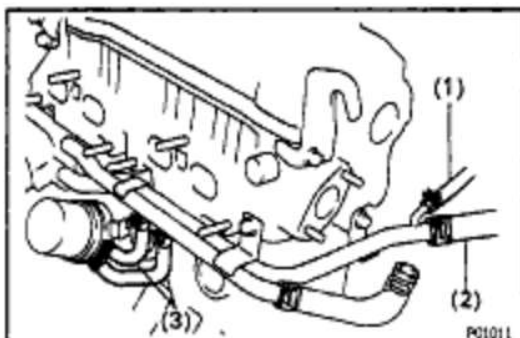

#### 14. REMOVE WATER BYPASS PIPE

- (a) Disconnect the following hoses:
  - (1) IAC water bypass hose
  - (2) Heater water hose
  - (3) w/ Oil Cooler:
    - 2 oil cooler water bypass hoses

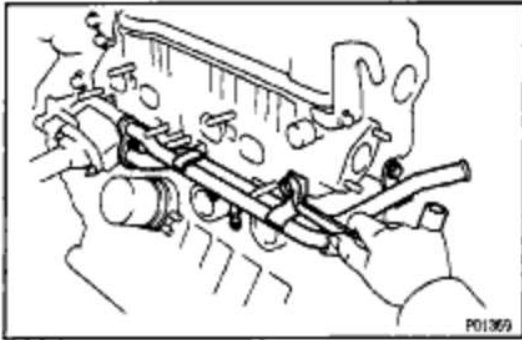

- (b) Remove the 2 bolts, 2 nuts, water bypass pipe and gasket.
- (c) Remove the O-ring from the water bypass hose.

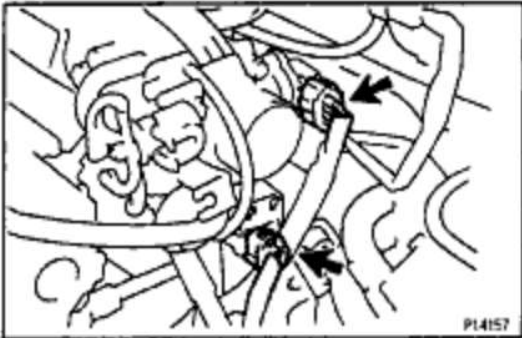

### 15. REMOVE THROTTLE BODY

- (a) Disconnect the throttle position sensor connector.
- (b) Disconnect the IAC valve connector.

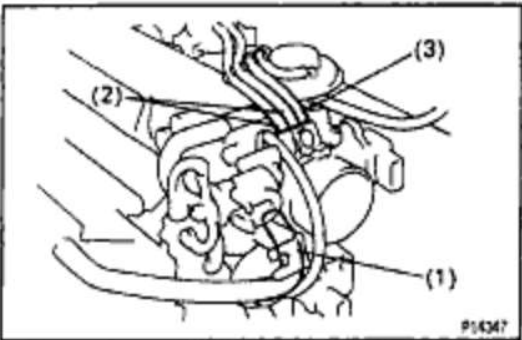

- (c) Disconnect the following hoses from the throttle body.
  - (1) PCV hose
  - (2) 2 vacuum hoses from EGR vacuum modulator
  - (3) Vacuum hose from TVV (for EVAP)

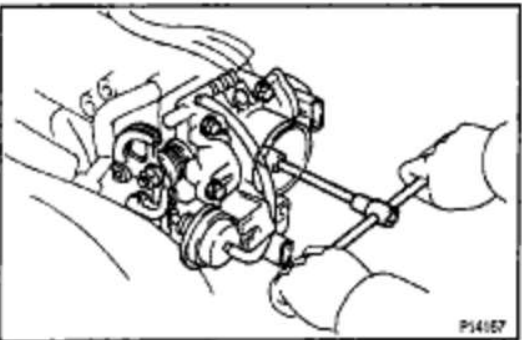

- (d) Type A:  
Remove the 4 bolts.
- (e) Type B:  
Remove the 2 bolts and 2 nuts.

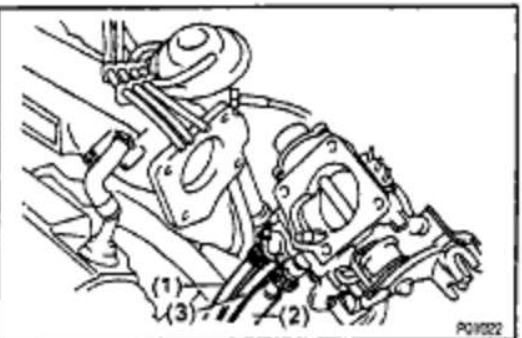

- (f) Disconnect the following hoses from the throttle body, and remove the throttle body.
  - (1) Water bypass hose from water outlet
  - (2) Water bypass hose from water bypass pipe
  - (3) California:  
Air hose from cylinder head  
Except California:  
Air hose from air tube

## EG1-46

## 5S-FE ENGINE - ENGINE MECHANICAL

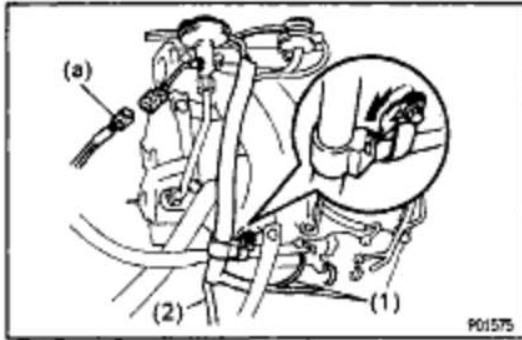
**16. REMOVE EGR VALVE AND VACUUM MODULATOR**

- (a) Disconnect the EGR gas temperature sensor connector.
- (b) Disconnect the following hoses:
  - (1) 2 vacuum hoses from VSV (for EGR)
  - (2) Vacuum hose from charcoal canister
- (c) Disconnect the vacuum hose clamp.

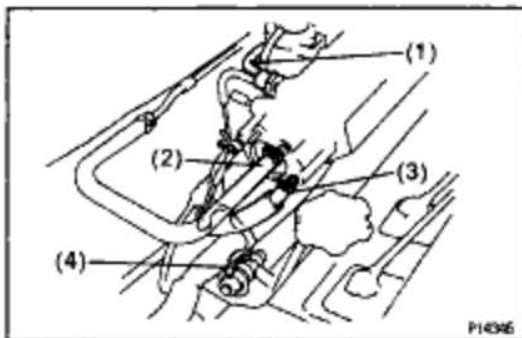

- (d) Loosen the union nut of the EGR pipe, and remove the 2 nuts, EGR valve, vacuum modulator, vacuum hoses assembly and gasket.

**17. DISCONNECT VACUUM HOSES**

Disconnect the following hoses:

- (1) MAP sensor hose from air intake chamber
- (2) Brake booster vacuum hose from air intake chamber
- (3) PS vacuum hose from air intake chamber
- (4) Vacuum sensing hose from fuel pressure regulator 1

**S. W/ A/C:****DISCONNECT A/C IDLE-UP VALVE CONNECTOR****19. EXCEPT CALIFORNIA:****REMOVE AIR TUBE**

- (a) Disconnect the following hoses from the air tube:
  - (1) w/ A/C:
    - Air hose from ASV
  - (2) 2 air hoses from PS pump

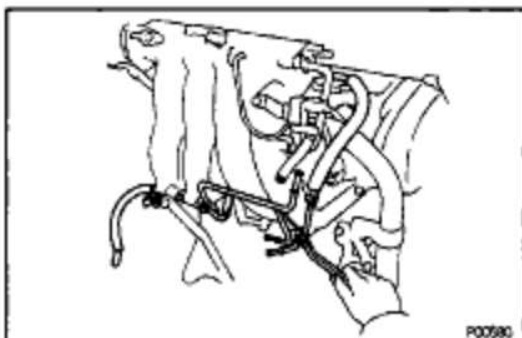
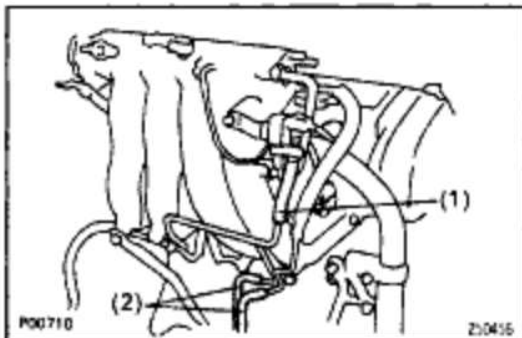

- (b) Remove the 3 bolts, wire clamp and air tube.

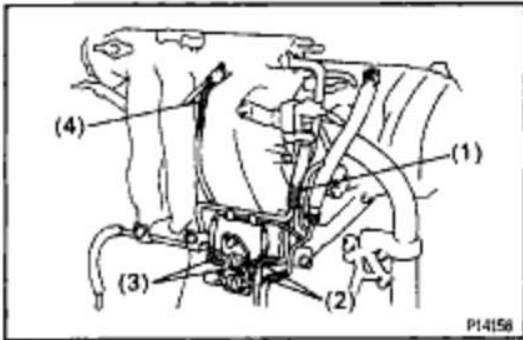

## 20. CALIFORNIA: REMOVE AIR TUBE

- (a) Disconnect the following hoses:
  - (1) w/ A/C:  
A/C hose (from ASV) from air tube
  - (2) 2 air hoses (from PS pump) from air tube
  - (3) California only:  
2 vacuum hoses from VSV (for fuel pressure control)
  - (4) Vacuum hose from air intake chamber
- (b) Remove the 3 bolts, wire clamp and air tube.

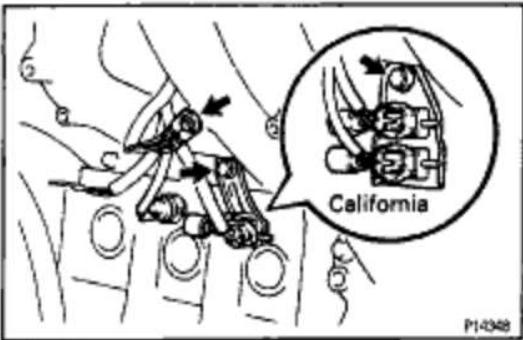
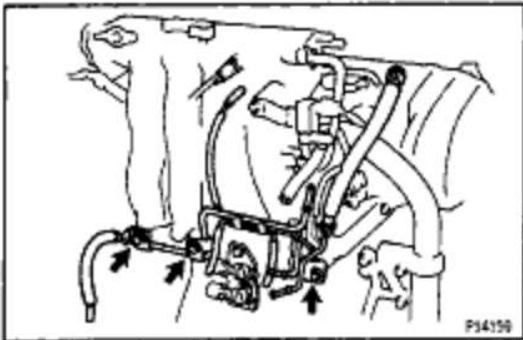

21. DISCONNECT 2 ENGINE WIRE GROUND STRAPS FROM INTAKE MANIFOLD
22. DISCONNECT KNOCK SENSOR AND VSV (FOR EGR) CONNECTORS
23. CALIFORNIA ONLY:  
DISCONNECT VSV (FOR FUEL PRESSURE CONTROL) CONNECTOR
24. REMOVE VSV OR VSV ASSEMBLY

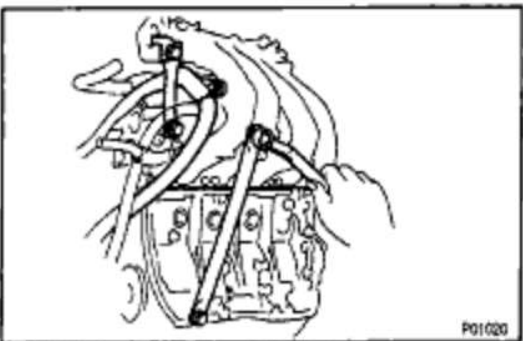

## 25. REMOVE INTAKE MANIFOLD

- (a) Remove the 4 bolts, wire bracket, No.1 air intake chamber and manifold stays.
- (b) Remove the bolt, vacuum hose bracket, and disconnect the engine wire.

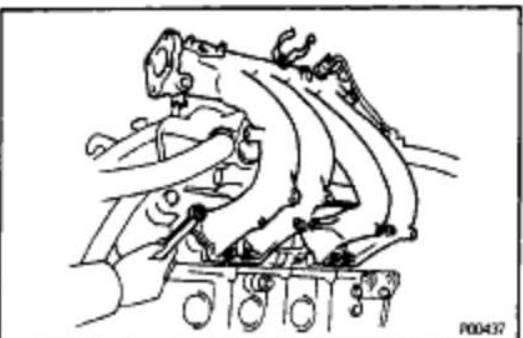

- (c) Remove the 6 bolts, 2 nuts, intake manifold and gasket.

## EG1-48

## 5S-FE ENGINE - ENGINE MECHANICAL

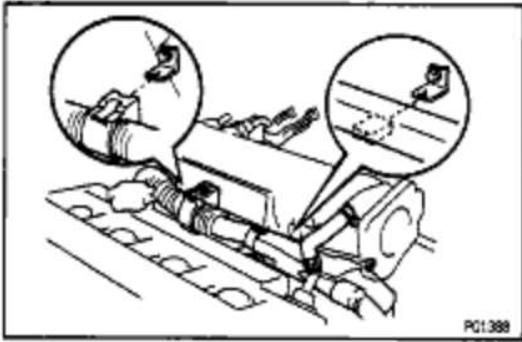

- (d) Disconnect the 2 wire clamps from the wire brackets on the intake manifold.

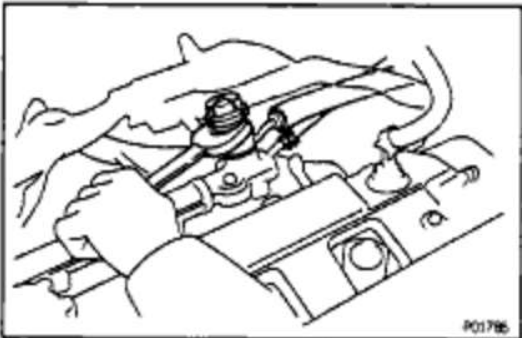
**26. REMOVE DELIVERY PIPE AND INJECTORS**

- (a) Disconnect the injector connectors.  
 (b) Loosen the pulsation damper, and disconnect the fuel inlet hose.  
 (c) Disconnect fuel return hose.

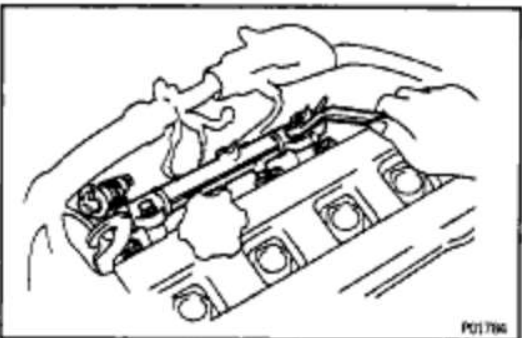

- (d) Remove the 2 bolts and delivery pipe together with the 4 injectors.

**NOTICE: Be careful not to drop the injectors when removing the delivery pipes.**

- (e) Remove the 4 insulators (except California) and 2 spacers from the cylinder head.  
 (f) Pull out the 4 injectors from the delivery pipe.

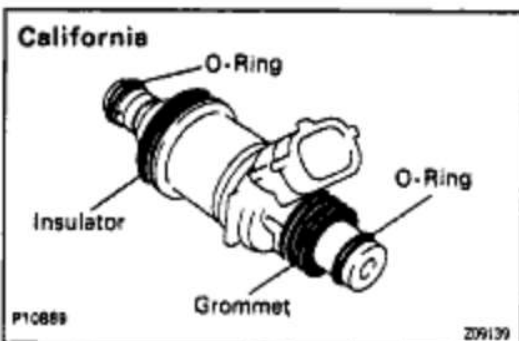

- (g) California:  
 Remove the 2 O-rings, insulator and grommet from each injector.

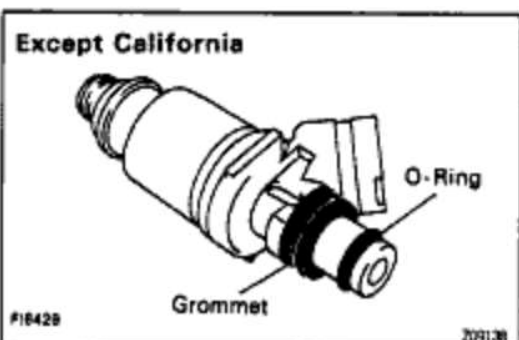

- (h) Except California:  
 Remove the O-ring and grommet from each injector.

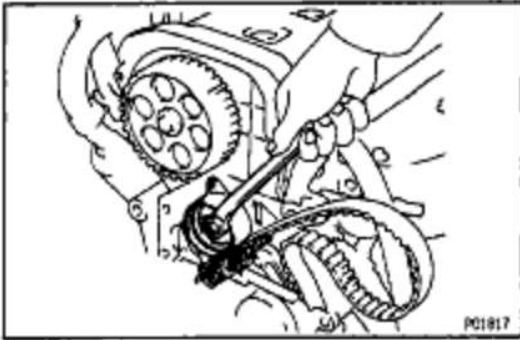

**27. REMOVE CAMSHAFT TIMING PULLEY**

(See steps 2 to 15 on pages EG1-26 to 28)

**28. REMOVE NO. 1 IDLER PULLEY AND TENSION SPRING**

Remove the bolt, pulley and tension spring.

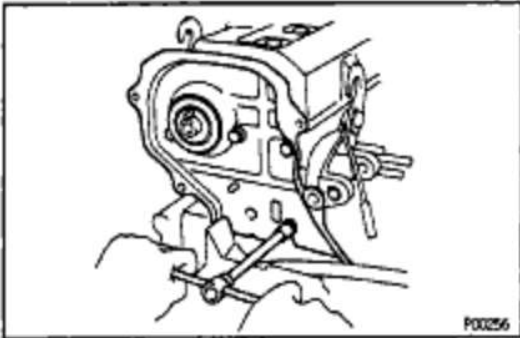
**29. REMOVE NO.3 TIMING BELT COVER**

Remove the 4 bolts and timing and cover.

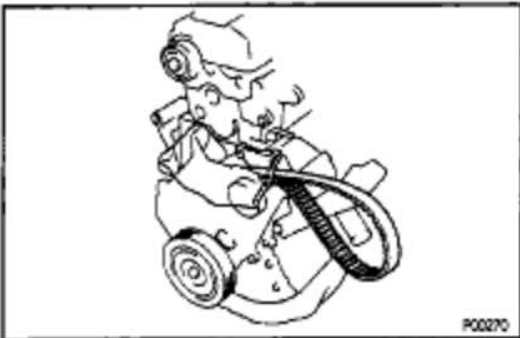
**NOTICE:**

- Support the timing belt, so the meshing of crankshaft timing pulley and timing belt does not shift.
- Be careful not to drop anything inside the timing belt cover.
- Do not allow the belt to come into contact with oil, water or dust.

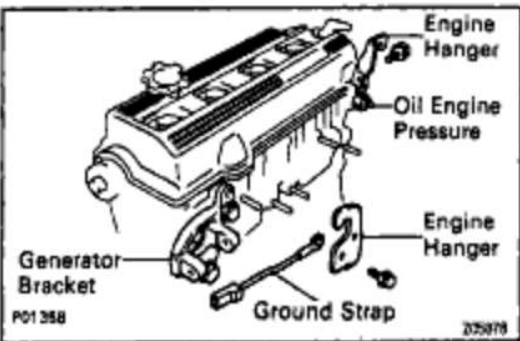
**30. REMOVE ENGINE HANGERS**

Remove the bolt and engine hanger. Remove the 2 engine hangers. Remove the ground strap.

**31. REMOVE GENERATOR BRACKET**

Remove the 3 bolts and generator bracket.

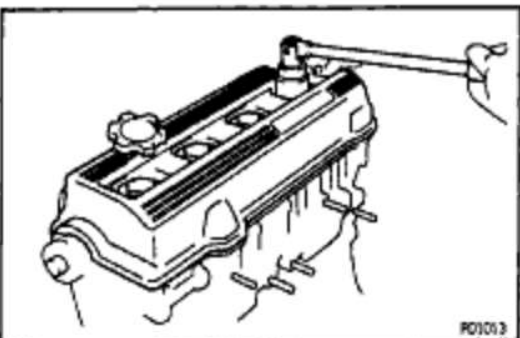
**32. REMOVE OIL PRESSURE SWITCH****33. REMOVE CYLINDER HEAD COVER**

Remove the 4 nuts, grommets, head cover and gasket.

## EG1-50

## 5S-FE ENGINE - ENGINE MECHANICAL

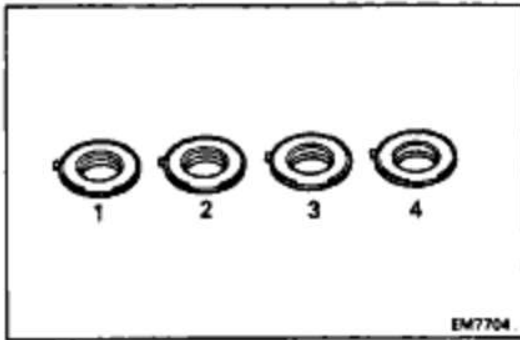

**HINT:** Arrange the grommets in correct order, so that they can be reinstalled into their original positions. This minimizes any possibility of oil leakage due to reuse of grommets.

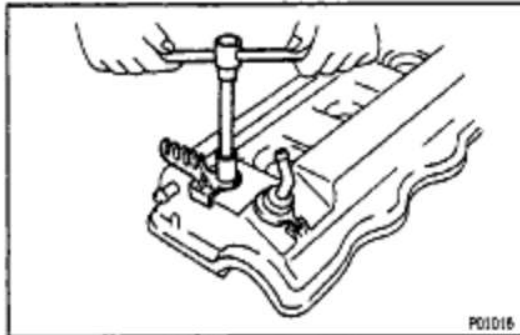

### 34. REMOVE HIGH - TENSION CORDS CLAMP AND PCV VALVE

### 35. REMOVE CAMSHAFTS

**NOTICE:** Since the thrust clearance of the camshaft is small, the camshaft must be kept level while it is being removed. If the camshaft is not kept level, the portion of the cylinder head receiving the shaft thrust may crack or be damaged, causing the camshaft to seize or break. To avoid this, the following steps should be carried out.

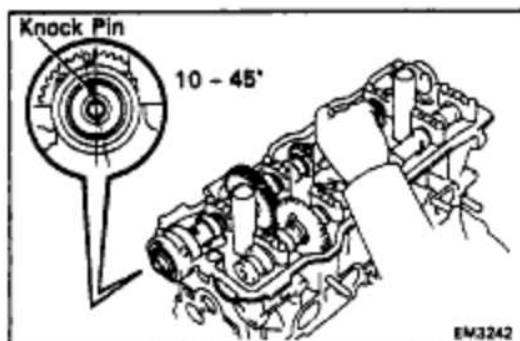

#### A. Remove exhaust camshaft

- (a) Set the knock pin of the intake camshaft at 10–45° BTDC of camshaft position.

**HINT:** The above angle allows No.2 and No.4 cylinder cam lobes of the exhaust camshaft to push their valve lifters evenly.

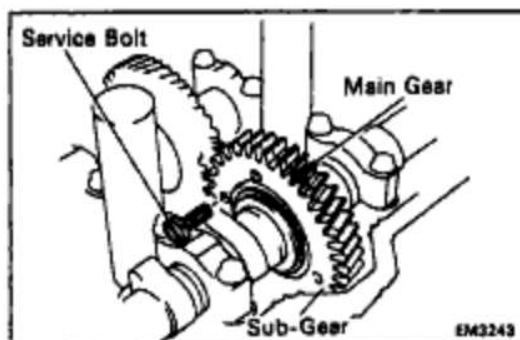

- (b) Secure the exhaust camshaft sub gear to drive gear with a service bolt.

Recommended service bolt:

Thread diameter 6 mm

Thread pitch 1.0 mm

Bolt length 16–20 mm (0.63–0.79 in.)

**HINT:** When removing the camshaft, make sure that the torsional spring force of the sub gear has been eliminated by the above operation.

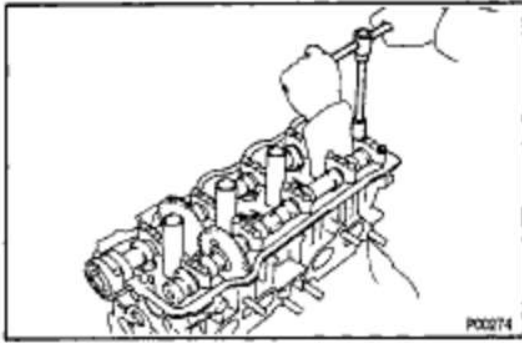

(c) Remove the 2 bolts and rear bearing cap.

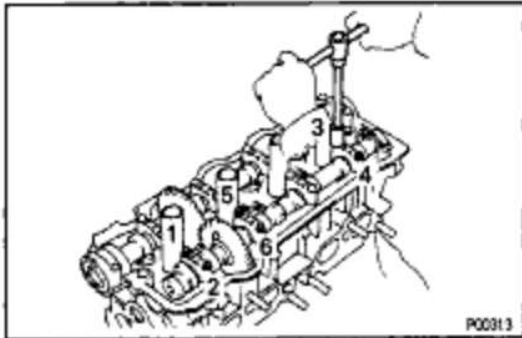

(d) Uniformly loosen and remove the 6 bolts on the No. 1, No.2 and No.4 bearing caps in several passes in the sequence shown.

**NOTICE: Do not remove the No.3 bearing cap bolts at this stage.**

(e) Remove the No. 1, No.2 and No.4 bearing caps.

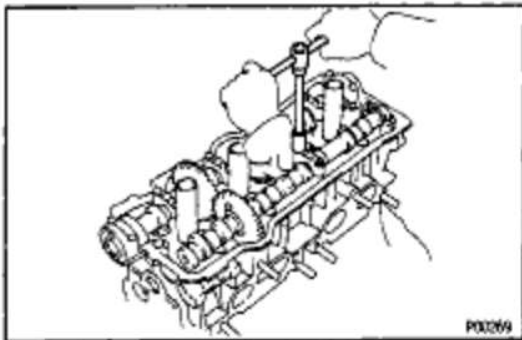

(f) Alternately loosen and remove the 2 bolts on the No. 3 bearing cap.

**HINT:**

- As the 2 No.3 bearing cap bolts are loosened, make sure that the camshaft is lifted out straight and level.
- If the camshaft is not being lifted out straight and level, retighten the 2 No.3 bearing cap bolts. Then reverse the order of above steps from (f) to (a) and reset the knock pin of the intake camshaft at 10-45° BTDC, and repeat steps from

(b) to

(f) once again.

**NOTICE: Do not pry on or attempt to force the camshaft with a tool or other object.**

(g) Remove the No.3 bearing cap and exhaust camshaft.

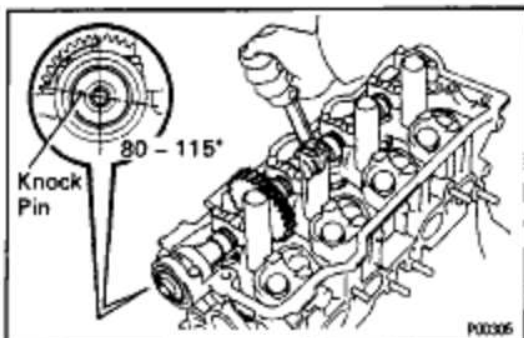

**B. Remove intake camshaft**

(a) Set the knock pin of the intake camshaft at 80-115° BTDC of camshaft angle.

**HINT:** The above angle allows the No.1 and No.3 cylinder cam lobes of intake camshaft to push their valve lifters evenly.

## EG1-52

## 5S-FE ENGINE - ENGINE MECHANICAL

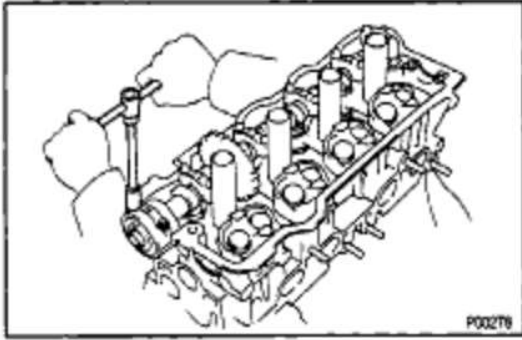

(b) Remove the 2 bolts, front bearing cap and oil seal.

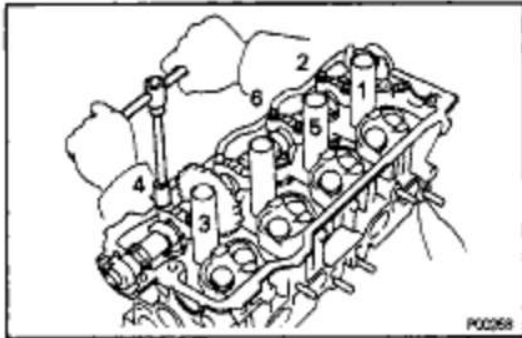

(c) Uniformly loosen and remove the 6 bolts on the No. 1, No. 3 and No. 4 bearing caps in several passes in the sequence shown.

**NOTICE: Do not remove the No. 2 bearing cap bolts at this stage.**

(d) Remove the No. 1, No. 3 and No. 4 bearing caps.

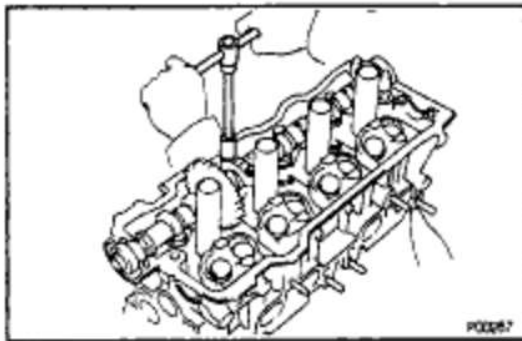

(e) Alternately loosen and remove the 2 bolts on the No. 2 bearing cap.

## HINT:

- As the 2 No. 2 bearing cap bolts are loosened, make sure that the camshaft is lifted out straight and level, after breaking adhesion on the front bearing cap.
- If the camshaft is not being lifted out straight and level, retighten the 2 No. 2 bearing cap bolts. Reverse the order of above steps from (e) to (a) and reset the knock pin of the intake camshaft at 80–115°6TDC, and repeat steps from (b) to (e) once again.

**NOTICE: Do not pry on or attempt to force the camshaft with a tool or other object.**

(f) Remove the No. 2 bearing cap and camshaft.



## 36. DISASSEMBLE EXHAUST CAMSHAFT

(a) Mount the hexagon wrench head portion of the camshaft in a vise.

**NOTICE: Be careful not to damage the camshaft.**

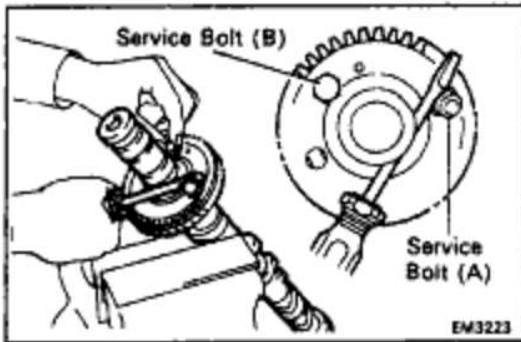

- (b) Insert a service bolt (A) into the service hole of the camshaft sub gear.  
 (c) Using a screwdriver, turn the sub gear clockwise, and remove the service bolt (B).

**NOTICE:** Be careful not to damage the camshaft.

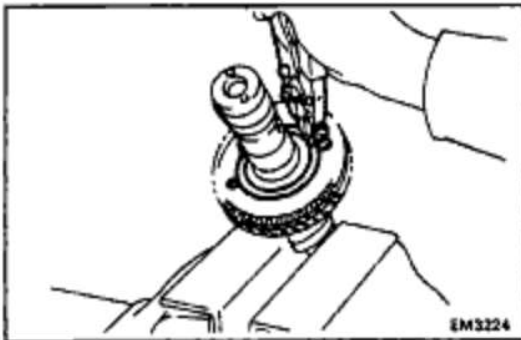

- (d) Using snap ring pliers, remove the snap ring.

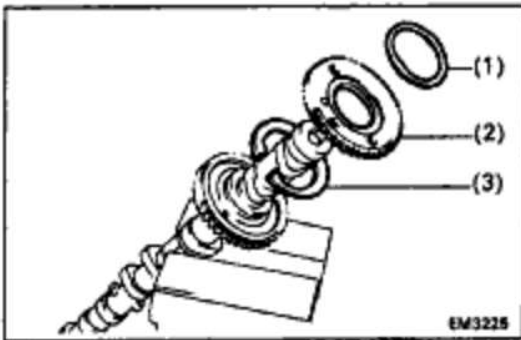

- (e) Remove the following parts:  
 (1) Wave washer  
 (2) Camshaft sub gear  
 (3) Camshaft gear spring

### 37. REMOVE CYLINDER HEAD

- (a) Using SST, uniformly loosen and remove the 10 cylinder head bolts in several passes, in the sequence shown.

SST 09011- 38121

**NOTICE:** Cylinder head warpage or cracking could result from removing bolts in incorrect order.

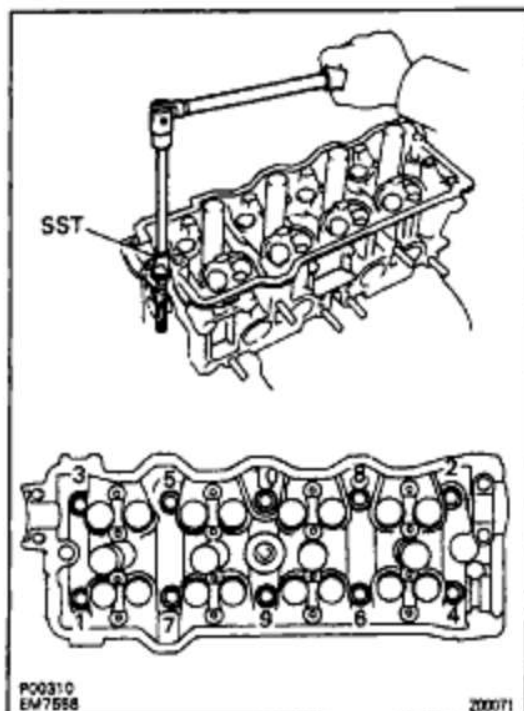

## EG1-54

## 5S-FE ENGINE - ENGINE MECHANICAL

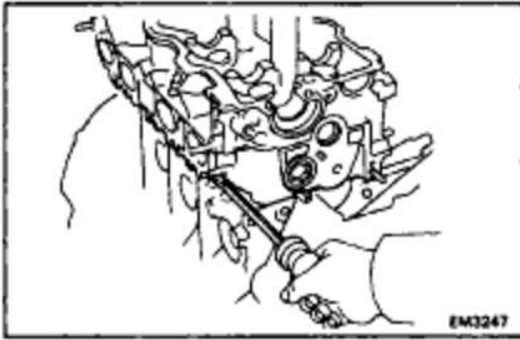

- (b) Lift the cylinder head from the dowels on the cylinder block, and place the cylinder head on wooden blocks on a bench.

HINT: If the cylinder head is difficult to lift off, pry between the cylinder head and cylinder block with a screwdriver.

**NOTICE:** Be careful not to damage the contact surfaces of the cylinder head and cylinder block.

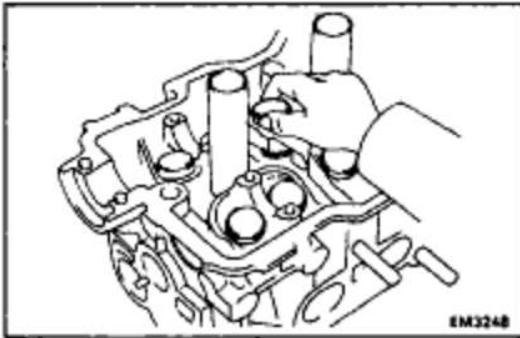

## CYLINDER HEAD DISASSEMBLY

(See Components for Removal and Installation)

### 1. REMOVE VALVE LIFTERS AND SHIMS

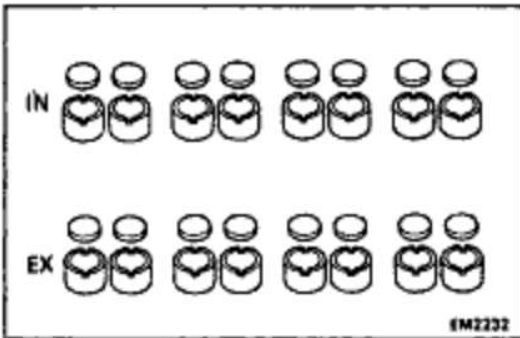

HINT: Arrange the valve lifters and shims in correct order.

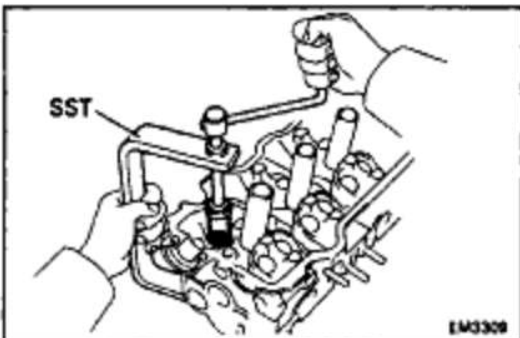

### 2. REMOVE VALVES

- (a) Using SST, compress the valve spring and remove the 2 keepers.

SST 09202 - 70010

- (b) Remove the spring retainer, valve spring, valve and spring seat.



HINT: Arrange the valves, valve springs, spring seats and spring retainers in correct order.

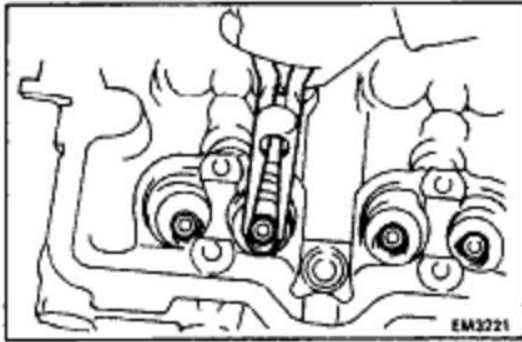

(c) Using needle-nose pliers, remove the oil seal.

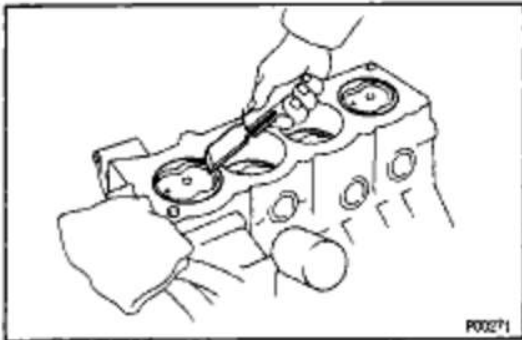

## CYLINDER HEAD COMPONENTS INSPECTION, CLEANING AND REPAIR

### 1. CLEAN TOP SURFACES OF PISTONS AND CYLINDER BLOCK

(a) Turn the crankshaft, and bring each piston to top dead center (TDC). Using a gasket scraper, remove all the carbon from the piston top surface.

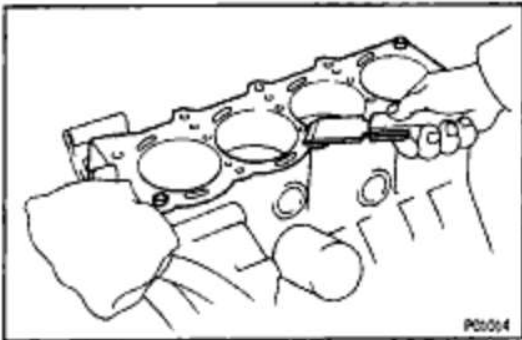

(b) Using a gasket scraper, remove all the gasket material from the cylinder block surface.

(c) Using compressed air, blow carbon and oil from the bolt holes.

**CAUTION:** Protect your eyes when using high pressure compressed air.

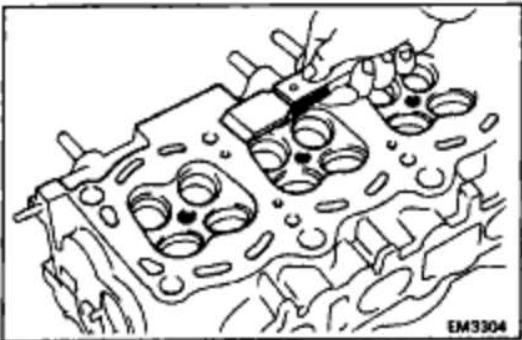

### 2. CLEAN CYLINDER HEAD

#### A. Remove gasket material

Using a gasket scraper, remove all the gasket material from the cylinder block contact surface.

**NOTICE:** Be careful not to scratch the cylinder block contact surface.

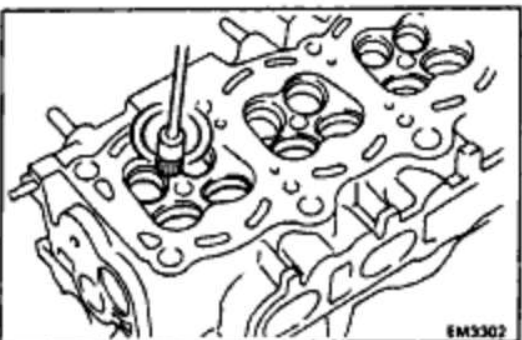

#### B. Clean combustion chambers

Using a wire brush, remove all the carbon from the combustion chambers.

**NOTICE:** Be careful not to scratch the cylinder block contact surface.

## EG1-56

## 5S-FE ENGINE - ENGINE MECHANICAL

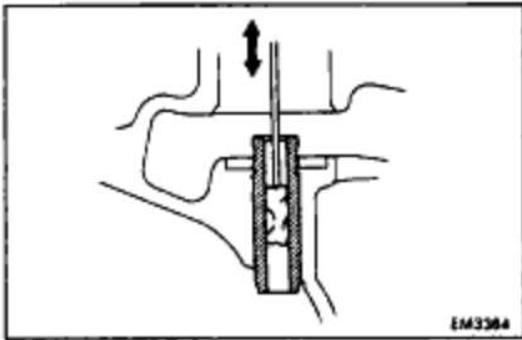
**C. Clean valve guide bushings**

Using a valve guide bushing brush and solvent, clean all the guide bushings.

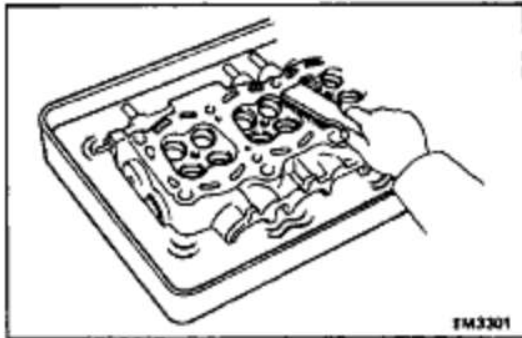
**D. Clean cylinder head**

Using a soft brush and solvent, thoroughly clean the cylinder head.

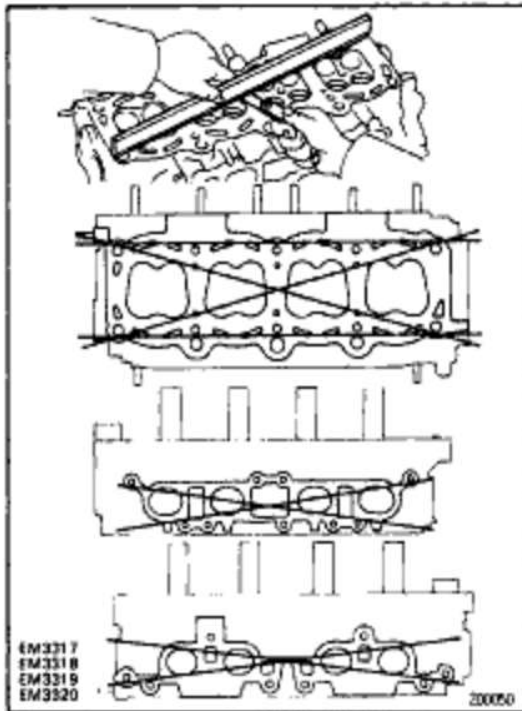
**3. INSPECT CYLINDER HEAD****A. Inspect for flatness**

Using a precision straight edge and thickness gauge, measure the surfaces contacting the cylinder block and the manifolds for warpage.

**Maximum warpage:**

**Cylinder block side**

**0.05 mm (0.0020 in.)**

**Manifold side**

**0.08 mm (0.0031 in.)**

If warpage is greater than maximum, replace the cylinder head.

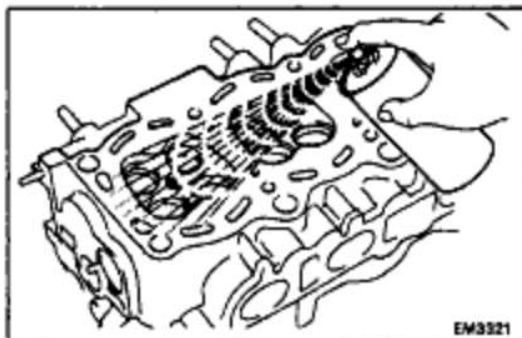
**B. Inspect for cracks**

Using a dye penetrant, check the combustion chambers, intake ports, exhaust ports and cylinder block surface for cracks.

If cracked, replace the cylinder head.



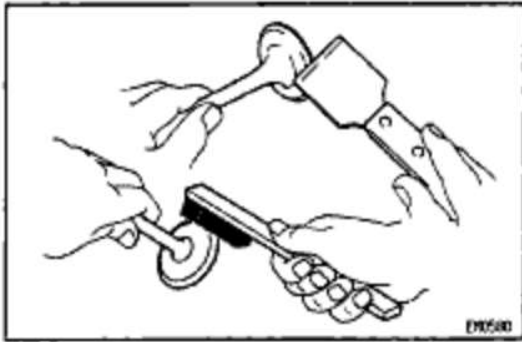

#### 4. CLEAN VALVES

- (a) Using a gasket scraper, chip off any carbon from the valve head.
- (b) Using a wire brush, thoroughly clean the valve.

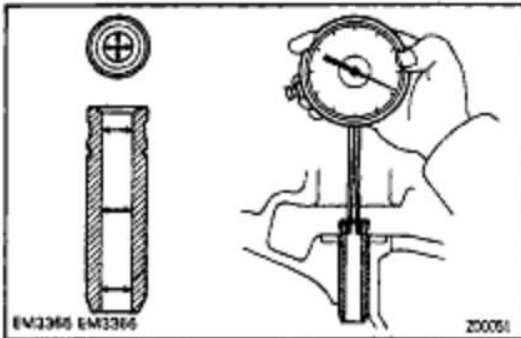

#### 5. INSPECT VALVE STEMS AND GUIDE BUSHINGS

- (a) Using a caliper gauge, measure the inside diameter of the guide bushing.

**Bushing inside diameter:**

**6.010 – 6.030 mm (0.2366 – 0.2374 in.)**

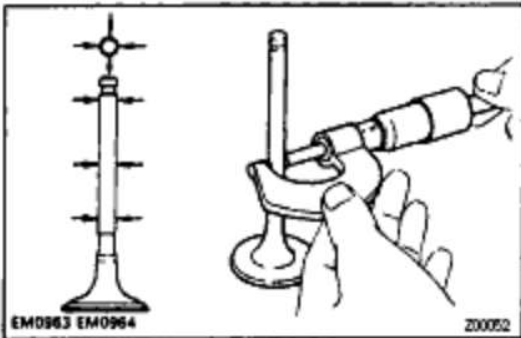

- (b) Using a micrometer, measure the diameter of the valve stem.

**Valve stem diameter:**

**Intake**

**5.970 – 5.985 mm (0.2350 – 0.2356 in.)**

**Exhaust**

**5.965 – 5.980 mm (0.2348 – 0.2354 in.)**

- (c) Subtract the valve stem diameter measurement from the guide bushing inside diameter measurement.

**Standard oil clearance:**

**Intake**

**0.025 – 0.060 mm (0.0010 – 0.0024 in.)**

**Exhaust**

**0.030 – 0.065 mm (0.0012 – 0.0028 in.)**

**Maximum oil clearance:**

**Intake**

**0.08 mm (0.0031 in.)**

**Exhaust**

**0.10 mm (0.0039 in.)**

If the clearance is greater than maximum, replace the valve and guide bushing.

## EG1-58

## 5S-FE ENGINE - ENGINE MECHANICAL

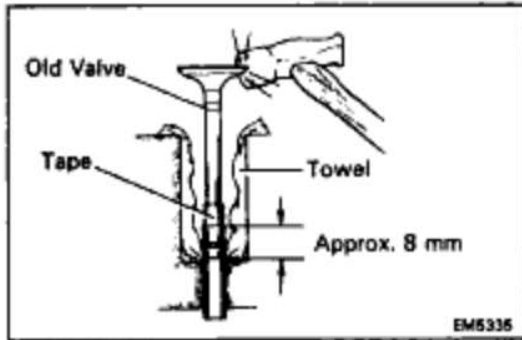

## 6. IF NECESSARY, REPLACE VALVE GUIDE BUSHINGS

### (a) w/ Snap Ring:

Insert an old valve wrapped with tape into the valve guide bushing, and break off the valve guide bushing by hitting it with a hammer. Remove the snap ring.

HINT: Wrap the tape approx. 8 mm (0.31 in.) from the valve stem end.

**NOTICE:** Be careful not to damage the valve lifter hole.

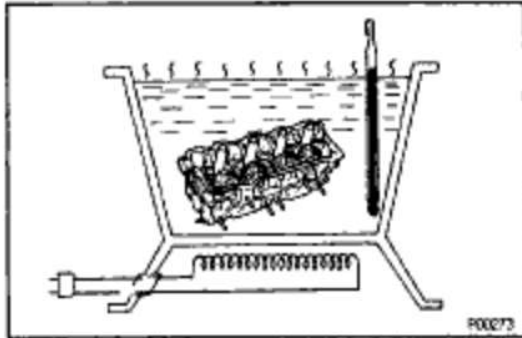

(b) Gradually heat the cylinder head to 80–100°C (176–212°F).

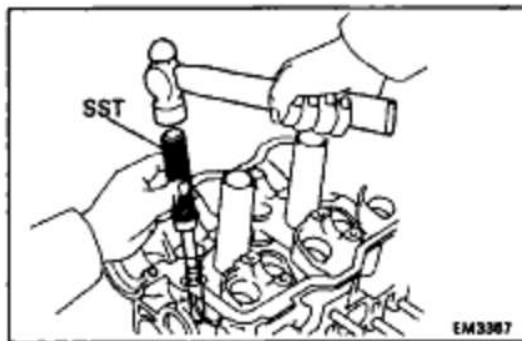

(c) Using SST and a hammer, tap out the guide bushing.  
SST 09201-70010

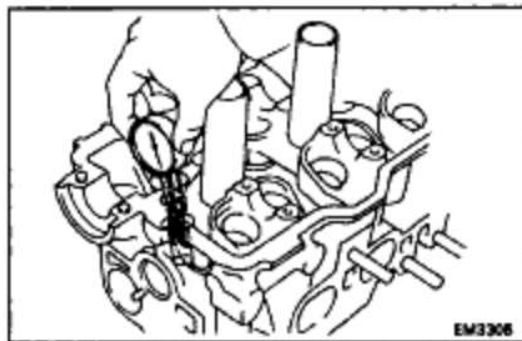

(d) Using a caliper gauge, measure the bushing bore diameter of the cylinder head.

(e) Select a new guide bushing (STD size or O/S 0.05).

If the bushing bore diameter of the cylinder head is greater than 11.027 mm (0.4341 in.), machine the bushing bore to the following dimension:

11.050 – 11.077 mm (0.4350 – 0.4301 in.)

If the bushing bore diameter of the cylinder head is greater than 11.077 mm (0.4361 in.), replace the cylinder head.

Both intake and exhaust

Bushing bore diameter mm (in.)	Bushing size
11.000 – 11.027 10.4331 – 0.4341)	Use STD
11.050 – 11.077 (0.4350 – 0.4361)	Use O/S 0.05

W00208

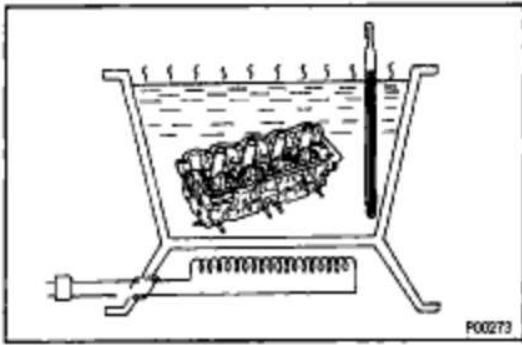

- (f) Gradually heat the cylinder head to 80 –100<sup>o</sup>C (171 – 212<sup>o</sup>F).

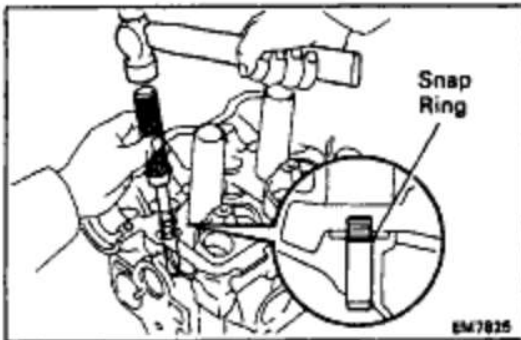

- (g) Using SST and a hammer, tap in a new guide bushing until the snap ring makes contact with the cylinder head.  
SST 09201- 70010

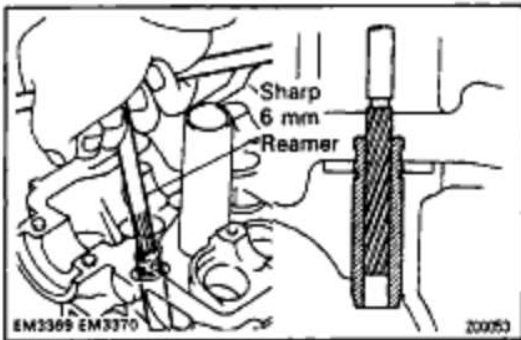

- (h) Using a sharp 6 mm reamer, ream the guide bushing to obtain the standard specified clearance (See page [EG1-57](#)) between the guide bushing and valve stem.

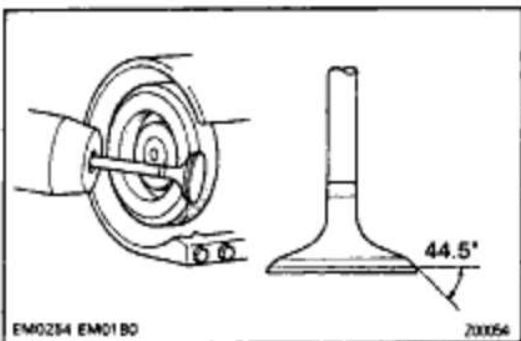

## 7. INSPECT AND GRIND VALVES

- (a) Grind the valve enough to remove pits and carbon.  
(b) Check that the valve is ground to the correct valve face angle.

**Valve face angle:**  
**44.5<sup>o</sup>**

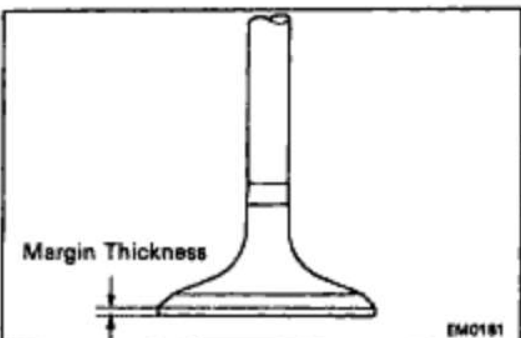

- (c) Check the valve head margin thickness.

**Standard margin thickness:**  
**0.8 – 1.2 mm (0.031 – 0.047 in.)**  
**Minimum margin thickness:**  
**0.5 mm (0.020 in.)**

If the margin thickness is less than minimum, replace the valve.

## EG1-60

## 5S-FE ENGINE - ENGINE MECHANICAL

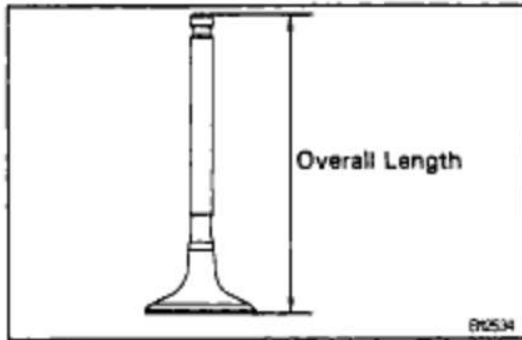

(d) Check the valve overall length.

**Standard overall length:**

**Intake**

**97.60 mm (3.8425 in.)**

**Exhaust**

**98.45 mm (3.8760 in.)**

**Minimum overall length:**

**Intake**

**97.1 mm (3.823 in.)**

**Exhaust**

**98.0 mm (3.858 in.)**

If the overall length is less than minimum, replace the valve.

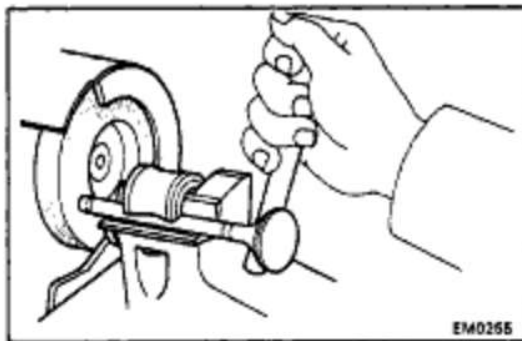

(e) Check the surface of the valve stem tip for wear.

If the valve stem tip is worn, resurface the tip with a grinder or replace the valve.

**NOTICE: Do not grind off more than minimum.**

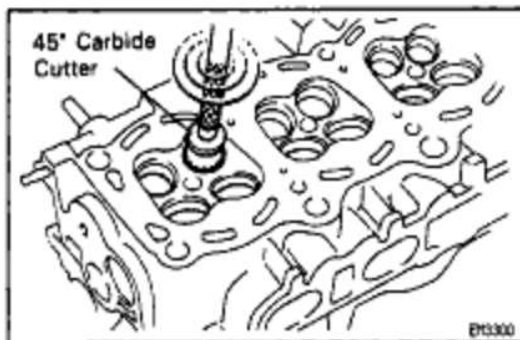

## 8. INSPECT AND CLEAN VALVE SEATS

(a) Using a 45° carbide cutter, resurface the valve seats.

Remove only enough metal to clean the seats.

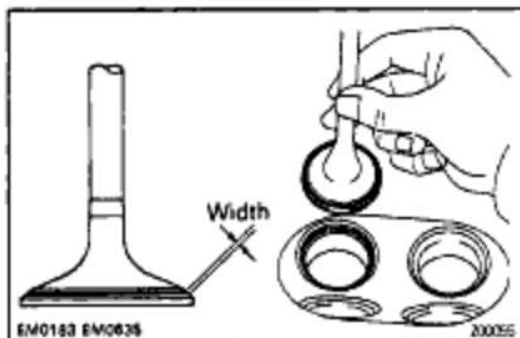

(b) Check the valve seating position.

Apply a light coat of prussian blue (or white lead) to the valve face. Lightly press the valve against the seat. Do not rotate valve.

(c) Check the valve face and seat for the following:

If blue appears 360° around the face, the valve is concentric. If not, replace the valve.

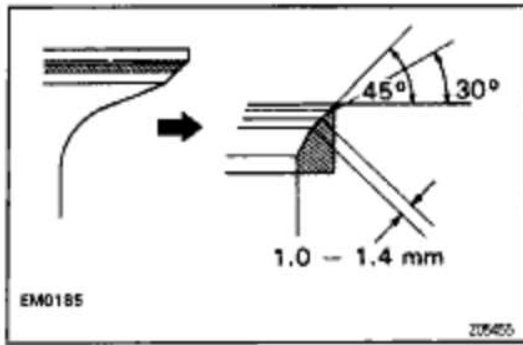

- If blue appears 360° around the valve seat, the guide and face are concentric. If not, resurface the seat.
- Check that the seat contact is in the middle of the valve face with the following width:

**1.0 – 1.4 mm (0.039 – 0.055 in.)**

If not, correct the valve seat as follows:

- (1) If the seating is too high on the valve face, use 30° and 45° cutters to correct the seat.
- (2) If the seating is too low on the valve face, use 75° and 45° cutters to correct the seat.

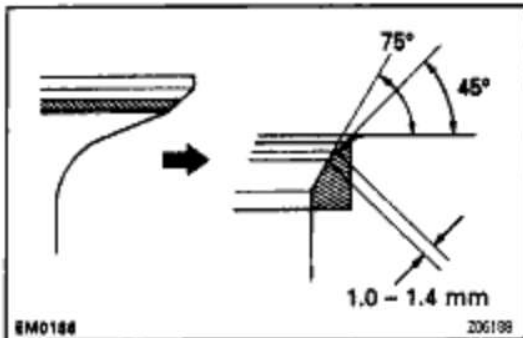

- (d) Hand-lap the valve and valve seat with an abrasive compound.
- (e) After hand-lapping, clean the valve and valve seat.

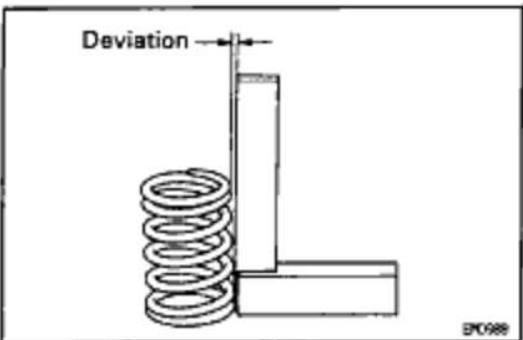

## 9. INSPECT VALVE SPRINGS

- (a) Using a steel square, measure the deviation of the valve spring.

**Maximum deviation:**

**2.0 mm (0.079 in.)**

If the deviation is greater than maximum, replace the valve spring.

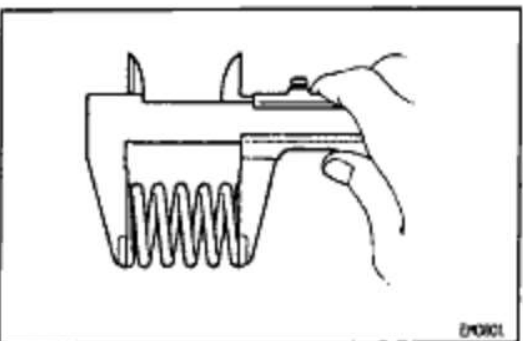

- (b) Using a vernier caliper, measure the free length of the valve spring.

**Free length:**

**41.96 – 41.99 mm (1.6520 – 1.6531 in.)**

If the free length is not as specified, replace the valve spring.

## EG1-62

## 5S-FE ENGINE – ENGINE MECHANICAL

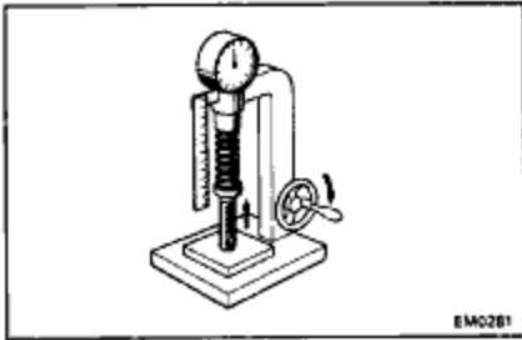

(c) Using a spring tester, measure the tension of the valve spring at the specified installed length.

**Installed tension:**

**164 – 189 N (16.7 – 19.3 kgf, 36.8 – 42.5 lbf)  
at 34.7 mm (1.336 in.)**

If the installed tension is not as specified, replace the valve spring.

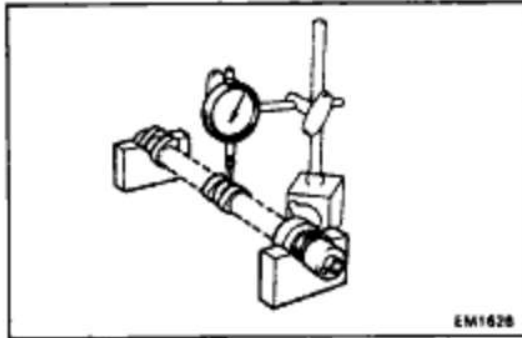

## 10. INSPECT CAMSHAFTS AND BEARINGS

### A. Inspect camshaft for runout

(a) Place the camshaft on V – blocks.

(b) Using a dial indicator, measure the circle runout at the center journal.

**Maximum circle runout:**

**0.04 mm (0.0016 in.)**

If the circle runout is greater than maximum, replace the camshaft.

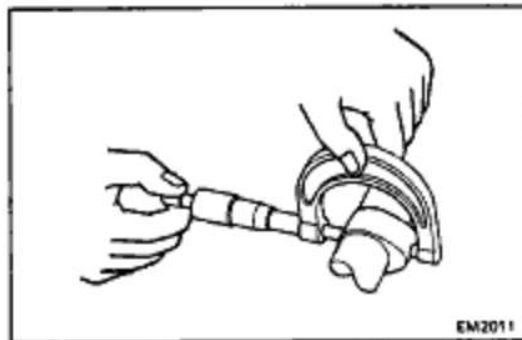

### B. Inspect cam lobes

Using a micrometer, measure the cam lobe height.

**Standard cam lobe height:**

**Intake**

**42.01 – 42.11 mm (1.6539 – 1.6579 in.)**

**Exhaust**

**40.06 – 40.18 mm (1.5772 – 1.5811 in.)**

**Minimum cam lobe height:**

**Intake**

**41.90 mm (1.6496 in.)**

**Exhaust**

**39.95 mm (1.5728 in.)**

If the cam lobe height is less than minimum, replace the camshaft.

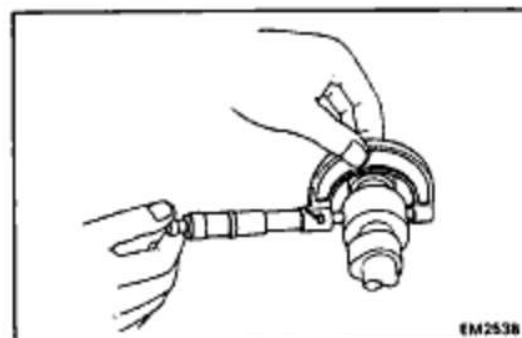

### C. Inspect camshaft journals

Using a micrometer, measure the journal diameter.

**Journal diameter:**

**26.959 – 28.975 mm 11.0814 – 1.0620 in.)**

If the journal diameter is not as specified, check the oil clearance.

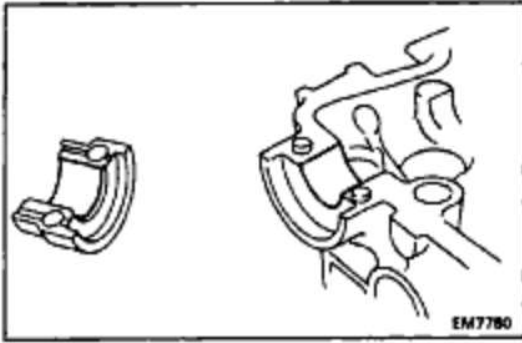

#### D. Inspect camshaft bearings

Check that bearings for flaking and scoring.  
If the bearings are damaged, replace the bearing caps and cylinder head as a set.

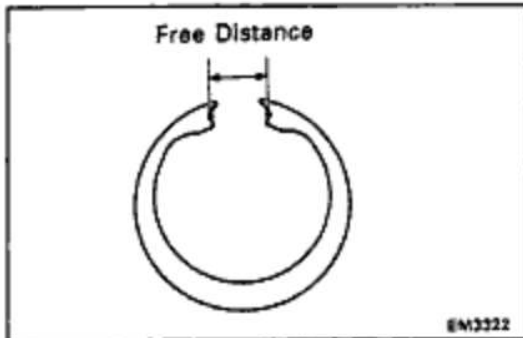

#### E. Inspect camshaft gear spring

Using a vernier caliper, measure the free distance between the spring ends.

**Free distance:**

**22.5 – 22.9 mm (0.886 – 0.902 in.)**

If the free distance is not as specified, replace the gear spring.

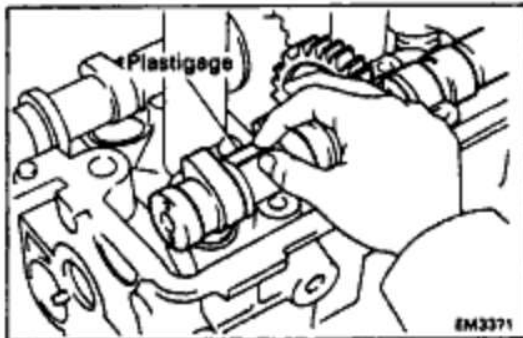

#### F. Inspect camshaft journal oil clearance

- (a) Clean the bearing caps and camshaft journals.
- (b) Place the camshafts on the cylinder head.
- (c) Lay a strip of Plastigage across each of the camshaft journals.

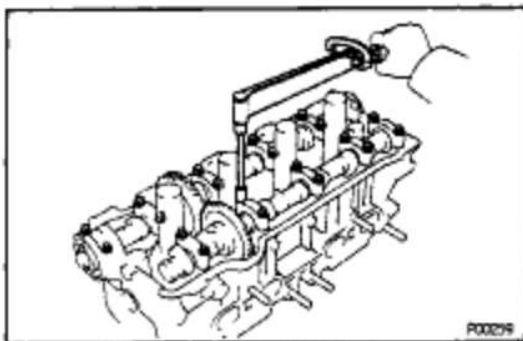

- (d) Install the bearing caps.

(See step 4 on pages [EG1-69](#) to 71)

**Torque: 19 N-m (190 kgf-cm, 14 ft-lbf)**

**NOTICE: Do not turn the camshaft.**

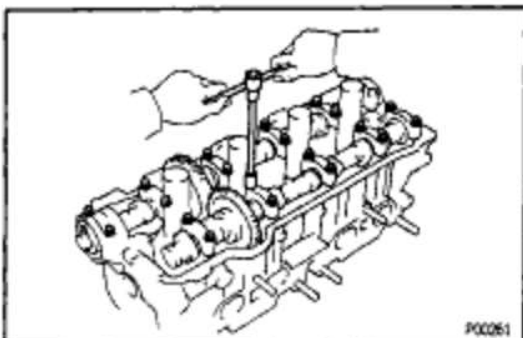

- (e) Remove the bearing caps.

## EG1-64

## 5S-FE ENGINE - ENGINE MECHANICAL

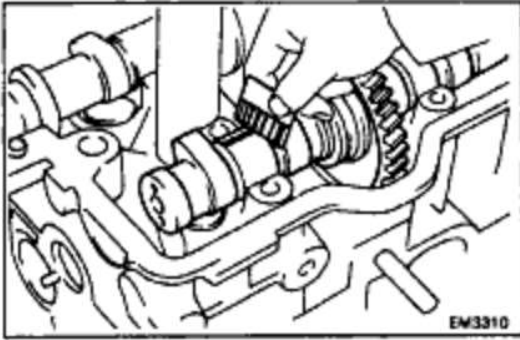

(f) Measure the Plastigage at its widest point.

**Standard oil clearance:**

**0.025 – 0.062 mm (0.0010 – 0.0024 in.)**

**Maximum oil clearance:**

**0.10 mm (0.0039 in.)**

If the oil clearance is greater than maximum, replace the camshaft. If necessary, replace the bearing caps and cylinder head as a set.

(g) Completely remove the Plastigage.

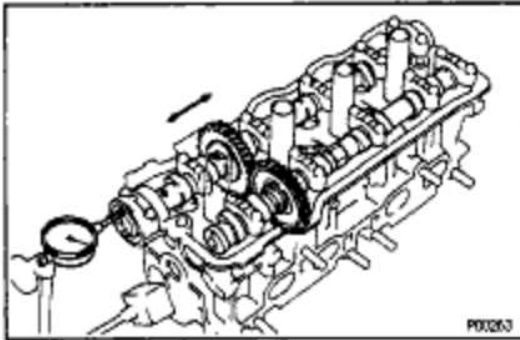

### G. Inspect camshaft thrust clearance

(a) Install the camshaft.

(See step 4 on pages [EG1-69](#) to 71)

(b) Using a dial indicator, measure the thrust clearance while moving the camshaft back and forth.

**Standard thrust clearance:**

**Intake**

**0.045 – 0.100 mm (0.0018 – 0.0039 in.)**

**Exhaust**

**0.030 – 0.085 mm (0.0012 – 0.0033 in.)**

**Maximum thrust clearance:**

**Intake**

**0.12 mm (0.0047 in.)**

**Exhaust**

**0.10 mm (0.0039 in.)**

If the thrust clearance is greater than maximum, replace the camshaft. If necessary, replace the bearing caps and cylinder head as a set.

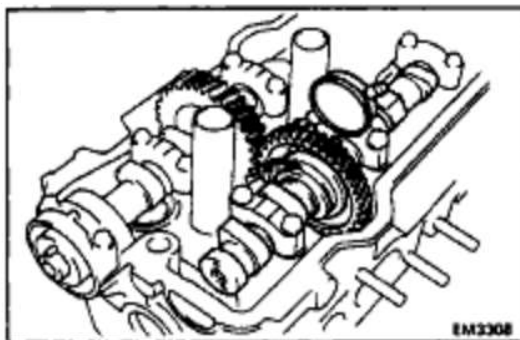

### H. Inspect camshaft gear backlash

(a) Install the camshafts without installing the exhaust cam sub gear.

(See step 4 on pages [EG1-69](#) to 71)

(b) Using a dial indicator, measure the backlash.

**Standard backlash:**

**0.020 – 0.200 mm (0.0008 – 0.0079 in.)**

**Maximum backlash:**

**6.30 mm (0.0188 in.)**

If the backlash is greater than maximum, replace the camshafts.



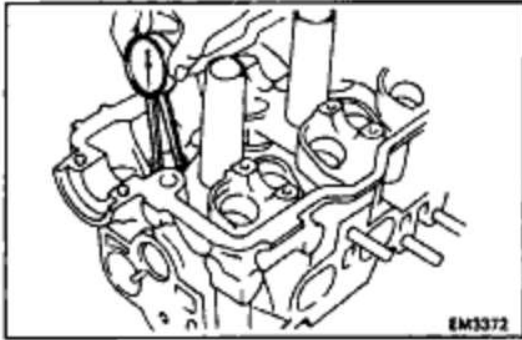

## 11. INSPECT VALVE LIFTERS AND LIFTER BORES

- (a) Using a caliper gauge, measure the lifter bore diameter of the cylinder head.

**Lifter bore diameter:**

**31.000 – 31.018 mm (1.2205 – 1.2213 in.)**

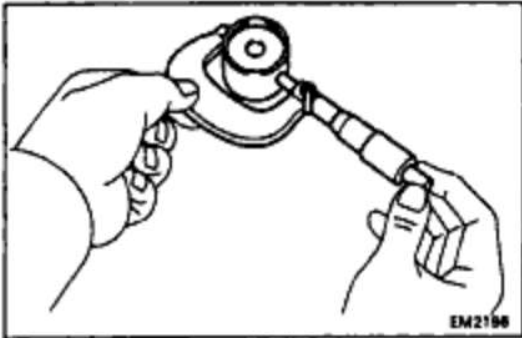

- (b) Using a micrometer, measure the lifter diameter.

**Lifter diameter:**

**30.966 – 30.976 mm (1.2191 – 1.2195 in.)**

- (c) Subtract the lifter diameter measurement from the lifter bore diameter measurement.

**Standard oil clearance:**

**0.024 – 0.052 mm (0.0009 – 0.0020 in.)**

**Maximum oil clearance:**

**0.07 mm (0.0028 in.)**

If the oil clearance is greater than maximum, replace the lifter. If necessary, replace the cylinder head.

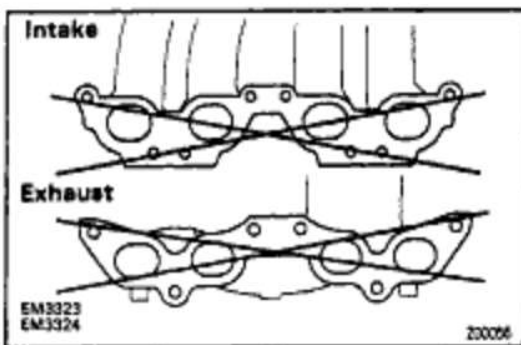

## 12. INSPECT MANIFOLDS

Using a precision straight edge and feeler gauge, measure the surface contacting the cylinder head for warpage.

**Maximum warpage:**

**0.30 mm (0.0118 in.)**

If warpage is greater than maximum, replace the manifold.

## EG1-66

## 5S-FE ENGINE - ENGINE MECHANICAL

**CYLINDER HEAD ASSEMBLY****(See Components for Removal and Installation)**

HINT:

- Thoroughly clean all parts to be assembled.  
Before installing the parts, apply new engine oil to all sliding and rotating surfaces.
- Replace all gaskets and oil seals with new ones.

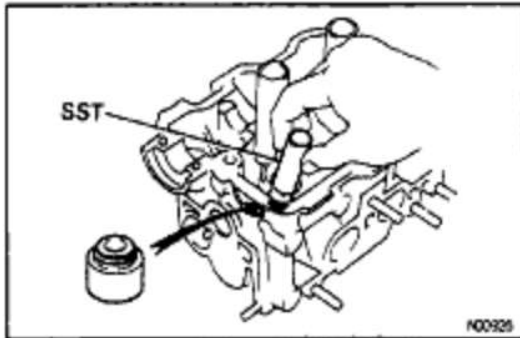
**1. INSTALL VALVES**

- (a) Using SST, push in a new oil seal.  
SST 09201 -41020

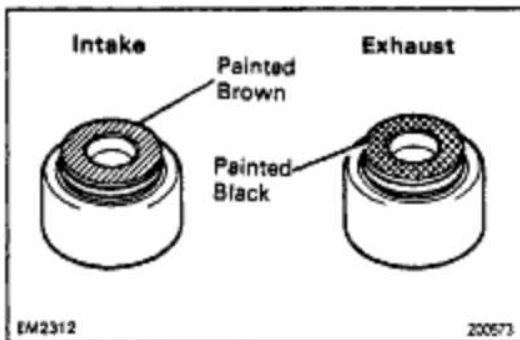

HINT: The intake valve oil seal is brown and the exhaust valve oil seal is black.

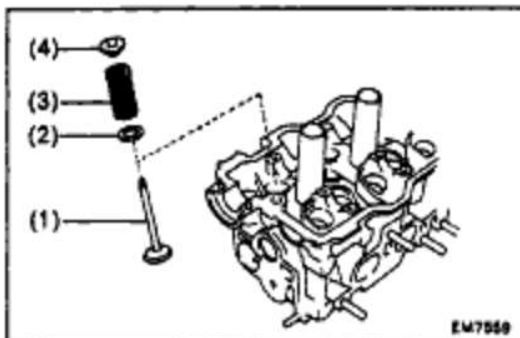

- (b) Install the following parts:

- (1) Valve
- (2) Spring seat
- (3) Valve spring
- (4) Spring retainer

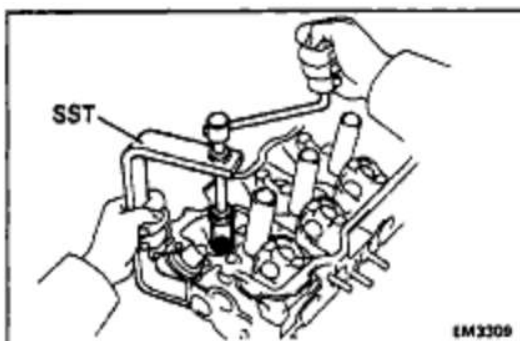

- (c) Using SST, compress the valve spring and place the 2 keepers around the valve stem.  
SST 09202 - 70010

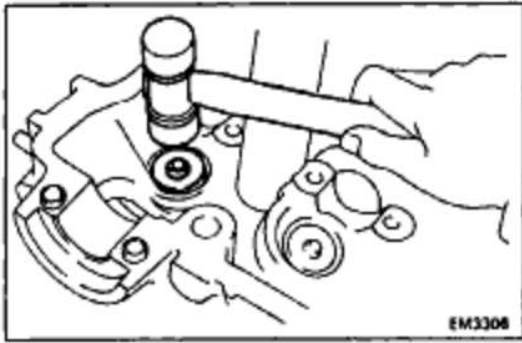

- (d) Using a plastic-faced hammer, lightly tap the valve stem tip to assure proper fit.

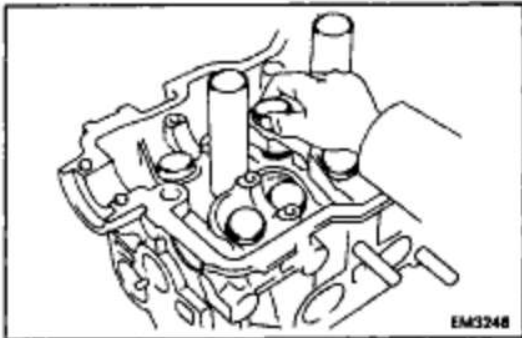

## 2. INSTALL VALVE LIFTERS AND SHIMS

- (a) Install the valve lifter and shim.
- (b) Check that the valve lifter rotates smoothly by hand.

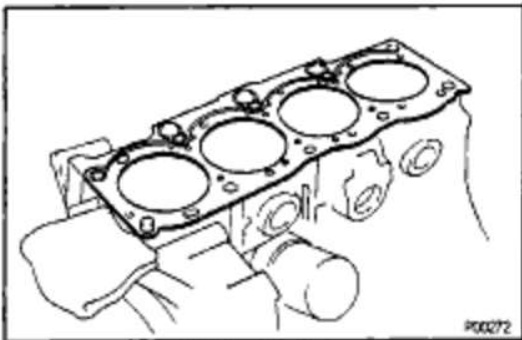

## CYLINDER HEAD INSTALLATION

(See Components for Removal and Installation)

### 1. INSTALL CYLINDER HEAD

#### A. Place cylinder head on cylinder block

- (a) Place a new cylinder head gasket in position on the cylinder block.

**NOTICE:** Be careful of the installation direction.

- (b) Place the cylinder head in position on the cylinder head gasket.

#### B. Install cylinder head bolts

HINT:

- The cylinder head bolts are tightened in 2 progressive steps (steps (b) and (d)).
- If any cylinder head bolt is broken or deformed, replace it.
  - (a) Apply a light coat of engine oil on the threads and under the heads of the cylinder head bolts.
  - (b) Using SST, install and uniformly tighten the 10 cylinder head bolts and plate washers in several passes, in the sequence shown.

SST 09011- 38121

**Torque: 49 N-m (500 kgf-cm, 36 ft-lbf)**

If any one of the cylinder head bolts does not meet the torque specification, replace the cylinder head bolt.

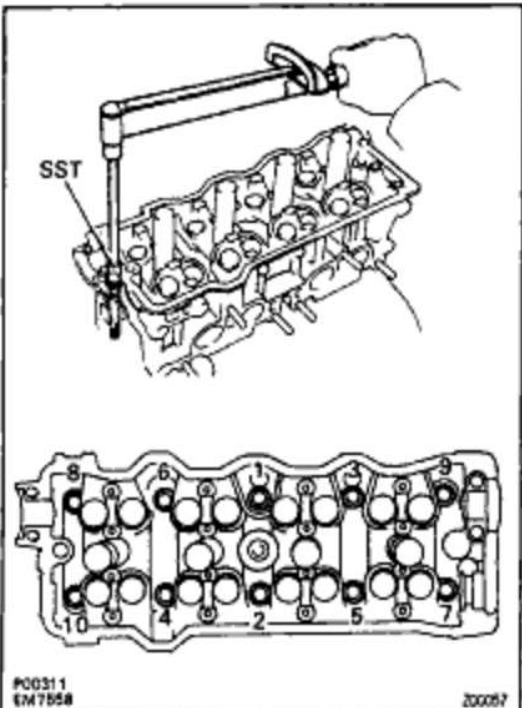

## EG1-68

## 5S-FE ENGINE - ENGINE MECHANICAL

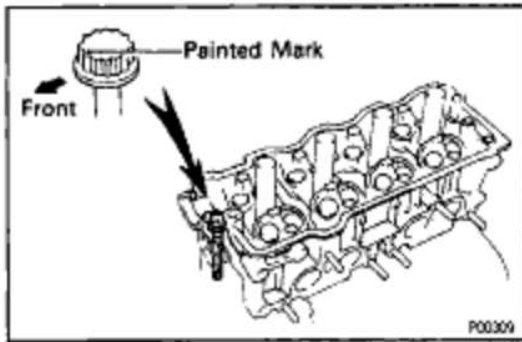

- (c) Mark the front of the cylinder head bolt head with paint.

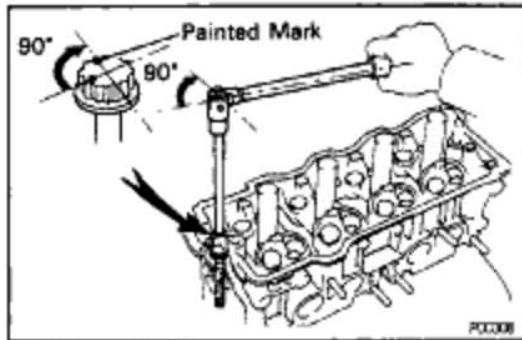

- (d) Retighten the cylinder head bolts 90° in the sequence shown on the previous page.  
 (e) Check that the painted mark is now at a 90° angle to front.

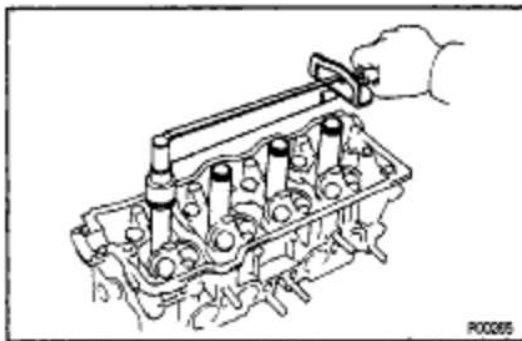

## 2. INSTALL SPARK PLUG TUBES

- (a) Clean the cylinder head tube holes of any residual adhesive, oil or foreign particles. Remove any oil with kerosene or gasoline.  
 (b) Screw the threads of the spark plug tube coated with adhesive into the cylinder head.  
 (c) Using the spark plug tube nut and a 30 mm socket wrench, tighten the spark plug tubes.

**Torque: 39 N-m (400 kgf-cm, 29 ft-lbf)**



## 3. ASSEMBLY EXHAUST CAMSHAFT

- (a) Mount the hexagon wrench head portion of the camshaft in a vise.

**NOTICE: Be careful not to damage the camshaft.**

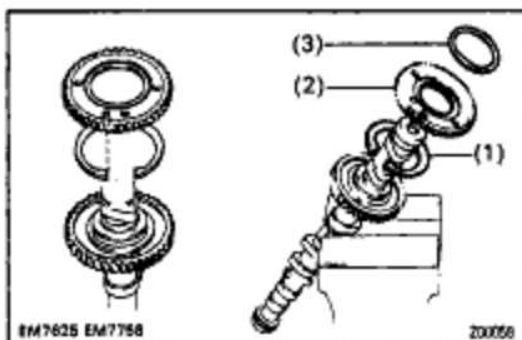

- (b) Install the following parts:

- (1) Camshaft gear spring
- (2) Camshaft sub gear
- (3) Wave washer

**HINT:** Align the pins on the gears with the spring ends.

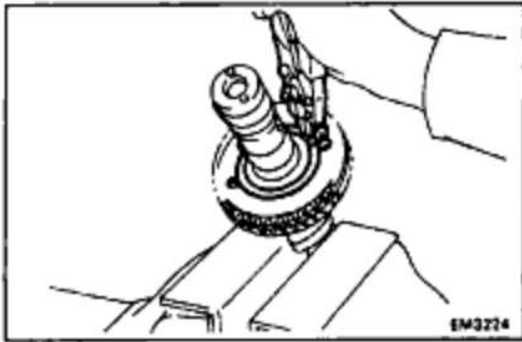

(c) Using snap ring pliers, install the snap ring.

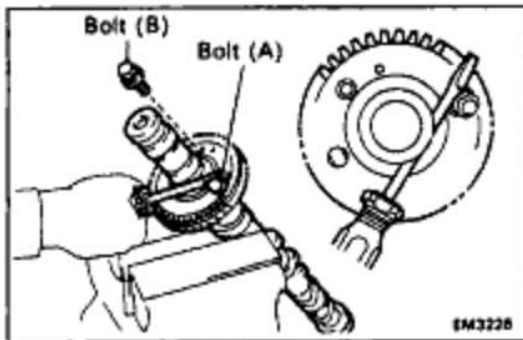

(d) Insert a service bolt (A) into the service hole of the camshaft sub gear.

(e) Using a screwdriver, align the holes of the camshaft main gear and sub gear by turning camshaft sub gear clockwise, and install a service bolt (13).

**NOTICE:** Be careful not to damage the camshaft.

#### 4. INSTALL CAMSHAFTS

**NOTICE:** Since the thrust clearance of the camshaft is small, the camshaft must be kept level while it is being installed. If the camshaft is not kept level, the portion of the cylinder head receiving the shaft thrust may crack or be damaged, causing the camshaft to seize or break. To avoid this, the following steps should be carried out.

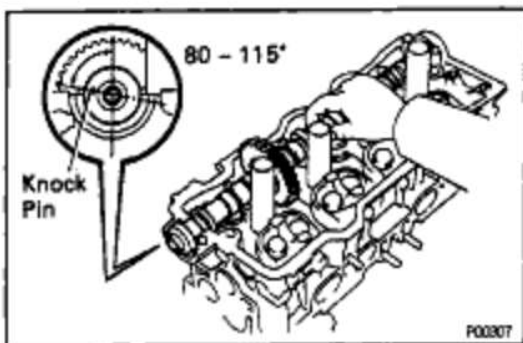

##### A. Install intake camshaft

(a) Apply MP grease to the thrust portion of the camshaft.

(b) Place the intake camshaft at 80–115° BTDC of camshaft angle, on the cylinder head.

**HINT:** The above angle arrows the No.1 and No.3 cylinder cam lobes of the intake camshaft to push their valve lifters evenly.

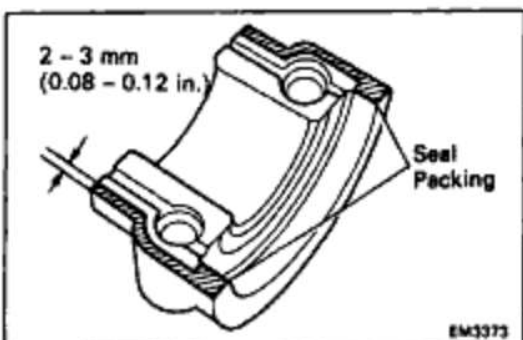

(c) Apply seal packing to the No. 1 bearing cap as shown.

**Seal packing:**

**Part No.08826 -00080 or equivalent**

## EG1-70

## 5S-FE ENGINE - ENGINE MECHANICAL

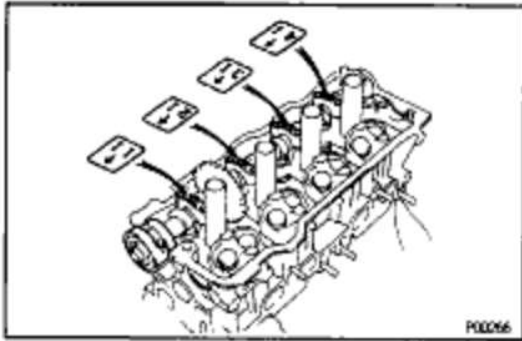

(d) Install the bearing caps in their proper locations.

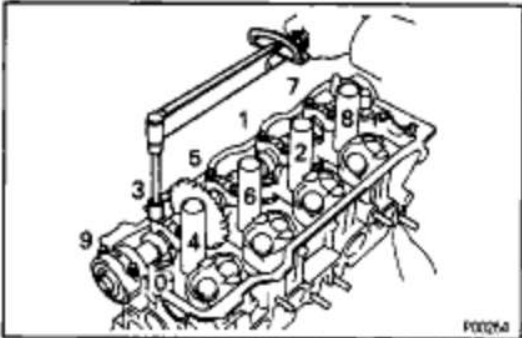

(e) Apply a light coat of engine oil on the threads and under the heads of the bearing cap bolts.

(f) Install and uniformly tighten the 10 bearing cap bolts in several passes, in the sequence shown.

**Torque: 19 N-m (190 kgf-cm, 14 ft-lbf)**

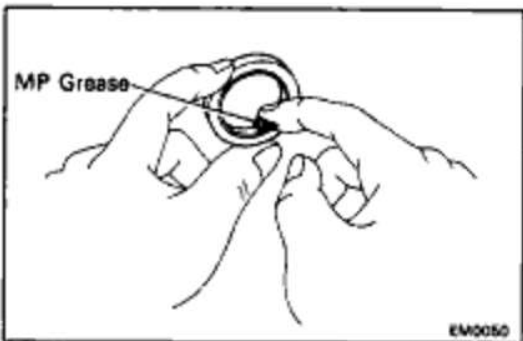

(g) Apply MP grease to a new oil seal lip.

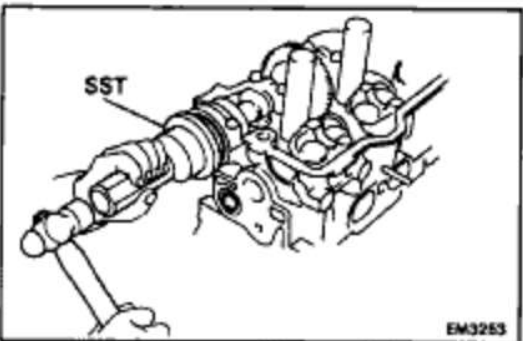

(h) Using SST, tap in the oil seal.

SST 09223-4601 1

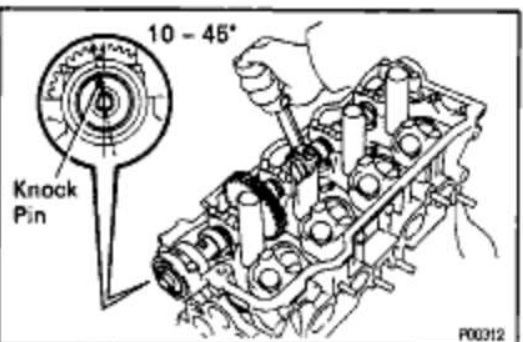

### B. Install exhaust camshaft

(a) Set the knock pin of the intake camshaft at 10-45° BTDC of camshaft angle.

HINT: The above angle allows the No.2 and No.4 cylinder cam lobes of the exhaust camshaft to push their valve lifters evenly.

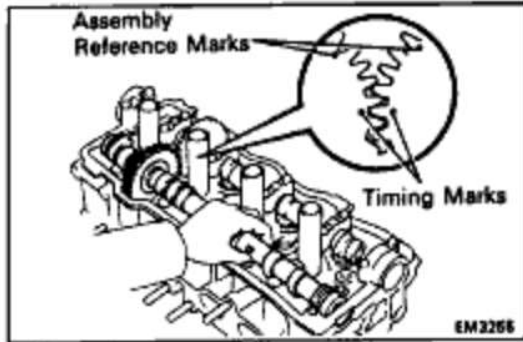

- (b) Apply MP grease to the thrust portion of the camshaft.
- (c) Engage the exhaust camshaft gear to the intake camshaft gear by matching the timing marks on each gear.
- (d) Roll down the exhaust camshaft onto the bearing journals while engaging gears with each other.  
**NOTICE: There are also assembly reference marks on each gear as shown in the illustration. Do not use these marks.**

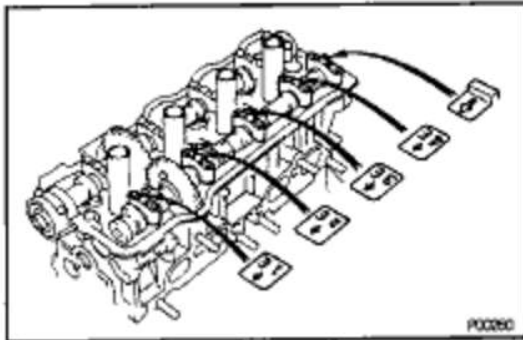

- (e) Turn the intake camshaft clockwise or counterclockwise little by little until the exhaust camshaft sits in the bearing journals evenly without rocking the camshaft on the bearing journals.  
**NOTICE: It is very important to replace the camshaft in the bearing journals evenly while tightening bearing caps in the subsequent steps.**
- (f) Install the bearing caps in their proper locations.

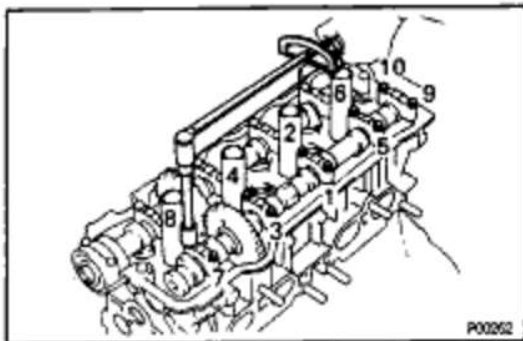

- (g) Apply a light coat of engine oil on the threads and under the heads of the bearing cap bolts.
- (h) Install and uniformly tighten the 10 bearing cap bolts in several passes, in the sequence shown.  
**Torque: 19 N-m (190 kgf-cm, 14 ft-lbf)**

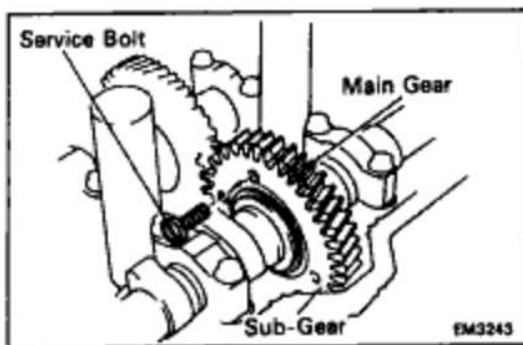

- (i) Remove the service bolt (B).

## 5. CHECK AND ADJUST VALVE CLEARANCE

(See page [EG1-12](#))

Turn the camshaft and position the cam lobe upward, and check and adjust the valve clearance.

**Valve clearance (Cold):**

**Intake**

0.19 – 0.29 mm (0.007 – 0.011 In.)

**Exhaust**

0.28 – 0.38 mm (0.011 – 0.015 In.)

## EG1-72

## 5S-FE ENGINE - ENGINE MECHANICAL

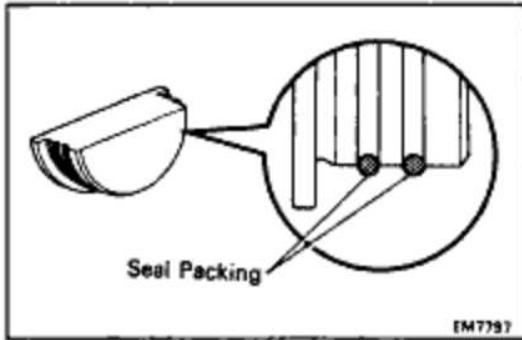
**6. INSTALL SEMI-CIRCULAR PLUGS**

- (a) Remove any old packing (FIGP) material.
- (b) Apply seal packing to the semi-circular plug grooves.

**Seal packing:**

**Part No.08826-00080 or equivalent**

- (c) Install the 2 semi-circular plugs to the cylinder head.

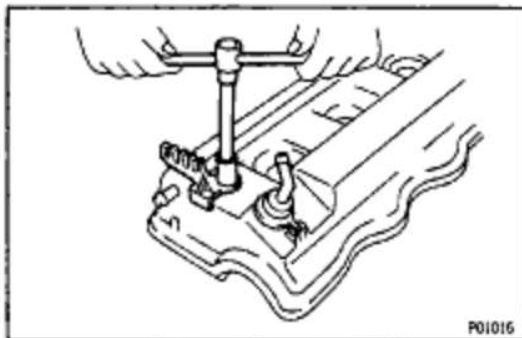
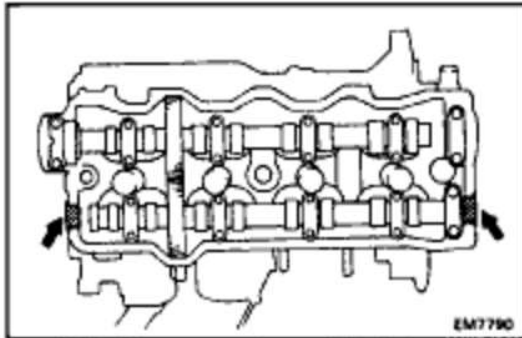
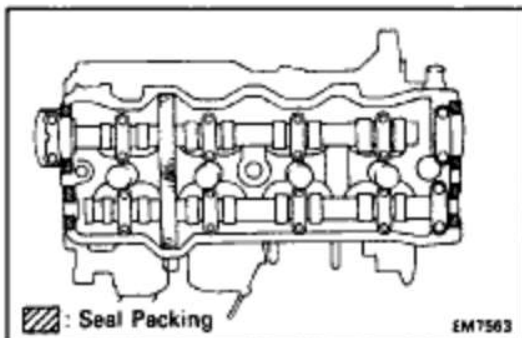
**7. INSTALL PCV VALVE AND HIGH-TENSION CORDS CLAMP****8. INSTALL CYLINDER HEAD COVER**

- (a) Remove any old packing (FIGP) material.
- (b) Apply seal packing to the cylinder head as shown in the illustration.

**Seal packing:**

**Part No.08826-00080 or equivalent**



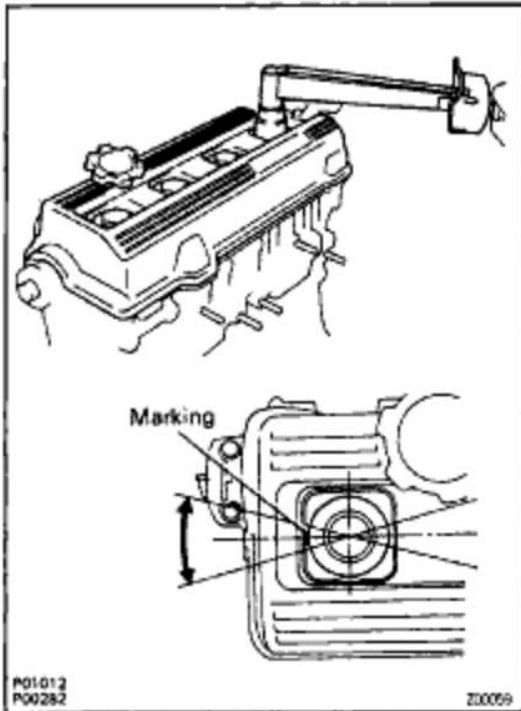

(c) Install the gasket to the head cover.

(d) Install the head cover with the 4 grommets and nuts.

Uniformly tighten the nuts in several passes.

**Torque: 23 N-m (230 kgf-cm, 17 ft-lbf)**

HINT: Install the grommets so that their markings are as shown in the illustration.

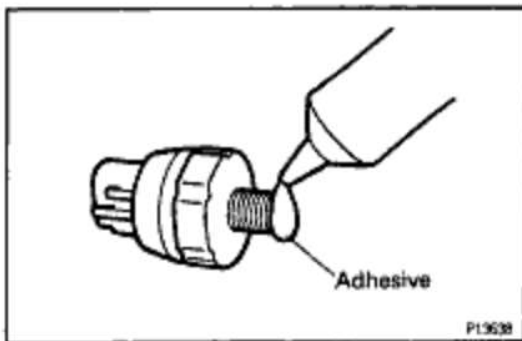

### 9. INSTALL OIL PRESSURE SWITCH

Apply adhesive to 2 or 3 threads.

Adhesive:

Part No.08833-00080, THREE BOND 1324 or equivalent

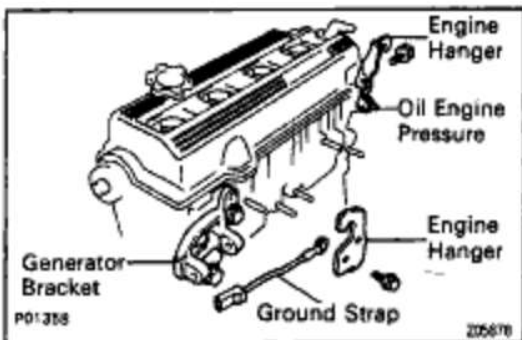

### 10. INSTALL GENERATOR BRACKET

Install the generator bracket with the 3 bolts.

**Torque: 42 N-m (425 kgf-cm, 31 ft-lbf)**

### 11. INSTALL ENGINE HANGERS

Install the engine hanger with the bolt. Install the 2 engine hangers. Install the ground strap.

**Torque: 25 N-m (250 kgf-cm, 18 ft-lbf)**

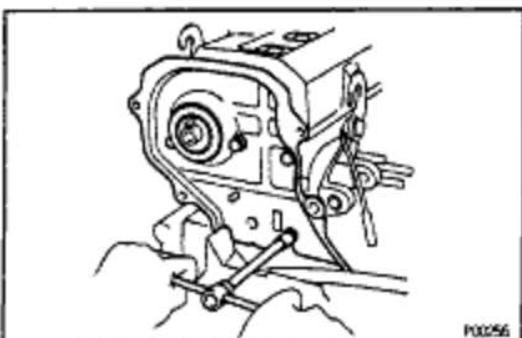

### 12. INSTALL NO.3 TIMING BELT COVER

Install the timing belt cover with the 4 bolts.

**Torque: 7.8 N-m (80 kgf-cm, 69 in-lbf)**

## EG1-74

## 5S-FE ENGINE - ENGINE MECHANICAL

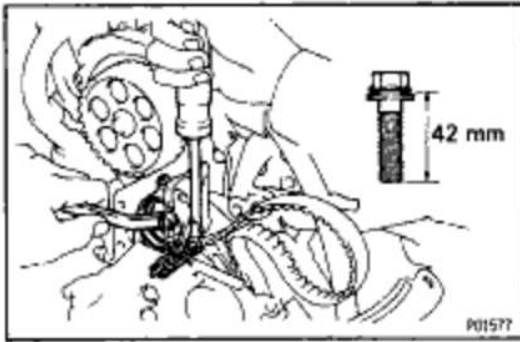

### 13. TEMPORARILY INSTALL NO.1 IDLER PULLEY AND TENSION SPRING

- (a) Install the pulley with the bolt. Do not tighten the bolt yet.

HINT: Use bolt 42 mm (1.65 in.) in length.

- (b) Install the tension spring.  
 (c) Pry the pulley toward the left as far as it will go and tighten the bolt.  
 (d) Check that the idler pulley moves smoothly.

### 14. INSTALL CAMSHAFT TIMING PULLEY AND TIMING BELT

(See page [EG1-33](#))

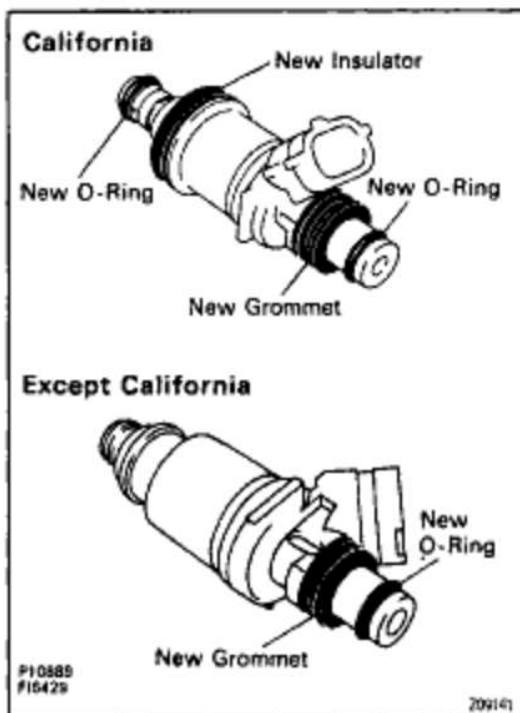

### 15. INSTALL INJECTORS AND DELIVERY PIPE

- (a) California:  
Install new insulator and grommet to each injector.
- (b) Except California:  
Install a new grommet to each injector.
- (c) California:  
Apply a light coat of gasoline to 2 new 0-rings, and install them to each injector.
- (d) Except California:  
Apply a light coat of gasoline to a new 0-ring, and install it to each injector.

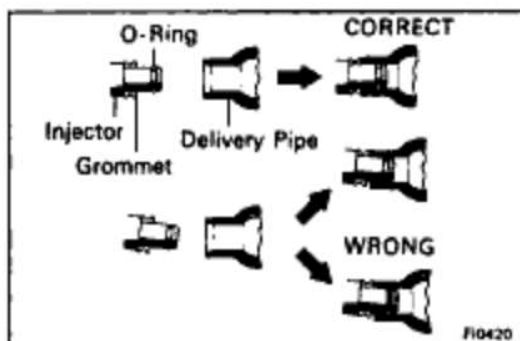

- (e) While turning the injector left and right, install it to the delivery pipes. Install the 4 injectors.

## 5S-FE ENGINE - ENGINE MECHANICAL

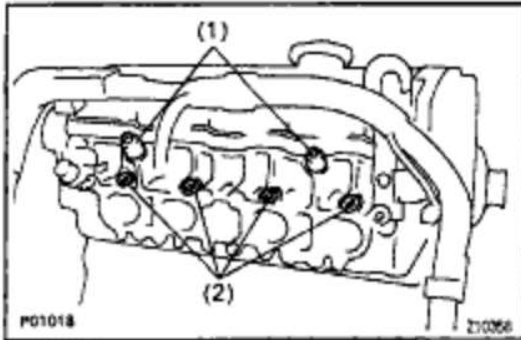

- (f) Install the following parts to the intake manifold:
- (1) 2 spacers
  - (2) Except California:  
4 new insulators

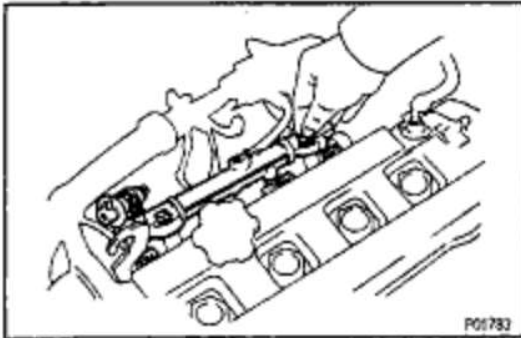

- (g) Place the 4 injectors together with the delivery pipe in position on the cylinder head.
- (h) Temporarily install the 2 bolts holding the delivery pipe to the cylinder head.

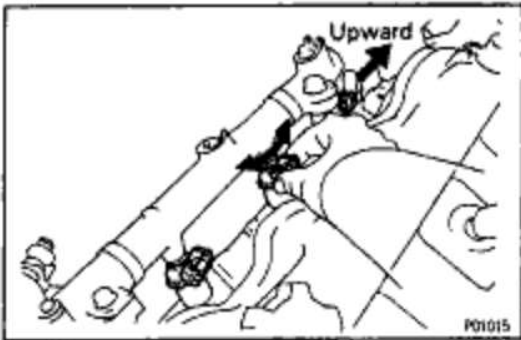

- (i) Check that the injectors rotate smoothly.  
HINT: If injectors do not rotate smoothly, the probable cause is incorrect installation of O-rings. Replace the O-rings.
- (j) Position the injector connector upward.

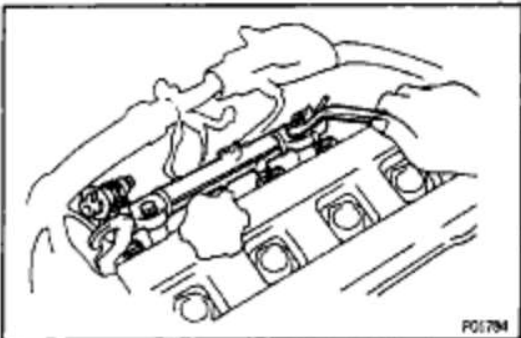

- (k) Tighten the 2 bolts holding the delivery pipe to the cylinder head.  
**Torque: 13 N-m (130 kgf-cm, 9 ft-lbf)**

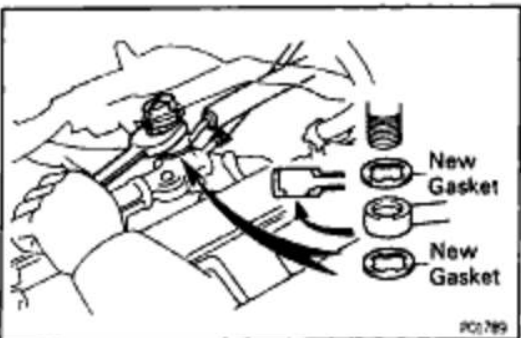

- (l) Connect the fuel return hose.
- (m) Connect the fuel inlet pipe to the delivery pipe with 2 new gaskets and the pulsation damper.  
**Torque: 34 N-m (350 kgf-cm, 25 ft-lbf)**

## EG1-76

## 5S-FE ENGINE - ENGINE MECHANICAL

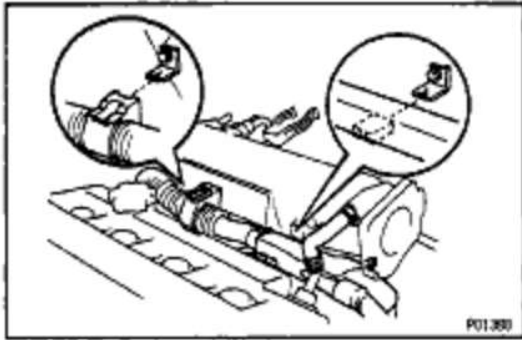
**16. INSTALL INTAKE MANIFOLD**

- (a) Connect the 2 wire clamps to the wire brackets on the intake manifold.

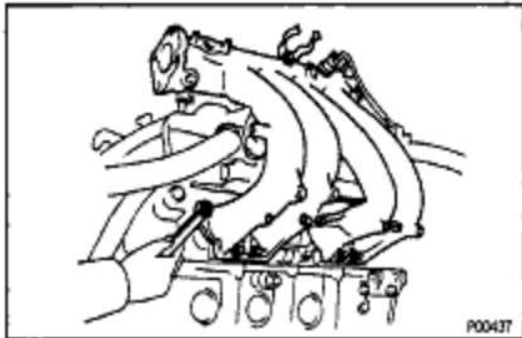

- (b) Install a new gasket and the intake manifold with the 6 bolts and 2 nuts. Uniformly tighten the bolts and nuts in several passes.

**Torque: 19 N-m (195 kgf-cm, 14 ft-lbf)**

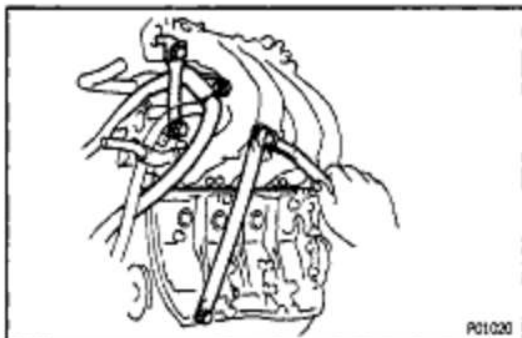

- (c) Install the vacuum hose bracket and engine wire harness with the bolt.

- (d) Install the No.1 air intake chamber and manifold stays, wire bracket with the 4 bolts.

14 mm head bolt

**Torque: 42 N-m (425 kgf-cm, 31 ft-lbf)**

12 mm head bolt

**Torque: 22 N-m (220 kgf-cm, 16 ft-lbf)**

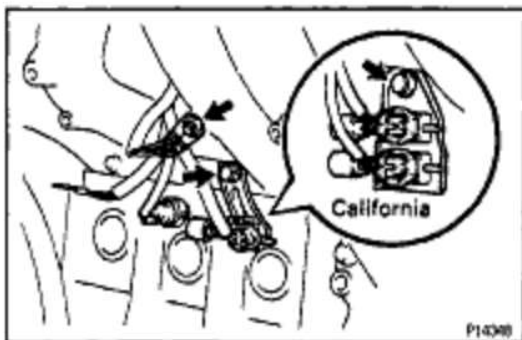
**17. INSTALL VSV OR VSV ASSEMBLY****18. CALIFORNIA ONLY:**

**CONNECT VSV (FOR FUEL PRESSURE CONTROL) CONNECTOR**

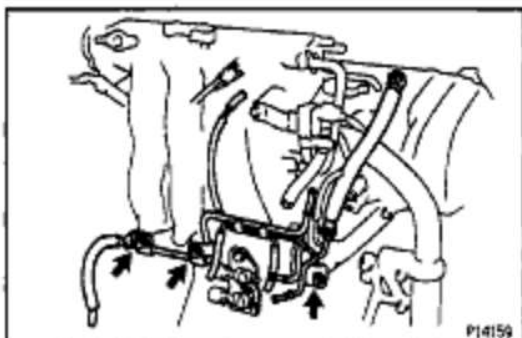
**19. CONNECT KNOCK SENSOR AND VSV (FOR EGR) CONNECTORS****20. INSTALL 2 ENGINE WIRE GROUND STRAPS TO INTAKE MANIFOLD****21. CALIFORNIA:  
INSTALL AIR TUBE**

- (a) Install the air tube and wire clamp with the 3 bolts.

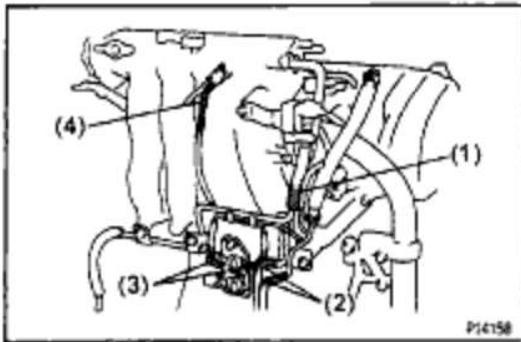

(b) Connect the following hoses:

- (1) w/ A/C:  
A/C hose (from ASV) to air tube
- (2) 2 air hoses (from PS pump) to air tube
- (3) 2 vacuum hoses to VSV (for fuel pressure control)
- (4) Vacuum hose to air intake chamber

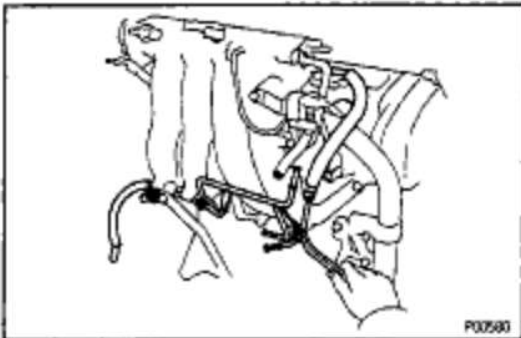

## 22. EXCEPT CALIFORNIA: INSTALL AIR TUBE

(a) Install the air tube and wire clamp with the 3 bolts.

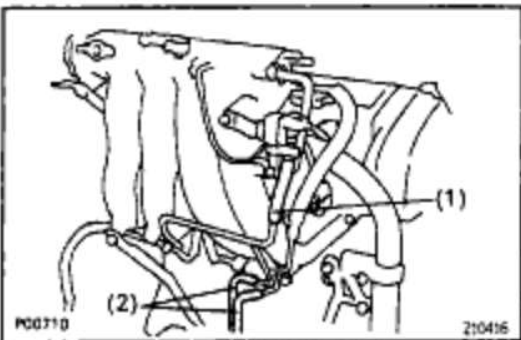

(b) Connect the following hoses to the air tube:

- (1) w/ A/C:  
Air hose from ASV
- (2) 2 air hose from PS pump

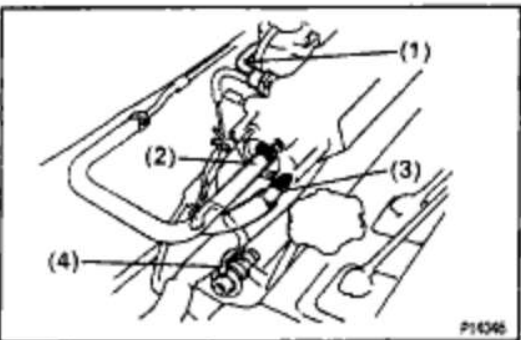

## 23. CONNECT VACUUM HOSES

Connect the following hoses:

- (1) MAP sensor hose to air intake chamber
- (2) Brake booster vacuum hose to air intake chamber
- (3) PS vacuum hose to air intake chamber
- (4) Vacuum sensing hose to fuel pressure regulator.

## 24. w/ A/C:

### CONNECT A/C IDLE-UP VALVE CONNECTOR

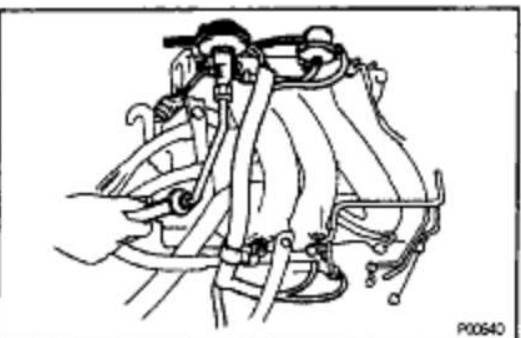

## 25. INSTALL EGR VALVE AND VACUUM MODULATOR

(a) Install a new gasket and the EGR valve with the union nut and 2 nuts.

Union nut:

**Torque: 59 N-m (600 kgf-cm, 43 ft-lbf)**

**Nut:**

**Torque: 13 N-m (130 kgf-cm, 9 ft-lbf)**

(b) Install the EGR modulator to the clamp.

## EG1-78

## 5S-FE ENGINE - ENGINE MECHANICAL

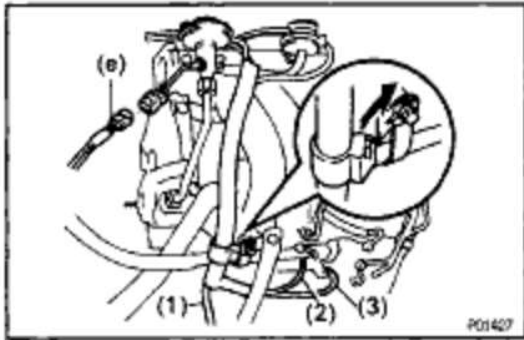

- (c) Connect the vacuum hose clamp.
- (d) Connect the following hoses:
  - (1) Vacuum hose to charcoal canister
  - (2) Vacuum hose (from EGR valve) to E port of VSV (for EGR)
  - (3) Vacuum hose (from Q port of EGR vacuum modulator) to G port of VSV (for EGR)
- (e) Connect the EGR gas temperature sensor connector.

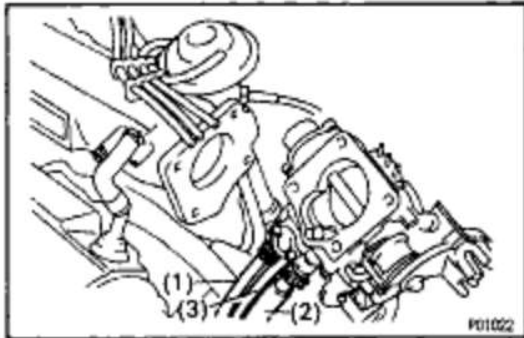
**26. INSTALL THROTTLE BODY**

- (a) Connect the following hoses to the throttle body:
  - (1) Water bypass hose from water outlet
  - (2) Water bypass hose from water bypass pipe
  - (3) California:
    - Air hose from cylinder head
  - Except California:
    - Air hose from air tube

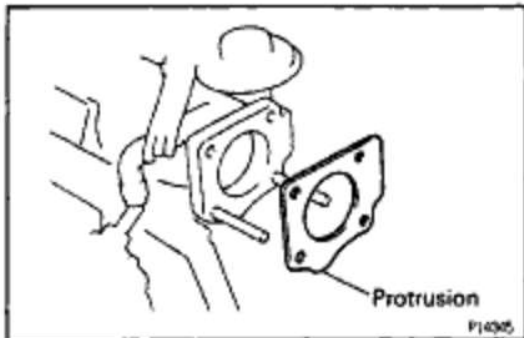

- (b) Place a new gasket on the intake chamber, facing the protrusion downward.

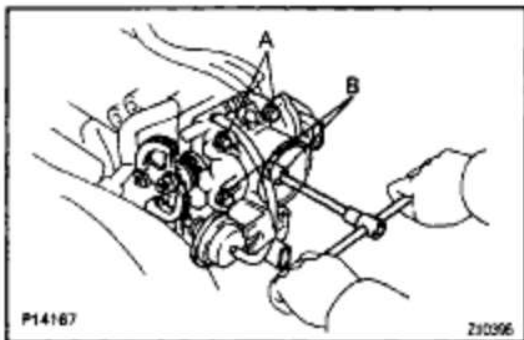

- (c) Type A:
  - Install the throttle body with the 4 bolts.
  - Torque: 19 N-m (195 kgf-cm, 14 ft-lbf)**
  - HINT: Each bolt is indicated in the illustration.
  - Bolt length:
    - A 45 mm (1.77 in.)
    - B 55 mm (2.17 in.)

- (d) Type e:
  - Install the throttle body with the 2 bolts and 2 nuts.
  - Torque: 19 N-m (195 kgf-cm, 14 ft-lbf)**

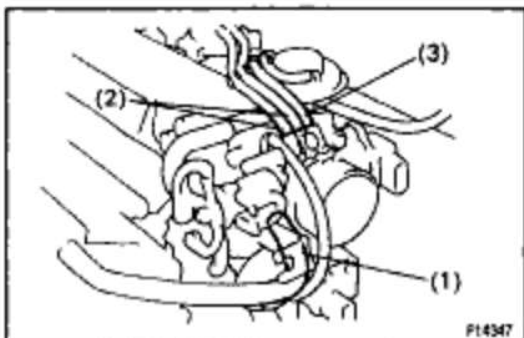

- (e) Connect the following hoses to the throttle body:
  - (1) PCV hose
  - (2) 2 vacuum hoses from EGR vacuum modulator
  - (3) Vacuum hose from TVV (for EVAP)

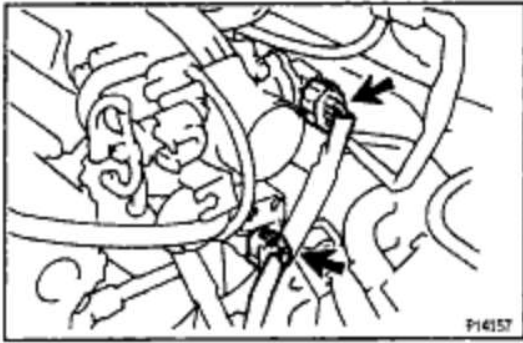

- (f) Connect the IAC valve connector.  
 (g) Connect the throttle position sensor connector.

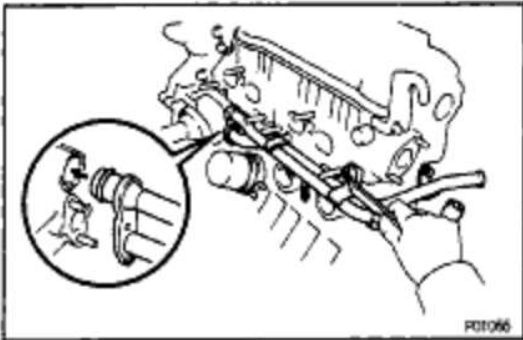

## 27. INSTALL WATER BYPASS PIPE

- (a) Install a new O-ring to the bypass pipe.  
 (b) Apply soapy water on the O-ring.  
 (c) Install a new gasket and the bypass pipe with the 2 nuts and 2 bolts.

**Torque (Nut): 8.8 N-m (90 kgf-cm, 78 in.-lbf)**

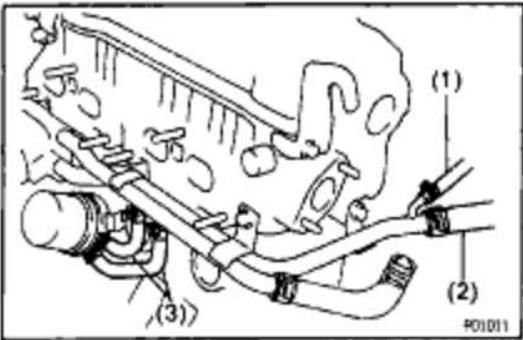

- (d) Connect the following hoses:  
 (1) IAC water bypass hose  
 (2) Heater water hose  
 (3) w/ Oil Cooler:  
 2 oil cooler water bypass hoses



## 28. INSTALL WATER OUTLET

- (a) Install a new gasket and the water outlet with the 2 bolts.

**Torque: 15 N-m (150 kgf-cm, 11 ft-lbf)**

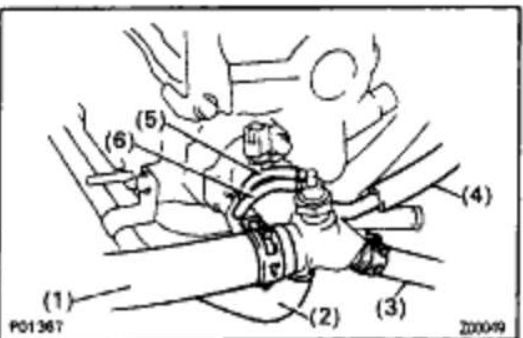

- (b) Connect the following hoses:  
 (1) Upper radiator hose  
 (2) Water bypass pipe hose  
 (3) Heater water hose  
 (4) IAC water bypass hose  
 (5) TVV (for EVAP) vacuum hose (from P port of throttle body)  
 (6) TVV (for EVAP) vacuum hose (from charcoal canister)

## EG1-80

## 5S-FE ENGINE - ENGINE MECHANICAL

(c) Connect the following connectors:

- (1) Engine coolant temperature sender gauge connector
- (2) Engine coolant temperature sensor connector

### 29. CONNECT ENGINE WIRE (FOR OXYGEN SENSORS) TO ENGINE HANGER

### 30. CONNECT OIL PRESSURE SWITCH CONNECTOR

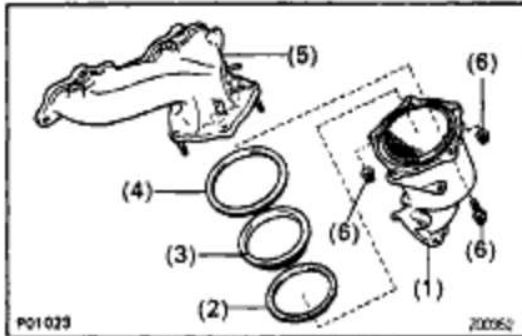

### 31. ASSEMBLE EXHAUST MANIFOLD AND WARM UP THREE-WAY CATALYTIC CONVERTER

Assemble the following parts:

- (1) WU-TWC
- (2) Cushion
- (3) Retainer
- (4) Gasket
- (5) Exhaust manifold
- (6) 3 bolts and 2 nuts

Torque: 29 N-m (300 kgf-cm, 22 ft-lbf)

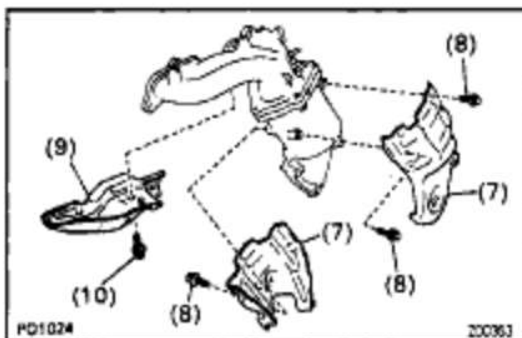
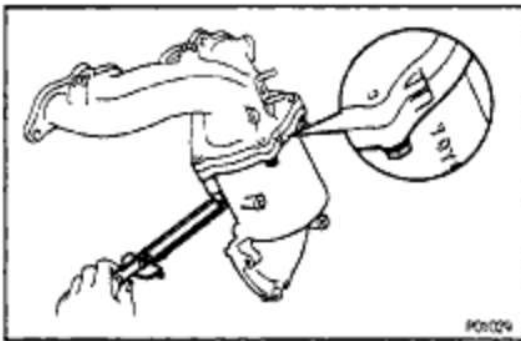

- (7) 2 converter heat insulators
- (8) 8 bolts
- (9) Manifold lower heat insulator
- (10) 3 bolts

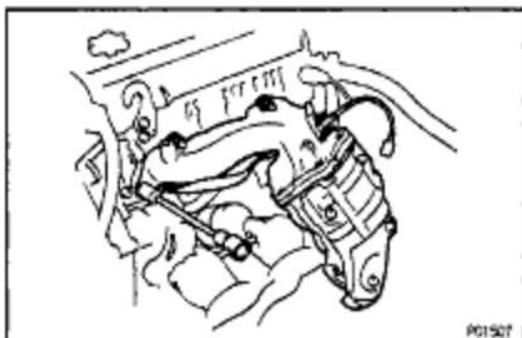

### 32. INSTALL EXHAUST MANIFOLD AND WARM UP THREE-WAY CATALYTIC CONVERTER ASSEMBLY

- (a) Install a new gasket, the exhaust manifold and WU-TWC assembly with the 6 nuts. Uniformly tighten the nuts in several passes.

Torque: 49 N-m (540 kgf-cm, 36 ft-lbf)



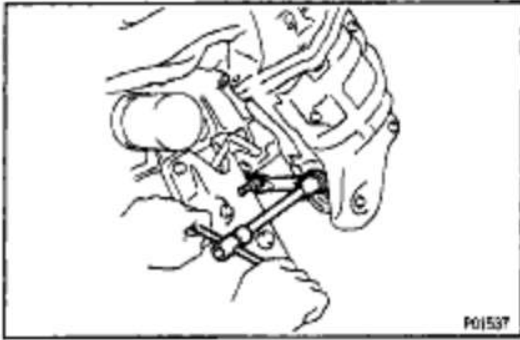

- (b) Install the manifold stay with the bolt and nut.  
**Torque: 42 N-m (425 kgf-cm, 31 ft-lbf)**

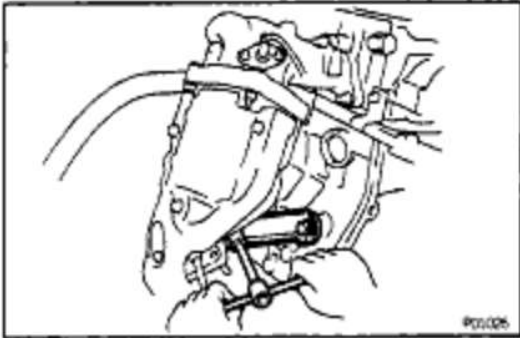

- (c) Install the No. 1 manifold stay with the bolt and nut.  
**Torque: 42 N-m (425 kgf-cm, 31 ft-lbf)**

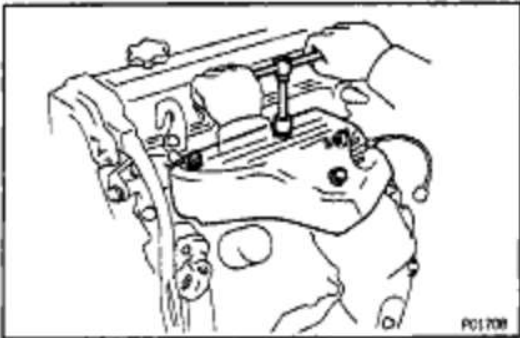

- (d) Install the manifold upper heat insulator with the 4 bolts.  
 (e) Connect the main oxygen and sub oxygen sensor connectors.

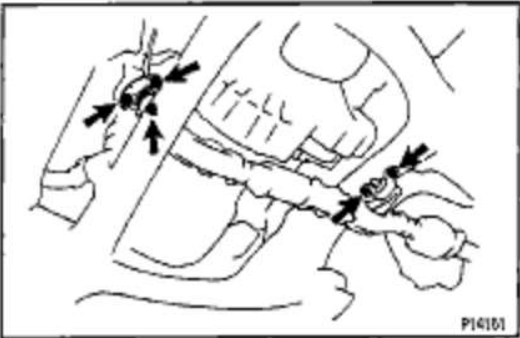

### 33. CONNECT FRONT EXHAUST PIPE

- (a) Place a new gasket on the front exhaust pipe.  
 (b) Using a 14 mm deep socket wrench, install the 3 new nuts holding the front exhaust pipe to the WU -TWC.  
**Torque: 62 N-m (630 kgf-cm, 46 ft-lbf)**  
 (c) Install the bracket with the 2 bolts.

### 34. INSTALL DISTRIBUTOR

(See page [IG-17](#) and [37](#))

### 35. INSTALL GENERATOR (See page [CH-24](#))

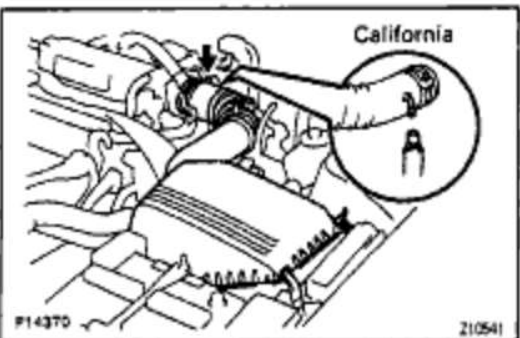

### 36. INSTALL AIR CLEANER CAP, RESONATOR AND AIR CLEANER HOSE

- (a) Connect the air cleaner hose to the throttle body.  
 (b) Install the air cleaner cap together with the resonator and air cleaner hose.  
 (c) California only:  
 Connect the air hose to the air cleaner hose.  
 (d) Connect the intake air temperature sensor connector.

**37. A/T:****CONNECT AND ADJUST THROTTLE CABLE****38. CONNECT AND ADJUST ACCELERATOR CABLE****39. FILL WITH ENGINE COOLANT**

Capacity:

6.3 liters (6.7 US qts, 5.5 Imp. qts)

**40. CONNECT NEGATIVE (-) TERMINAL CABLE TO BATTERY****41. START ENGINE AND CHECK FOR LEAKS****42. ADJUST IGNITION TIMING**

(See page IG -19 and 38)

Ignition timing:

10° BTDC @ idle

(w/ Terminals TO and E1 connected)

**43. PERFORM ROAD TEST**

Check for abnormal noise, shock, slippage, correct shift points and smooth operation.

**44. RECHECK ENGINE COOLANT LEVEL AND OIL LEVEL**

# CYLINDER BLOCK COMPONENTS FOR ENGINE REMOVAL AND INSTALLATION

ME100-00

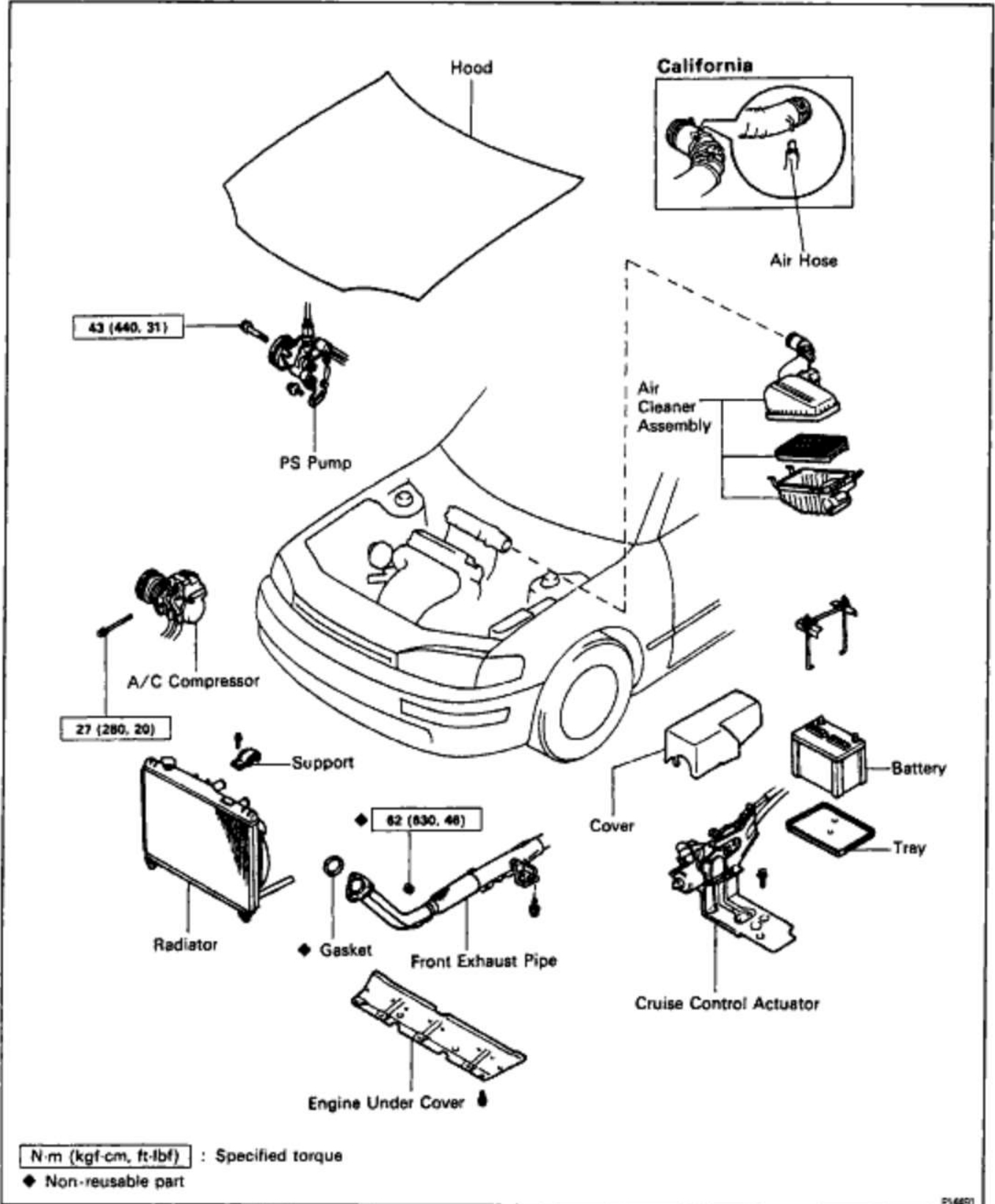

F14651

EG1-84

5S-FE ENGINE - ENGINE MECHANICAL

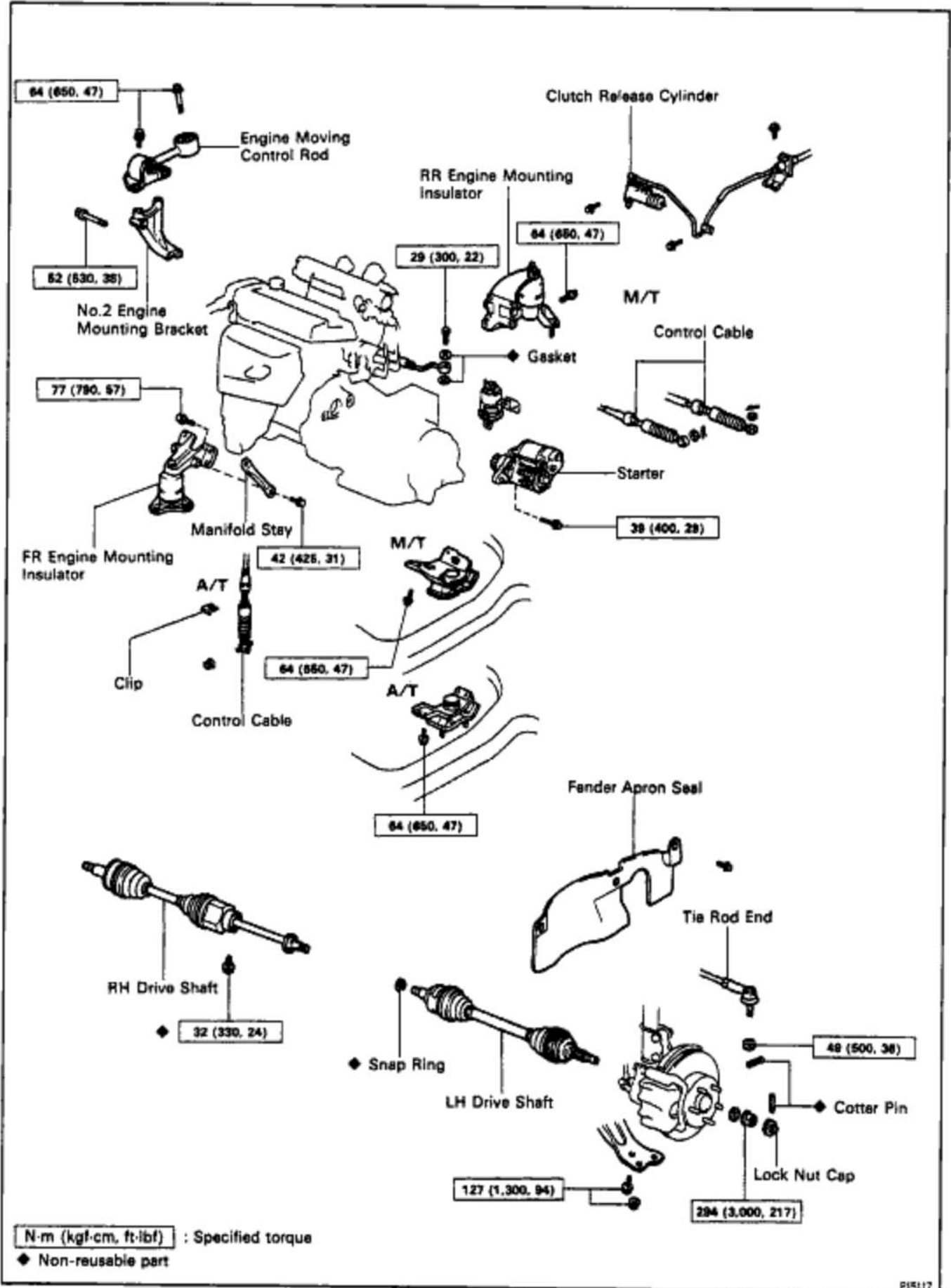

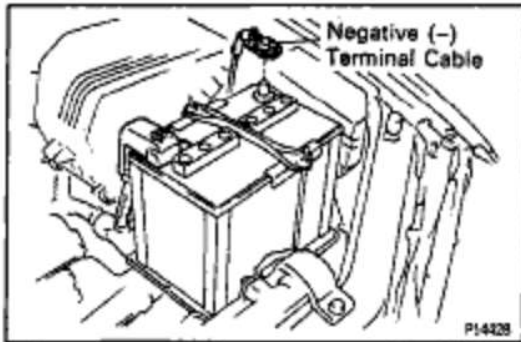

## ENGINE REMOVAL

### 1. DISCONNECT NEGATIVE (-) TERMINAL CABLE FROM BATTERY

**CAUTION:** Work must be started after 90 seconds from the time the ignition switch is turned to the 'LOCK' position and the negative (-) terminal cable is disconnected from the battery.

### 2. REMOVE BATTERY AND TRAY

### 3. REMOVE HOOD

### 4. REMOVE ENGINE UNDER COVER

### 5. DRAIN ENGINE COOLANT

### 6. DRAIN ENGINE OIL

### 7. DISCONNECT ACCELERATOR CABLE FROM THROTTLE BODY

### 8. A/T:

### DISCONNECT THROTTLE CABLE FROM THROTTLE BODY

### 9. REMOVE AIR CLEANER ASSEMBLY, RESONATOR AND AIR CLEANER HOSE

(a) Disconnect the intake air temperature sensor connector.

(b) California only:

Disconnect the air hose from the air cleaner hose.

(c) Loosen the air cleaner hose clamp bolt.

(d) Disconnect the 4 air cleaner cap clips.

(e) Disconnect the air cleaner hose from the throttle body, and remove the air cleaner cap together with the resonator and air cleaner hose.

(f) Remove the element.

(g) Remove the 3 bolts and air cleaner case.

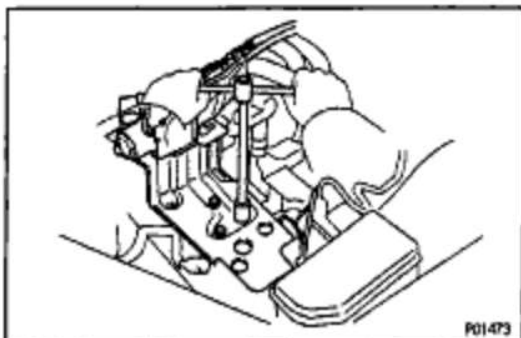
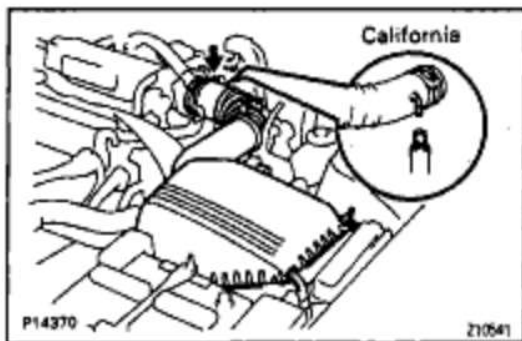

### 10. w/ CRUISE CONTROL SYSTEM: REMOVE CRUISE CONTROL ACTUATOR

(a) Remove the actuator cover.

(b) Disconnect the actuator connector.

(c) Remove the 3 bolts, and disconnect the actuator with the bracket.

### 11. REMOVE RADIATOR

## EG1-86

## 5S-FE ENGINE - ENGINE MECHANICAL

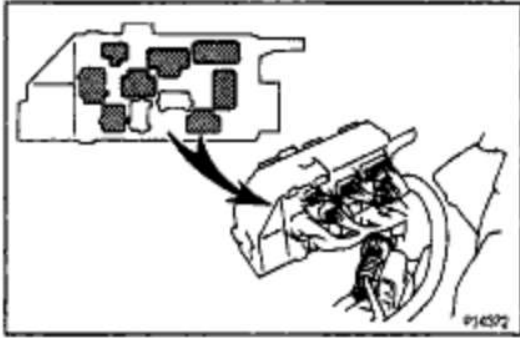
**12. DISCONNECT WIRES AND CONNECTORS**

(a) Remove the engine relay box, and disconnect the 5 connectors.

(b) Connector from LH fender apron

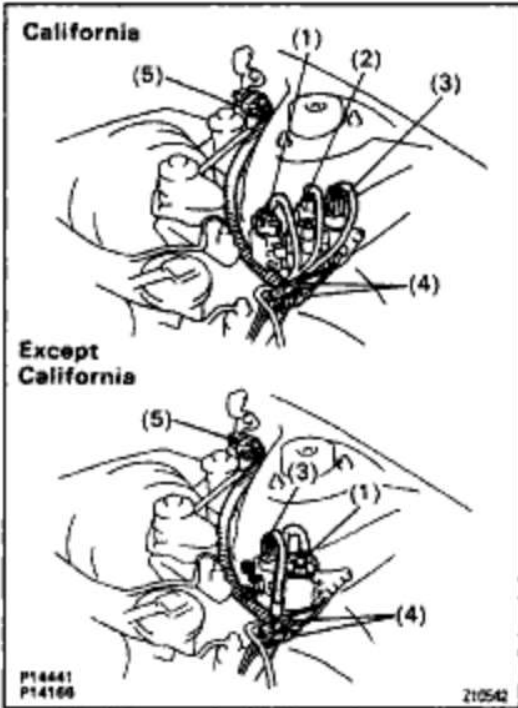

(c) Disconnect the following connectors:

(1) Igniter connector

(2) California only:  
Ignition coil connector

(3) Noise filter connector

(4) 2 ground straps from LH fender apron

(5) Connector from LH fender apron

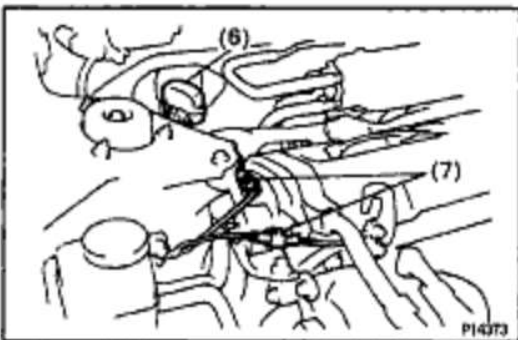

(6) Data link connector 1

(7) 2 ground straps from RH fender apron

(d) Disconnect the MAP sensor connector.

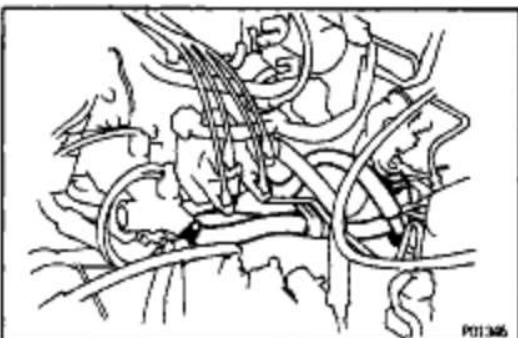
**13. DISCONNECT HEATER HOSES****14. DISCONNECT FUEL RETURN HOSE**

**CAUTION:** Catch leaking fuel in a container.

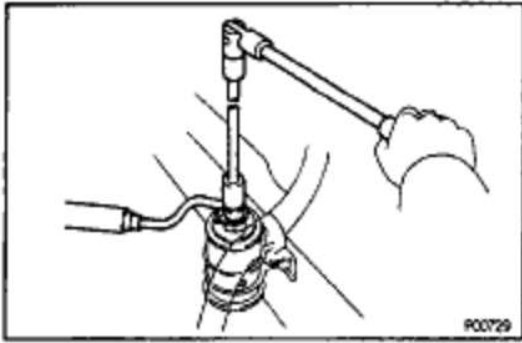
**15. DISCONNECT FUEL INLET HOSE**

**CAUTION:** Catch leaking fuel in a container.

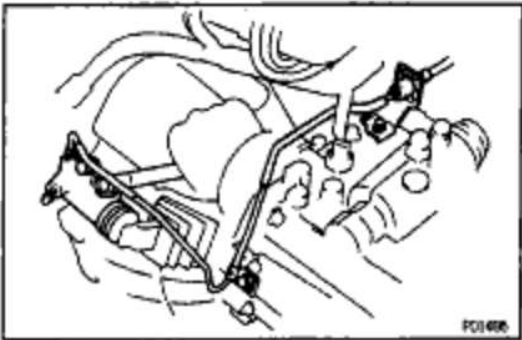
**16. M/T:  
REMOVE STARTER****17. M/T:****REMOVE CLUTCH RELEASE CYLINDER WITHOUT DISCONNECTING TUBE**

Remove the 4 bolts, release cylinder and tube from the transaxle.

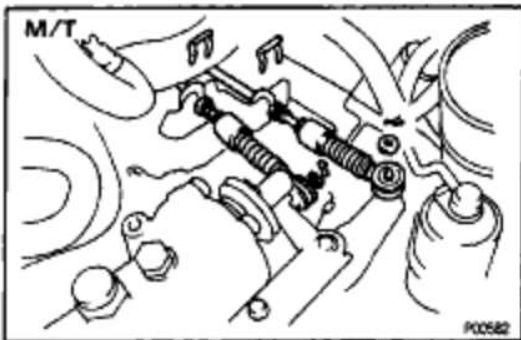
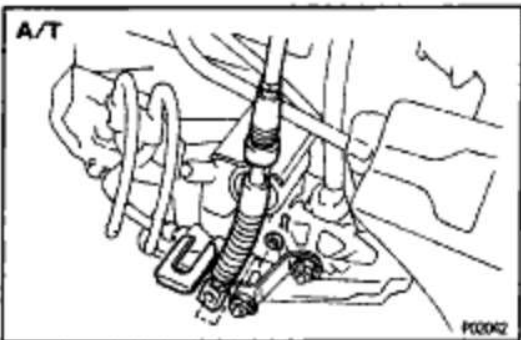
**18. DISCONNECT TRANSAXLE CONTROL CABLE (S) FROM TRANSAXLE****19. DISCONNECT VACUUM HOSES**

(a) MAP sensor hose from air intake chamber

(b) Brake booster vacuum hose from air intake chamber

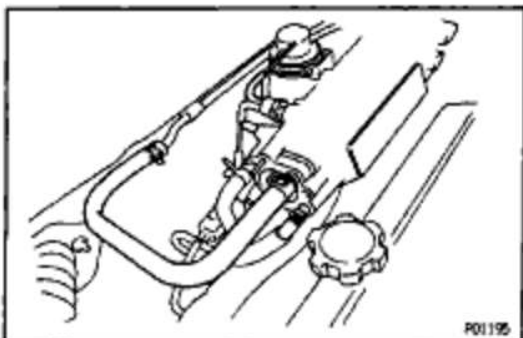

## EG1-88

## 5S-FE ENGINE - ENGINE MECHANICAL

(c) Charcoal canister vacuum hose

## 20. DISCONNECT ENGINE WIRE FROM CABIN

- (a) Remove the under cover.
- (b) Remove the lower instrument panel.
- (c) Remove the glove compartment door.
- (d) Remove the glove compartment.
- (e) Disconnect the following connectors:
  - (1) 2 ECM connectors
  - (2) 2 cowl wire connector

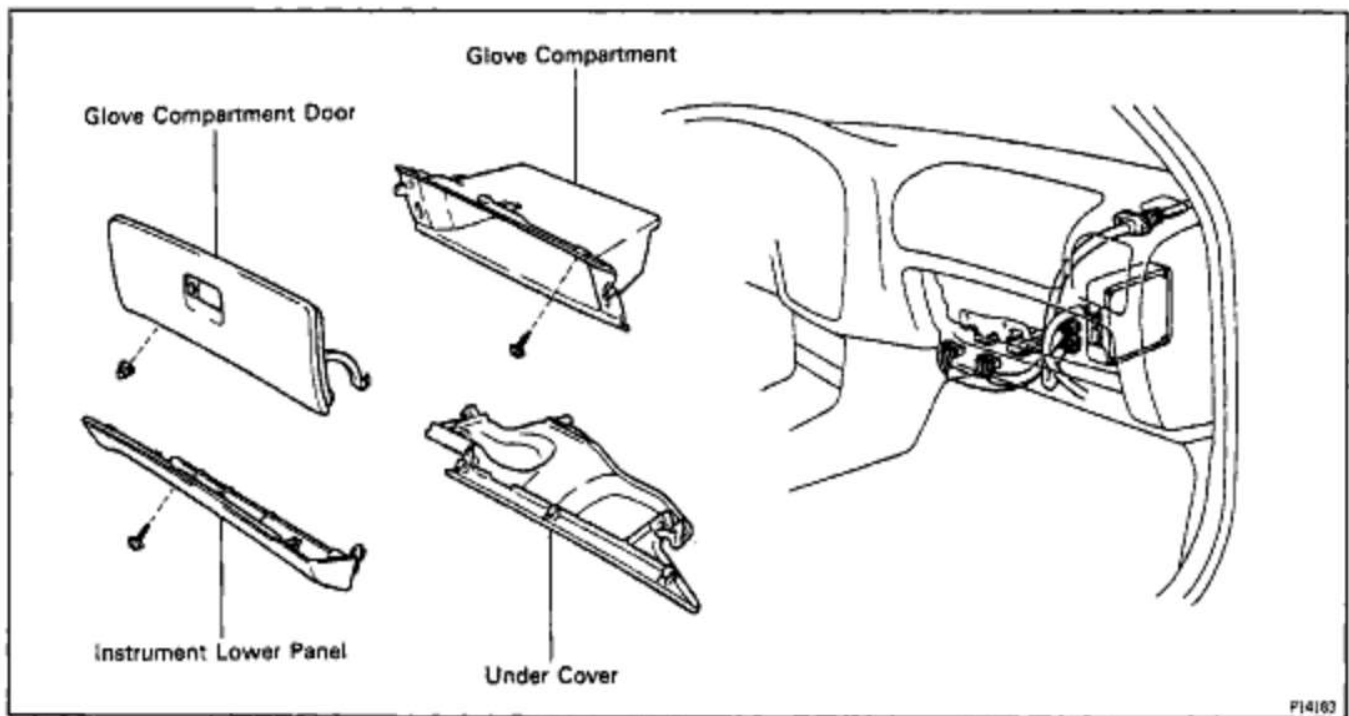

(f) Remove the 2 nuts, and pull out the engine wire from the cowl panel.

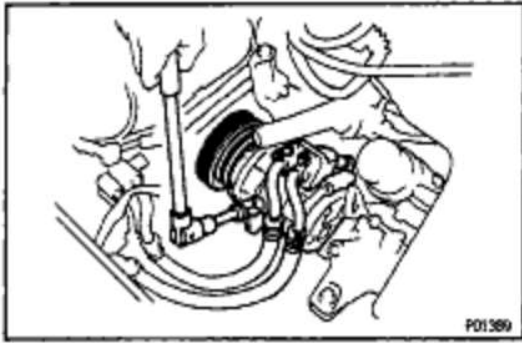

**21. w/ A/C:****REMOVE A/C COMPRESSOR WITHOUT DISCONNECTING HOSES**

- (a) Disconnect the A/C compressor connector.
- (b) Remove the drive belt.
- (c) Remove the 3 bolts, and disconnect the A/C compressor.

HINT: Put aside the compressor, and suspend it to the radiator support with a string.

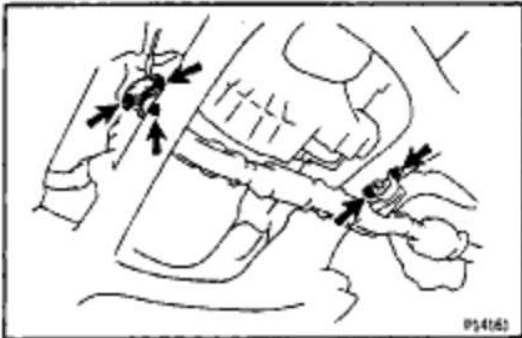
**22. DISCONNECT FRONT EXHAUST PIPE**

- (a) Loosen the 2 bolts, and disconnect the bracket.
- (b) Using a 14 mm deep socket wrench, remove the 3 nuts holding the front exhaust pipe to the WU-TWC.
- (c) Disconnect the front exhaust pipe and gaskets.

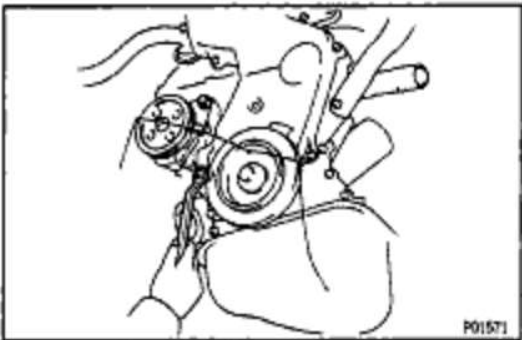
**23. REMOVE DRIVE SHAFTS (See page SA-38)****24. REMOVE PS PUMP WITHOUT DISCONNECTING HOSES**

- (a) Disconnect the 2 air hoses from the air pipe.
- (b) Remove the PS drive belt.
- (c) Remove the 2 bolts, and disconnect the PS pump from the engine.

HINT: Put aside the pump and suspend it from the cowl with a string.

**25. DISCONNECT LH ENGINE MOUNTING INSULATOR****M/T:**

Remove the 3 bolts, and disconnect the mounting insulator.

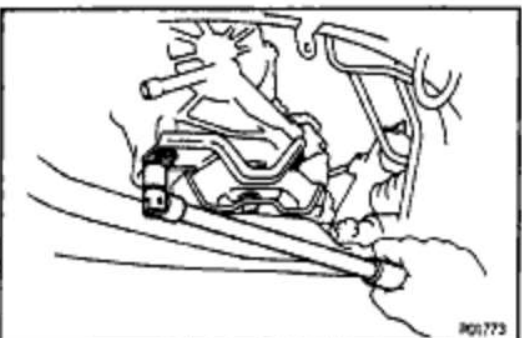
**A/T:**

Remove the 4 bolts, and disconnect the mounting insulator.

## EG1-90

## 5S-FE ENGINE - ENGINE MECHANICAL

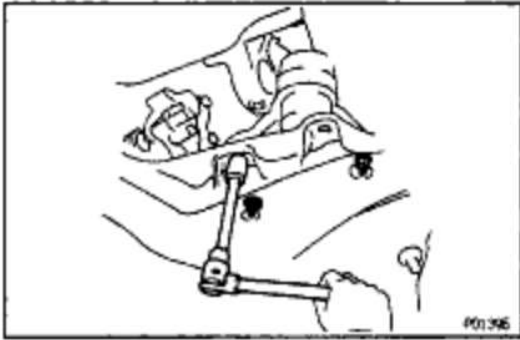
**26. DISCONNECT RR ENGINE MOUNTING INSULATOR**

- (a) Remove the hole plugs.
- (b) Remove the 3 nuts, and disconnect the mounting insulator.

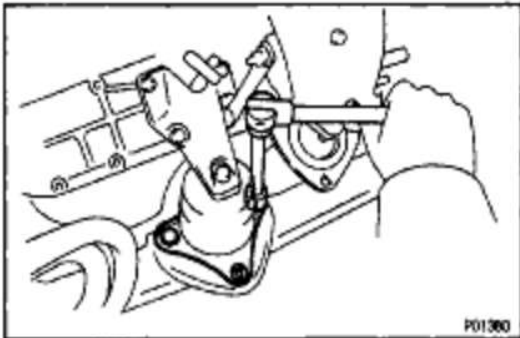
**27. DISCONNECT FR ENGINE MOUNTING INSULATOR**

Remove the 3 bolts, and disconnect the mounting insulator.

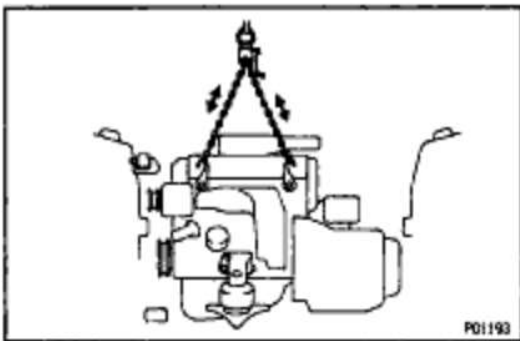
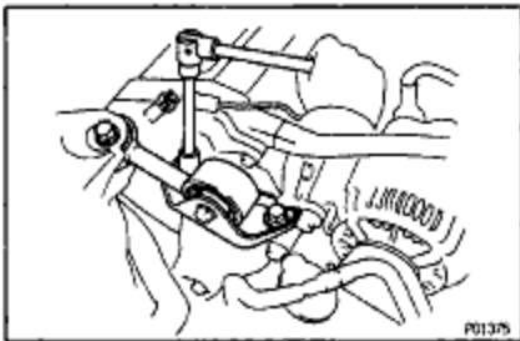
**28. ATTACH ENGINE SLING DEVICE TO ENGINE HANGERS****29. REMOVE ENGINE MOVING CONTROL ROD**

Remove the 3 bolts and control rod.

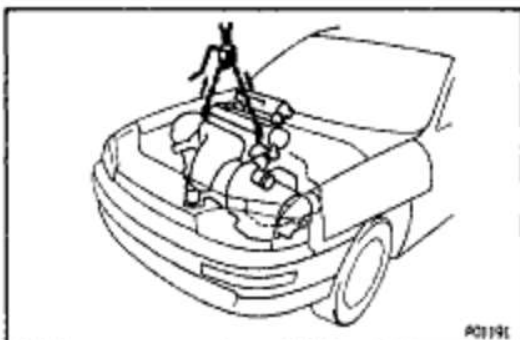
**30. REMOVE ENGINE AND TRANSAXLE ASSEMBLY FROM VEHICLE**

- (a) Lift the engine out of the vehicle slowly and carefully.  
**NOTICE:** Be careful not to hit the PS gear housing or perk/neutral position switch (A/T).
- (b) Make sure the engine is clear of all wiring, hoses and cables.
- (c) Place the engine and transaxle assembly onto the stand.

31. A/T:

**REMOVE STARTER**

32. **SEPARATE ENGINE AND TRANSAXLE**

M/T (See page [MX-10](#))

A/T (See page [AX1-21](#))

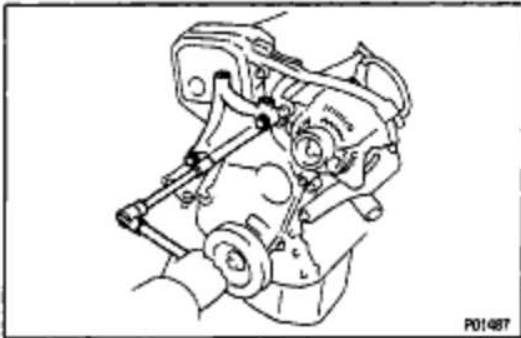

33. **REMOVE NO.2 RH ENGINE MOUNTING BRACKET**

Remove the 3 bolts and engine mounting bracket.

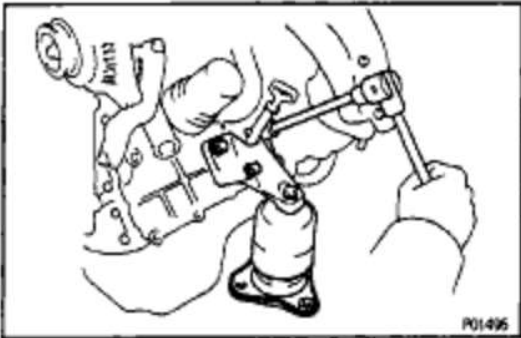

34. **REMOVE FR ENGINE MOUNTING INSULATOR**

(a) Remove the bolt, nut and manifold stay.

(b) Remove the 4 bolts and mounting insulator.

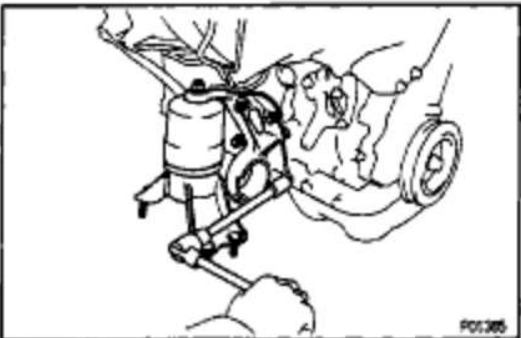

35. **REMOVE RR ENGINE MOUNTING INSULATOR**

Remove the 4 bolts and mounting insulator.

# COMPONENTS FOR CYLINDER BLOCK DISASSEMBLY AND ASSEMBLY

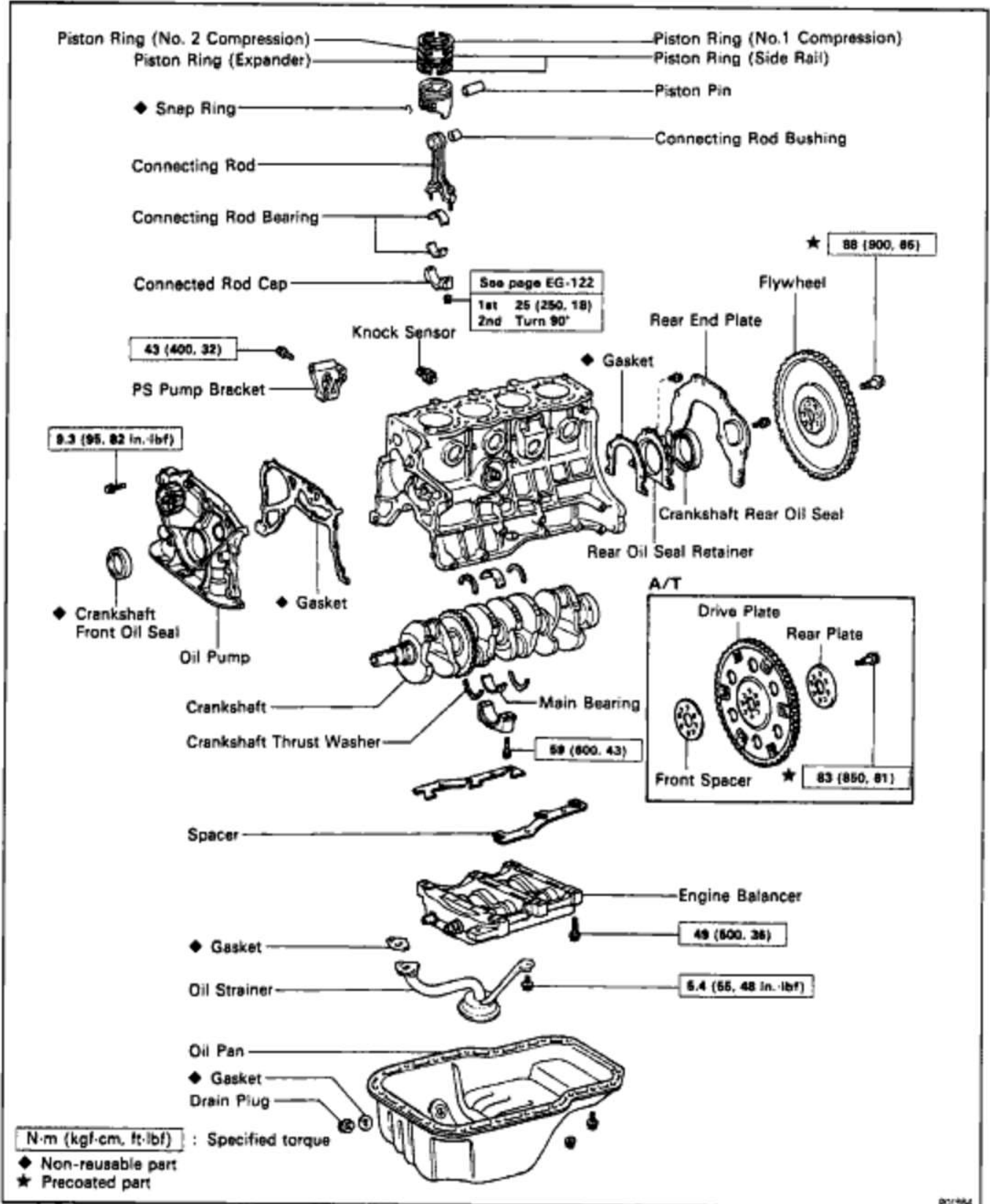

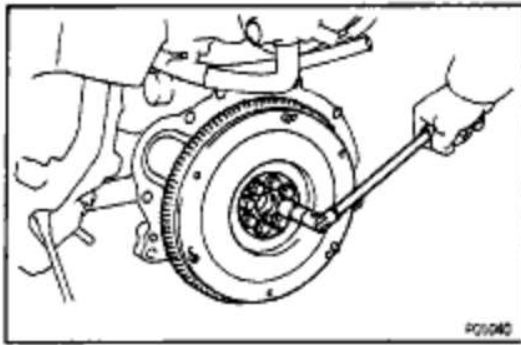

## PREPARATION FOR DISASSEMBLY

1. M/T:  
REMOVE CLUTCH COVER AND DISC
2. M/T:  
REMOVE FLYWHEEL
3. A/T:  
REMOVE DRIVE PLATE

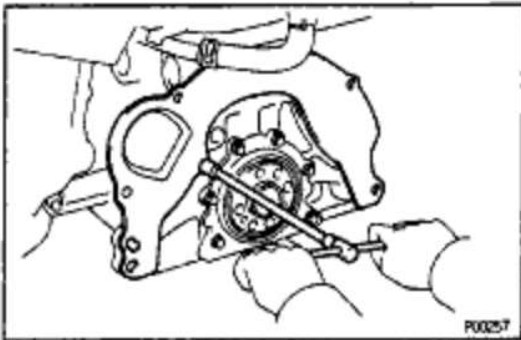

4. REMOVE REAR END PLATE  
Remove the bolt and end plate.
5. INSTALL ENGINE TO ENGINE STAND FOR DISASSEMBLY
6. REMOVE GENERATOR
7. REMOVE DISTRIBUTOR



8. REMOVE PS PUMP BRACKET  
Remove the 3 bolts and PS pump bracket.

9. REMOVE TIMING BELT AND PULLEYS
10. REMOVE CYLINDER HEAD
11. REMOVE WATER PUMP AND GENERATOR  
ADJUSTING BAR
12. REMOVE OIL PAN AND OIL PUMP
13. REMOVE OIL FILTER
14. w/ OIL COOLER:  
REMOVE OIL COOLER

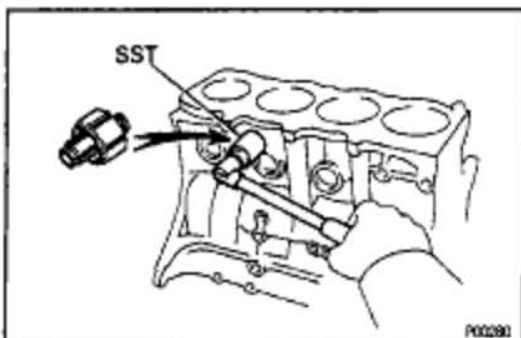

15. REMOVE KNOCK SENSOR  
Using SST, remove the knock sensor.  
SST 09816 - 30010

## EG1-94

## 5S-FE ENGINE - ENGINE MECHANICAL

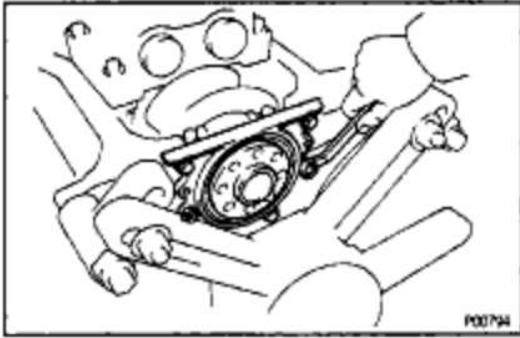
**CYLINDER BLOCK DISASSEMBLY**

(See Components for Cylinder Block Disassembly and Assembly)

**1. REMOVE REAR OIL SEAL RETAINER**

Remove the 6 bolts, retainer and gasket.

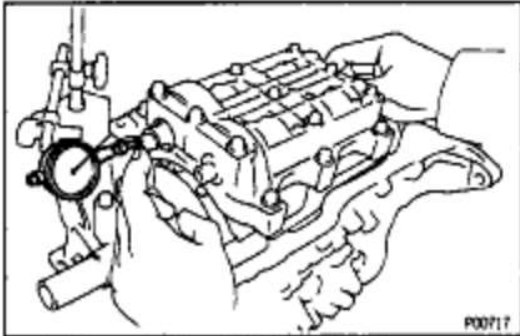
**2. CHECK THRUST CLEARANCES OF NO.1 AND NO.2 BALANCE SHAFT OF ENGINE BALANCER**

Using a dial indicator, measure the thrust clearance while moving the balance shaft back and forth.

**Standard thrust clearance:**

**0.065 – 0.110 mm (0.0026 – 0.0043 in.)**

**Maximum clearance:**

**0.11 mm (0.0043 in.)**

If the clearance is greater than maximum, replace the balance shaft housings and bearings. If necessary, replace the balance shafts.

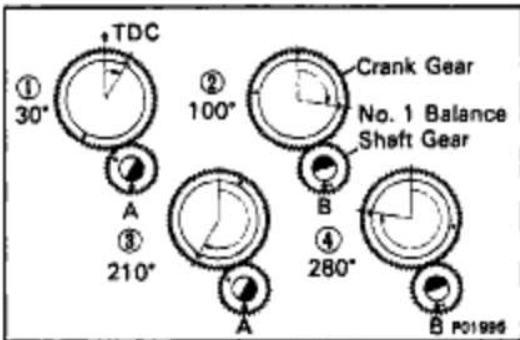
**3. CHECK BACKLASH OF CRANKSHAFT GEAR AND NO.1 BALANCE SHAFT GEAR****NOTICE:**

- Backlash between the crankshaft gear and No.1 balance shaft gear varies with the rotation of the balance shaft and the deviation of the crankshaft gear.
- Accordingly, it is necessary to measure the backlash at the 4 points shown in the illustration on the left. When this inspection is performed on-vehicle, the specifications are increased by approx. 0.025 mm (See specifications below)

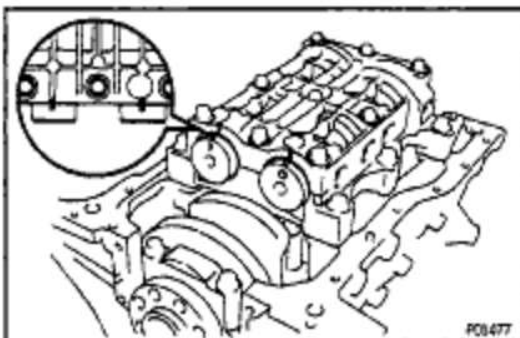

- Rotate the crankshaft 2 or 3 times to settle the crankshaft gear and No.1 balance shaft gear.
- When No.1 piston is at TDC, check that the punch marks shown in the illustration of the balance shafts are aligned with the grooves of the No.2 housing.

## 5S-FE ENGINE - ENGINE MECHANICAL

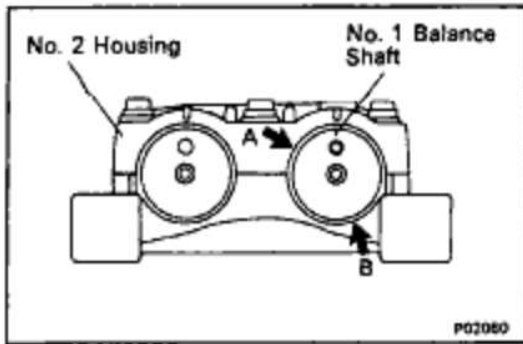

- (c) Check that the punch marks A and B are at the positions on the No.1 balance shaft indicated in the illustration.

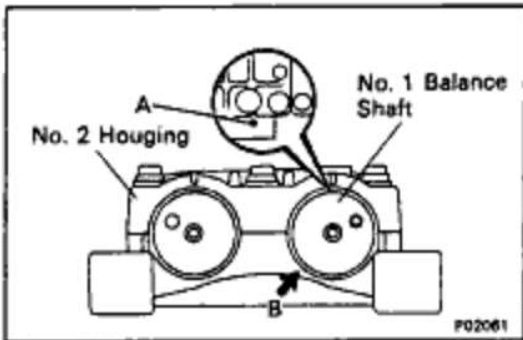

- (d) 1 st turn the crankshaft clockwise, and align the groove of the No.2 balance shaft housing with the punch mark A of the No. 1 balance shaft.

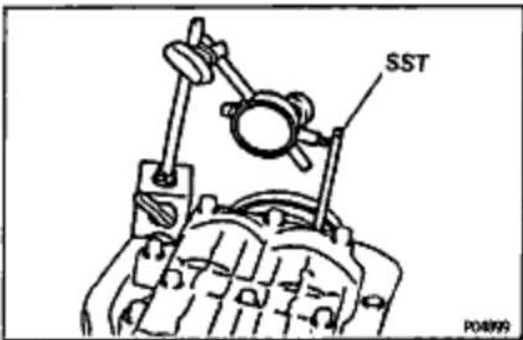

- (e) Set the SST and the dial indicator as shown in the illustration.

SST 09224- 74010

HINT: Make sure that the needle of the dial indicator is perpendicular to the SST and that it is placed in the middle of the third indentation.

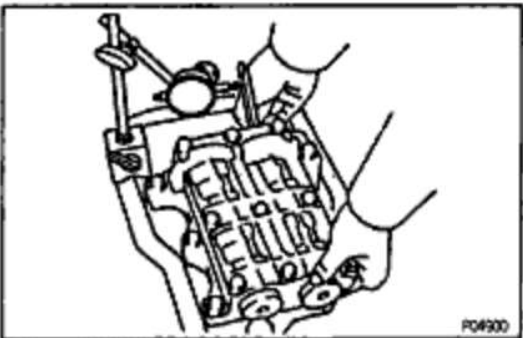

- (f) Lightly turn the No. 1 balance shaft by hand and measure the backlash.

HINT:

- Turn the No.1 balance shaft 4 or 5 times to provide a steady backlash reading.
- To prevent excessive backlash due to thrust clearance, measure the backlash while pressing on the rear of the No.1 balance shaft.

**Standard backlash:**

**Off-vehicle**

0-0.06 mm (0-0.0024 in.)

**On-vehicle**

0.025 - 0.080 mm (0.0010 - 0.0035 in.)

**NOTICE: Do not turn the No.1 balance shaft strongly.**

- (g) Remove the dial gauge and the SST.

## EG1-96

## 5S-FE ENGINE - ENGINE MECHANICAL

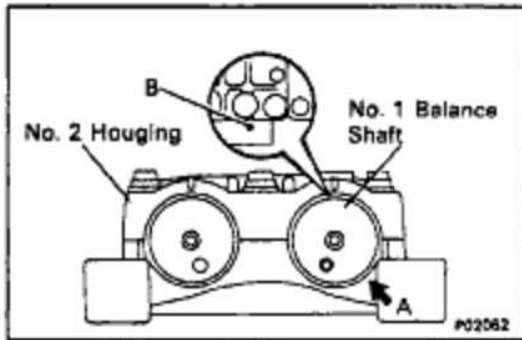

(h) Turn the crankshaft clockwise to align the groove of the No.2 housing with the punch mark B.

(i) Set the dial gauge. (See procedure in step (e))

(j) Measure the backlash. (See procedure in step (f))

**Standard backlash:**

**0 – 0.06 mm (0 – 0.0024 in.)**

(k) Remove the dial gauge.

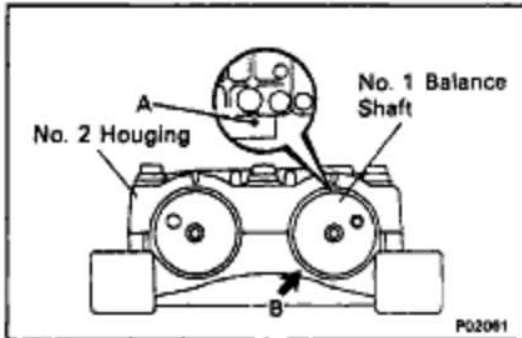

(l) Turn the crankshaft clockwise again to align the groove of the No.2 housing with the punch mark A.

(m) Set the dial gauge. (See procedure in step (e))

(n) Measure the backlash. (See procedure in step (f))

**Standard backlash:**

**0 – 0.06 mm (0 – 0.0024 in.)**

(o) Remove the dial gauge.

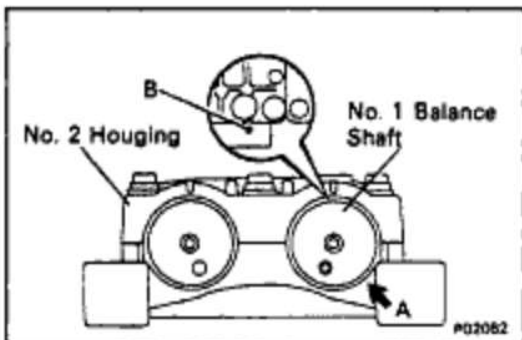

(p) Turn the crankshaft clockwise again to align the groove of the No.2 housing with the punch mark B.

(q) Set the dial gauge. (See procedure in step (e))

(r) Measure the backlash. (See procedure in step (f))

**Standard backlash:**

**0 – 0.06 mm (0 – 0.0024 in.)**

(s) Remove the dial gauge.

If even one of the 4 points measured above exceeds the backlash specification, adjust the backlash with new spacers.

**NOTICE:** Use the same size spacers for both the left and right sides.

**HINT:**

- Varying the spacer thickness by 0.02 mm (0.0008 in.) change the backlash by about 0.014 mm (0.0006 in.).
- If the backlash is greater than permitted maximum, select a thinner shim.
- If the backlash is less than the specification, select a thicker shim.





## EG1-98

## 5S-FE ENGINE - ENGINE MECHANICAL

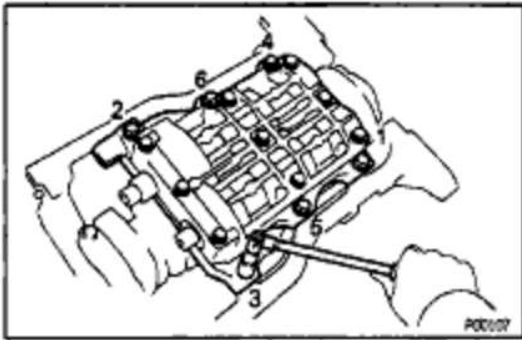
**4. REMOVE ENGINE BALANCER**

- (a) Uniformly loosen and remove the 6 bolts in several passes, in the sequence shown.
- (b) Remove the engine balancer and spacers.

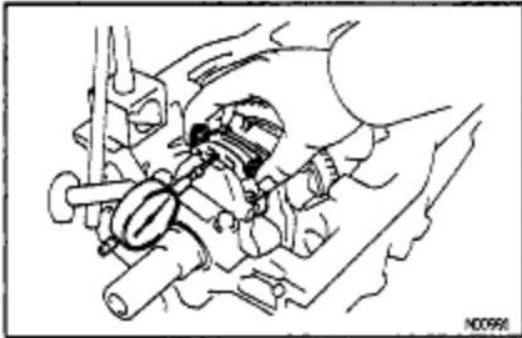
**5. CHECK CONNECTING ROD THRUST CLEARANCE**

Using a dial indicator, measure the thrust clearance while moving the connecting rod back and forth.

**Standard thrust clearance:**

**0.160 – 0.312 mm (0.0063 – 0.0123 in.)**

**Maximum thrust clearance:**

**0.36 mm (0.0138 in.)**

If the thrust clearance is greater than maximum, replace the connecting rod assembly. If necessary, replace the crankshaft.

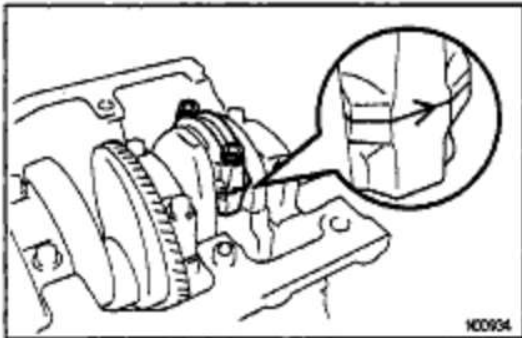
**6. REMOVE CONNECTING ROD CAPS AND CHECK OIL CLEARANCE**

- (a) Check the matchmarks on the connecting rod and cap to ensure correct reassembly.

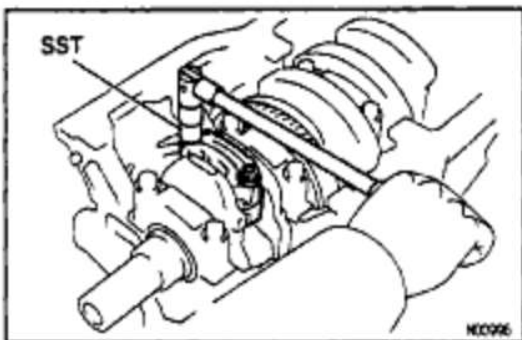

- (b) Using SST, remove the connecting rod cap nuts.  
SST 09011-38121

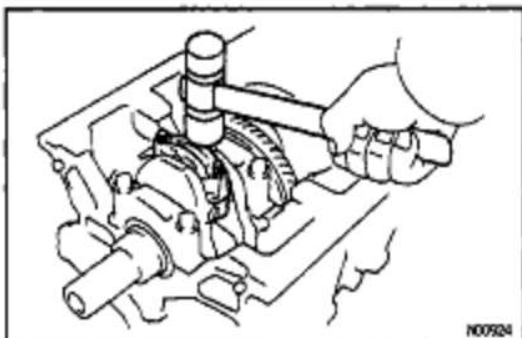

- (c) Using a plastic-faced hammer, lightly tap the connecting rod bolts and lift off the connecting rod cap.  
HINT: Keep the lower bearing inserted with the connecting rod cap.

## 5S-FE ENGINE - ENGINE MECHANICAL

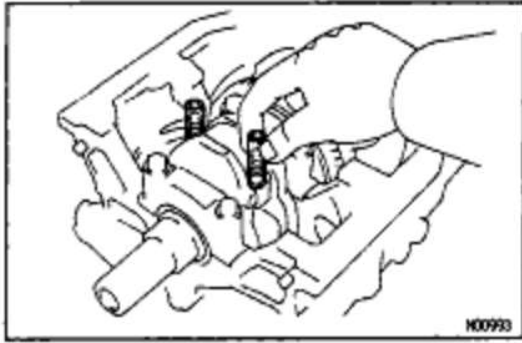

(d) Cover the connecting rod bolts with a short piece of hose to protect the crankshaft from damage.

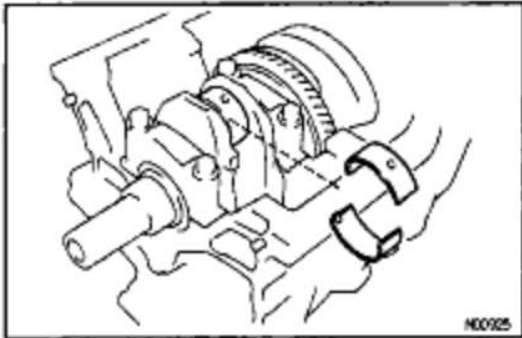

(e) Clean the crank pin and bearing.

(f) Check the crank pin and bearing for pitting and scratches.

If the crank pin or bearing is damaged, replace the bearings. If necessary, grind or replace the crankshaft.



(g) Lay a strip of Plastigage across the crank pin.

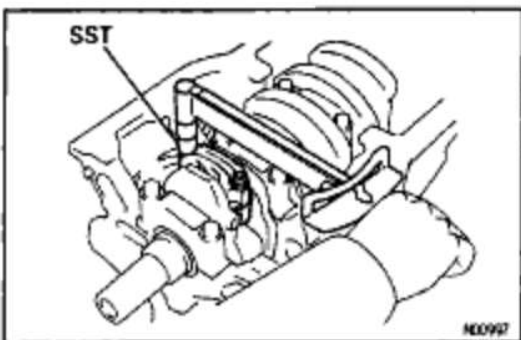

(h) Install the connecting rod cap.

(See step 6 on pages [EG1-122](#))

**1st**

**Torque: 25 N·m (250 kgf·cm, 18 ft·lbf)**

**2nd Turn 90°**

**NOTICE: Do not turn the crankshaft.**

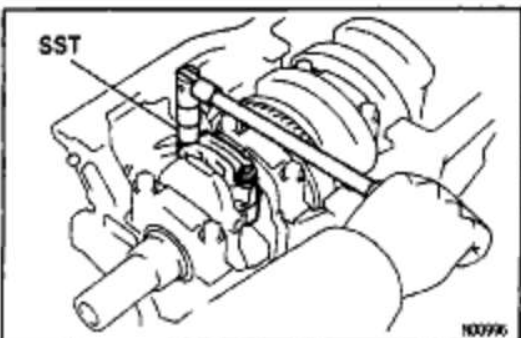

(i) Remove the connecting rod cap.

(See procedure (b) and (c) on the previous page)

## EG1-100

## 5S-FE ENGINE – ENGINE MECHANICAL

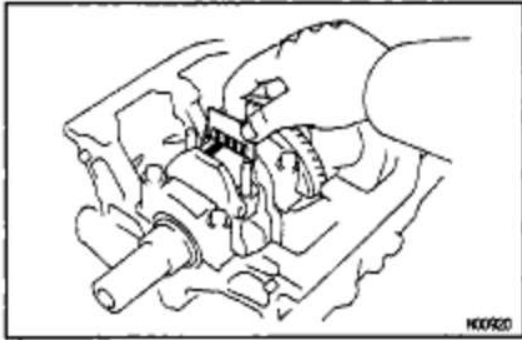

(j) Measure the Plastigage at its widest point.

**Standard oil clearance:**

**STD**

**0.024 – 0.055 mm (0.0009 – 0.0022 in.)**

**U/S 0.25**

**0.023 – 0.069 mm (0.0009 – 0.0027 in.)**

**Maximum oil clearance:**

**0.08 mm (0.0031 in.)**

If the oil clearance is greater than maximum, replace the bearings. If necessary, grind or replace the crankshaft.

HINT: If using a standard bearing, replace it with one having the same number marked on the connecting rod cap. There are 3 sizes of standard bearings, marked \*11, "2" and "3" accordingly.

**Standard sized bearing center wall thickness:**

**Mark "1"**

**1.484 – 1.488 mm (0.0584 – 0.0586 in.)**

**Mark "2"**

**1.488 – 1.492 mm (0.0586 – 0.0587 in.)**

**Mark "3"**

**1.492 – 1.498 mm (0.0587 – 0.0589 in.)**

(k) Completely remove the Plastigage.

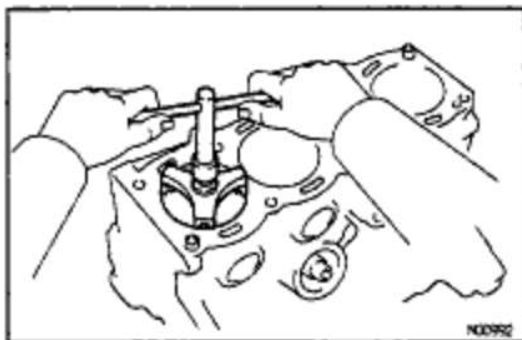
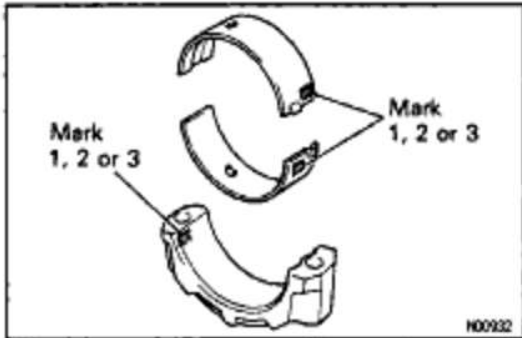

## 7. REMOVE PISTON AND CONNECTING ROD ASSEMBLIES

(a) Using a ridge reamer, remove all the carbon from the top of the cylinder.

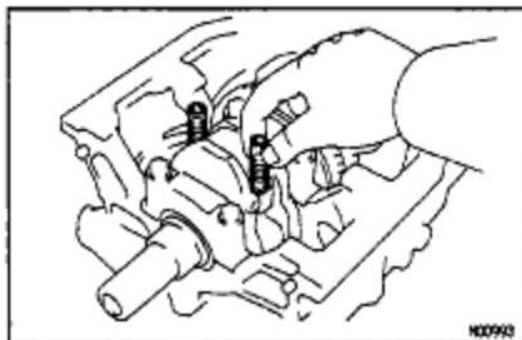

(b) Cover the connecting rod bolts with a short piece of hose to protect the crankshaft from damage.

(c) Push the piston, connecting rod assembly and upper bearing through the top of the cylinder block.

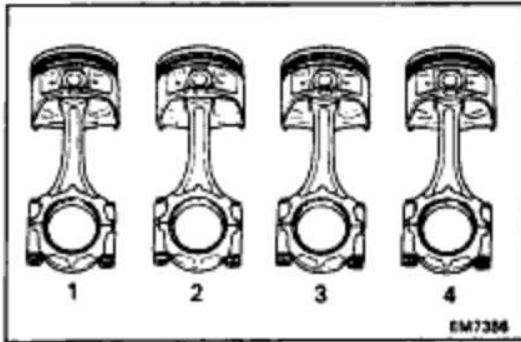
**HINT:**

- Keep the bearings, connecting rod and cap together.
- Arrange the piston and connecting rod assemblies in correct order.

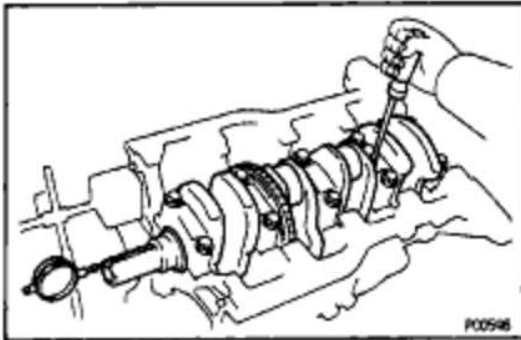
**8. CHECK CRANKSHAFT THRUST CLEARANCE**

Using a dial indicator, measure the thrust clearance while prying the crankshaft back and forth with a screwdriver.

**Standard thrust clearance:**

0.020 – 0.220 mm (0.0008 – 0.0087 in.)

**Maximum thrust clearance:**

0.30 mm (0.0118 in.)

If the thrust clearance is greater than maximum, replace the thrust washers as a set.

**Thrust washer thickness:**

2.440 – 2.490 mm (0.0961 – 0.0980 in.)

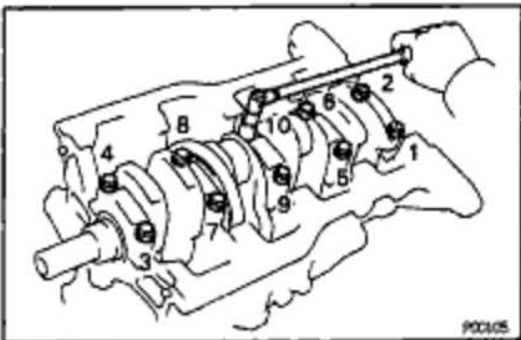
**9. REMOVE MAIN BEARING CAPS AND CHECK OIL CLEARANCE**

- (a) Uniformly loosen and remove the main bearing cap bolts in several passes, in the sequence shown.

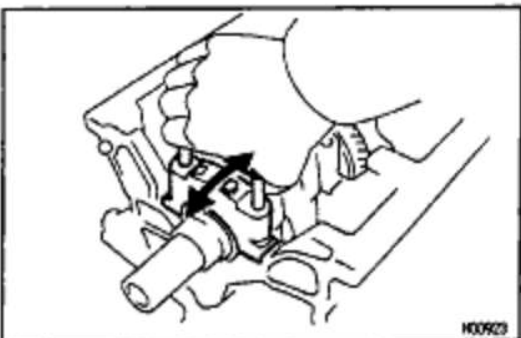

- (b) Using the removed main bearing cap bolts, pry the main bearing cap back and forth, and remove the main bearing caps, lower bearings and lower thrust washers (No.3 main bearing cap only).

**HINT:**

- Keep the lower bearing and main bearing cap together.
- Arrange the main bearing caps and lower thrust washers in correct order.

## EG1-102

## 5S-FE ENGINE - ENGINE MECHANICAL

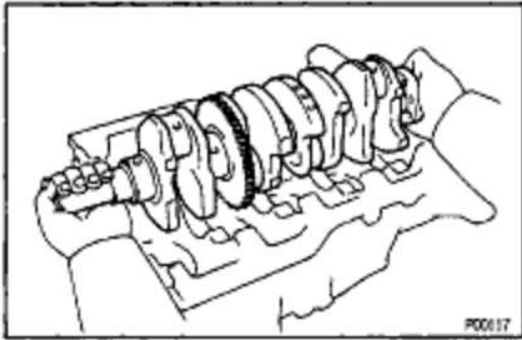

(c) Lift out the crankshaft.

HINT: Keep the upper bearing and upper thrust washers together with the cylinder block.

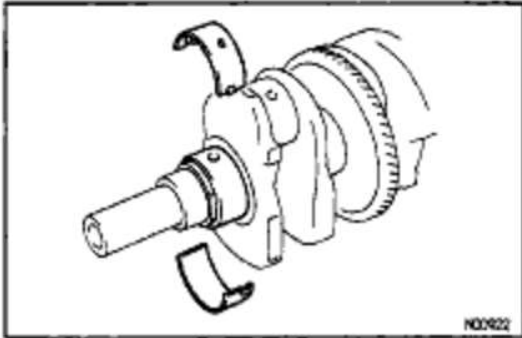

(d) Clean each main journal and bearing.

(e) Check each main journal and bearing for pitting and scratches.

If the journal or bearing is damaged, replace the bearings. If necessary, grind or replace the crankshaft.

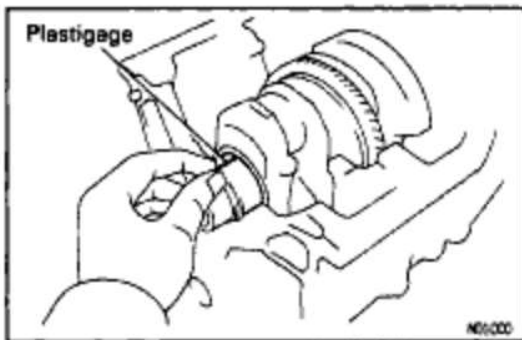

(f) Place the crankshaft on the cylinder block.

(g) Lay a strip of Plastigage across each journal.

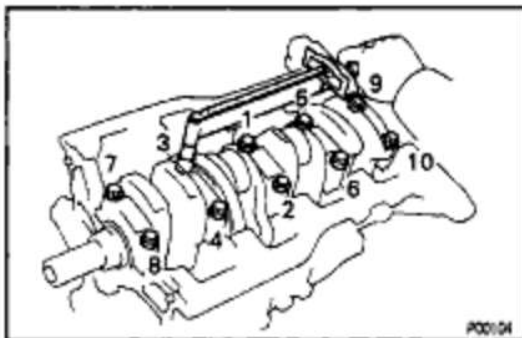

(h) Install the main bearing caps.

(See step 4 on page [EG1-121](#))

**Torque: 59 N-m (600 kgf-cm, 43 ft-lbf)**

**NOTICE: Do not turn the crankshaft.**

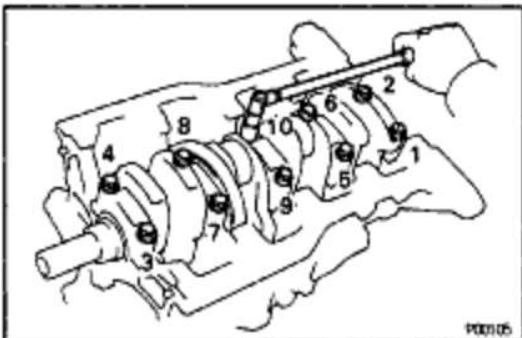

(i) Remove the main bearing caps.

(See procedure (a) and (b) on the previous page)

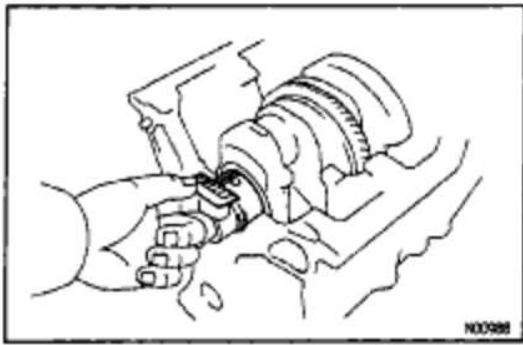

Measure the Plastigage at its widest point.

**Standard clearance:**

**No.3**

**STD**

0.025 – 0.044 mm (0.0010 – 0.0017 in.)

**U/S 0.25**

0.027 – 0.067 mm (0.0011 – 0.0026 in.)

**Others**

**STD**

0.015 – 0.034 mm (0.00015 – 0.0013 in.)

**U/S 0.25**

0.019 – 0.059 mm (0.0007 – 0.0023 in.)

**Maximum clearance:**

0.08 mm (0.0031 in.)

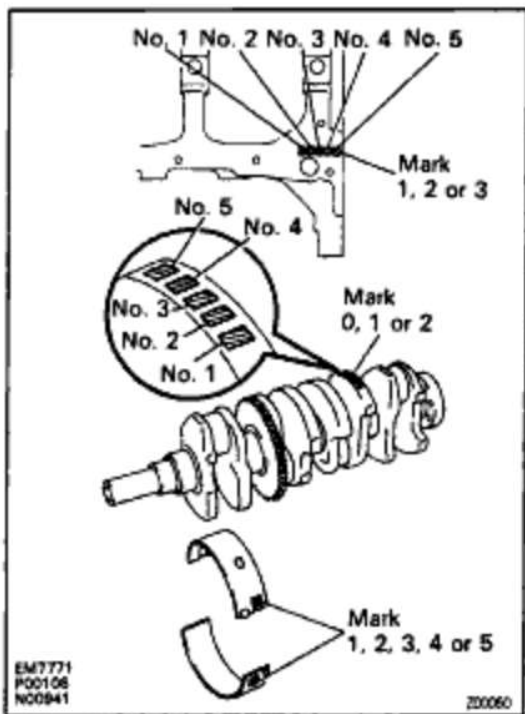

**HINT:** If replacing the cylinder block subassembly, the bearing standard clearance will be:

**No.3:**

0.027 – 0.054 mm (0.0011 – 0.0021 in.)

**Others**

0.017 – 0.044 mm (0.0007 – 0.0017 in.)

If the oil clearance is greater than maximum, replace the bearings. If necessary, grind or replace the crankshaft.

**HINT:** If using a standard bearing, replace it with one having the same number. If the number of the bearing cannot be determined, select the correct bearing by adding together the numbers imprinted on the cylinder block and crankshaft, then selecting the bearing with the same number as the total. There are 5 sizes of standard bearings, marked "1", "2", "3", "4" and "5" accordingly.

	Number marked								
	1			2			3		
Cylinder block									
Crankshaft	0	1	2	0	1	2	0	1	2
Use bearing	1	2	3	2	3	4	3	4	5

**EXAMPLE:** Cylinder block "2" + Crankshaft "11"  
= Total number 3 (Use bearing "3")

W00240

## EG1-104

## 5S-FE ENGINE – ENGINE MECHANICAL

**Reference:****Cylinder block main journal bore diameter:****Mark "1"**

59.020 – 59.026 mm (2.32318 – 2.3239 in.)

**Mark "2"**

59.026 – 59.032 mm (2.3239 – 2.3241 in.)

**Mark "3"**

59.032 – 59.038 mm (2.3241 – 2.3243 in.)

**Crankshaft journal diameter:****Mark "0"**

54.998 – 55.003 mm (2.1653 – 2.1655 in.)

**Mark "11"**

54.993–54.998 mm (2.1651 – 2.1653 in.)

**Mark "2"**

54.988 – 54.993 mm (2.1649 – 2.1651 in.)

**Standard sized bearing center wall thickness:****No-3****Mark "1"**

1.992 – 1.995 mm (0.0784 – 0.0785 in.)

**Mark '2'**

1.995 – 1.998 mm (0.0785 – 0.0787 in.)

**Mark "3"**

1.998 – 2.001 mm (0.0787 – 0.0788 in.)

**Mark '4'**

2.001 – 2.004 mm (0.0788 – 0.0789 in.)

**Mark '5'**

2.004 – 2.007 mm (0.0789 – 0.0790 in.)

**Others****Mark "1"**

1.997 – 2.000 mm (0.0786 – 0.0787 in.)

**Mark '2'**

2.000 – 2.003 mm (0.0787 – 0.0789 in.)

**Mark "3"**

2.003 – 2.006 mm (0.0789 – 0.0790 in.)

**Mark '4'**

2.006 – 2.009 mm (0.0790 – 0.0791 in.)

**Mark '5'**

2.009 – 2.012 mm (0.0791 – 0.0792 in.)

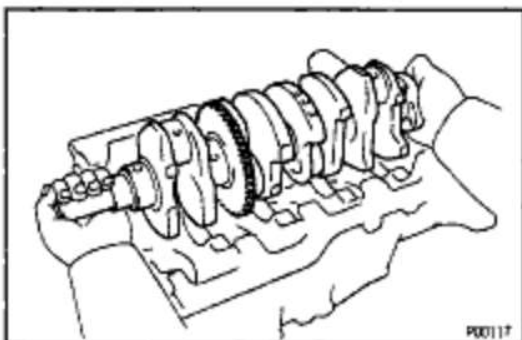

(k) Completely remove the Plastigage.

**10. REMOVE CRANKSHAFT**

(a) Lift out the crankshaft.

(b) Remove the upper bearings and upper thrust washers from the cylinder block.



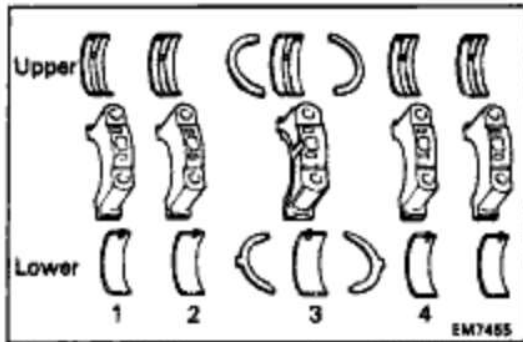

HINT: Arrange the main bearing caps, bearings and thrust washers in correct order.

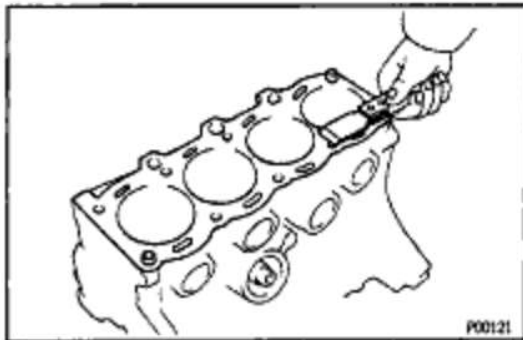

## CYLINDER BLOCK INSPECTION

### 1. CLEAN CYLINDER BLOCK

#### A. Remove gasket material

Using a gasket scraper, remove all the gasket material from the top surface of the cylinder block.

#### B. Clean cylinder block

Using a soft brush and solvent, thoroughly clean the cylinder block.

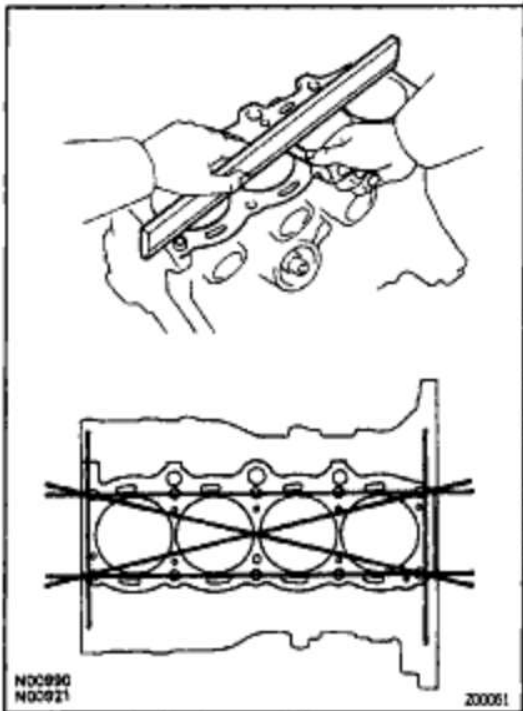

### 2. INSPECT TOP SURFACE OF CYLINDER BLOCK FOR FLATNESS

Using a precision straight edge and thickness gauge, measure the surfaces contacting the cylinder head gasket for warpage.

#### Maximum warpage:

**0.05 mm (0.0020 In.)**

If warpage is greater than maximum, replace the cylinder block.

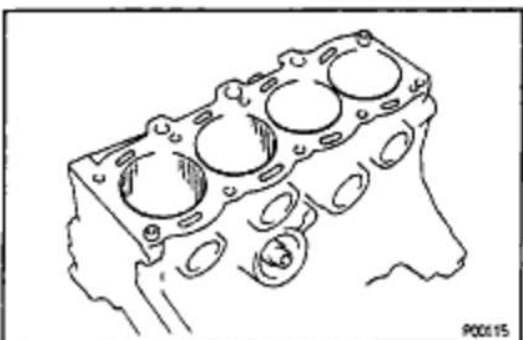

### 3. INSPECT CYLINDER FOR VERTICAL SCRATCHES

Visually check the cylinder for vertical scratches.

If deep scratches are present, rebore all the 4 cylinders. If necessary, replace the cylinder block.

## EG1-106

## 5S-FE ENGINE - ENGINE MECHANICAL

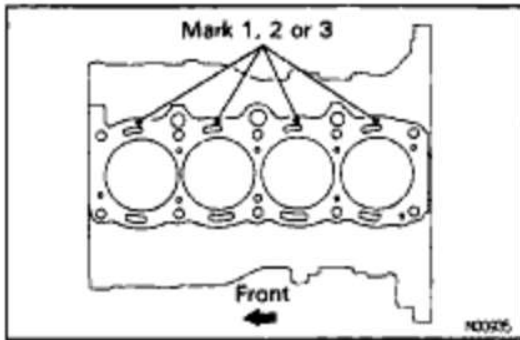
**4. INSPECT CYLINDER BORE DIAMETER**

HINT: There are 3 sizes of the standard cylinder bore diameter, marked "1", "2" and "3" accordingly. The mark is stamped on the top of the cylinder block.

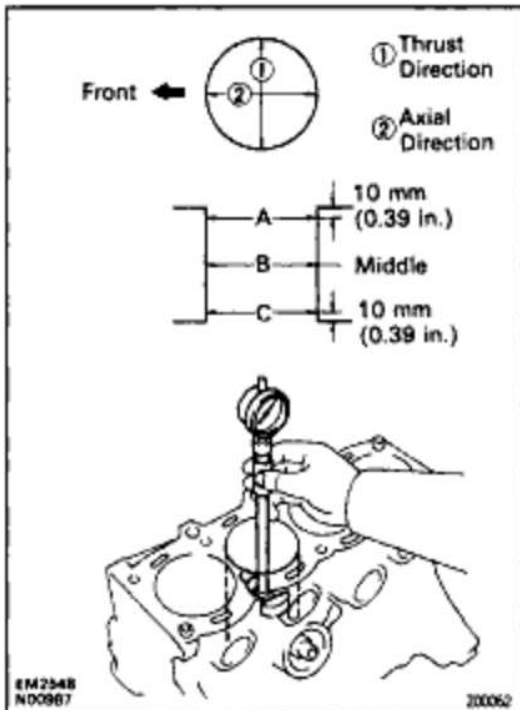

Using a cylinder gauge, measure the cylinder bore diameter at positions A, B and C in the thrust and axial directions.

**Standard diameter:**

**STD**

**Mark "1"**

87.000 – 87.010 mm (3.4252 – 3.4256 in.)

**Mark "2"**

87.010 – 87.020 mm (3.4256 – 3.4260 in.)

**Mark "3"**

87.020 – 87.030 mm (3.4260 – 3.4264 in.)

**Maximum diameter:**

**STD**

87.23 mm (3.4342 in.)

**O/S 0.50**

87.73 mm (3.4350 in.)

If the diameter is greater than maximum, rebore all the 4 cylinders. If necessary, replace the cylinder block.

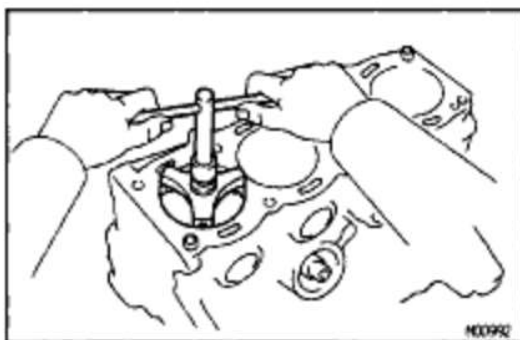
**5. REMOVE CYLINDER RIDGE**

If the wear is less than 0.2 mm (0.008 in.), using a ridge reamer, grind the top of the cylinder.

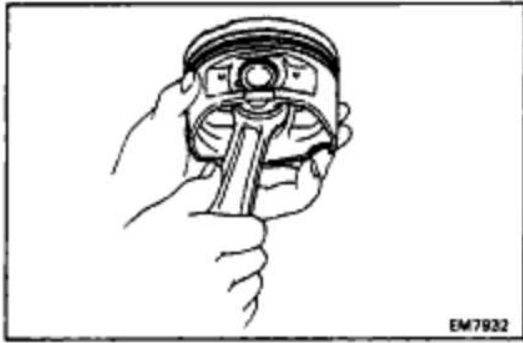

## PISTON AND CONNECTING ROD ASSY DISASSEMBLY

### 1. CHECK FIT BETWEEN PISTON AND PISTON PIN

Try to move the piston back and forth on the piston pin.

If any movement is felt, replace the piston and pin as a set.

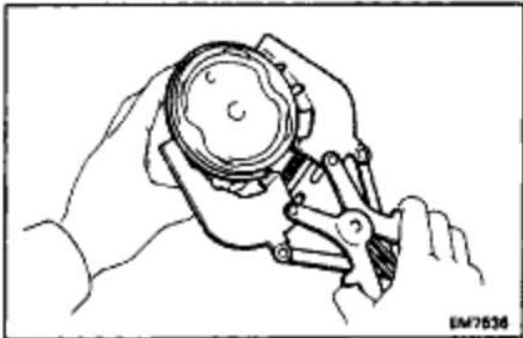

### 2. REMOVE PISTON RINGS

- (a) Using a piston ring expander, remove the 2 compression rings.



- (b) Remove the 2 side rails and oil ring by hand.  
HINT: Arrange the rings in correct order only.

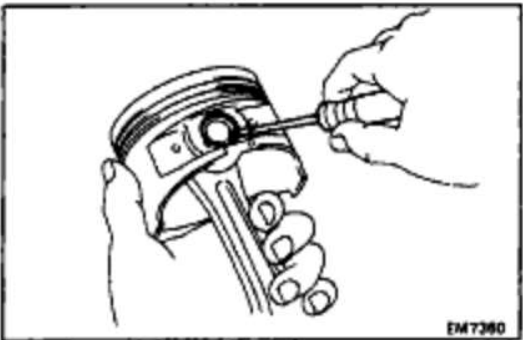

### 3. DISCONNECT CONNECTING ROD FROM PISTON

- (a) Using a small screwdriver, pry out the 2 snap rings.

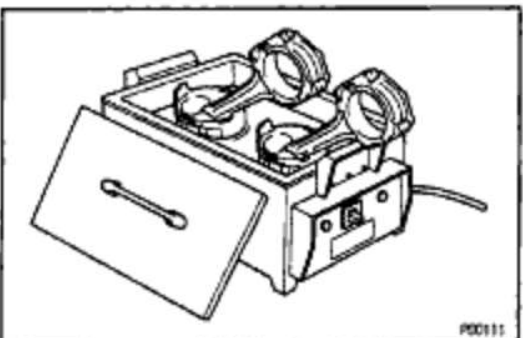

- (b) Gradually heat the piston to 80–90°C (176–194°F).

## EG1-108

## 5S-FE ENGINE - ENGINE MECHANICAL

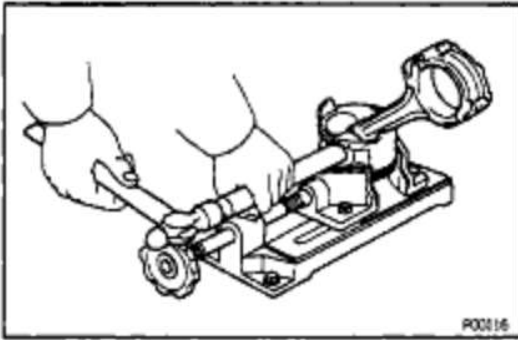

- (c) Using plastic-faced hammer and brass bar, lightly tap out the piston pin and remove the connecting rod.

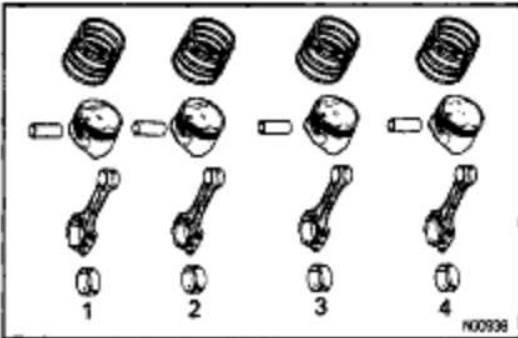

## HINT:

The piston and pin are a matched set.

Arrange the pistons, pins, rings, connecting rods and bearings in correct order.

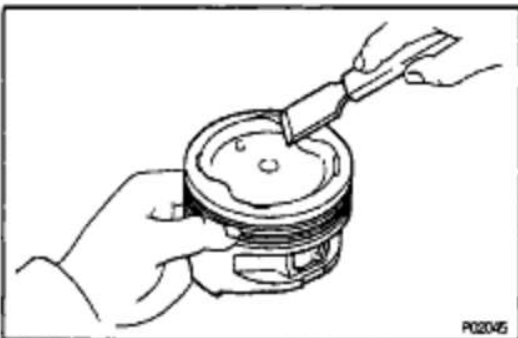

## PISTON AND CONNECTING ROD INSPECTION

### 1. CLEAN PISTON

- (a) Using a gasket scraper, remove the carbon from the piston top.

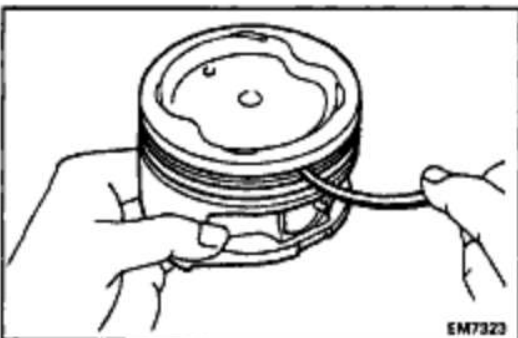

- (b) Using a groove cleaning tool or broken ring, clean the piston ring grooves.

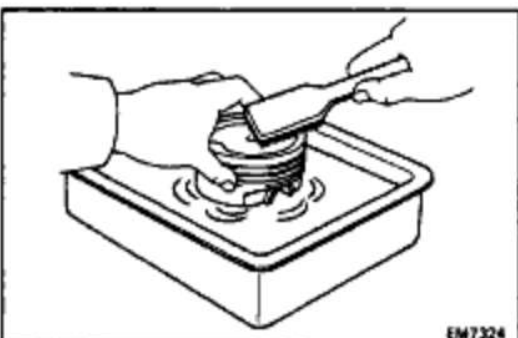

- (c) Using solvent and a brush, thoroughly clean the piston.

**NOTICE:** Do not use a wire brush.

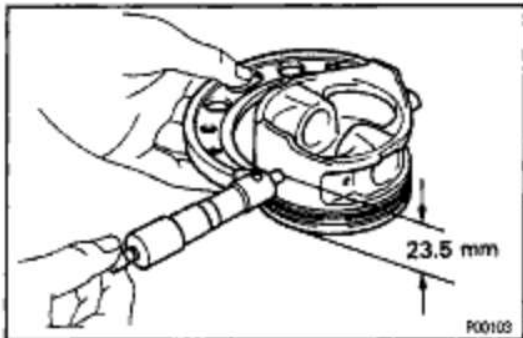
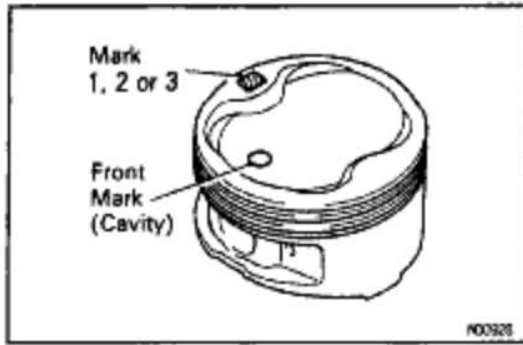

## 2. INSPECT PISTON

### A. Inspect piston oil clearance

HINT: There are 3 sizes of the standard piston diameter, marked "1", "2" and "3" accordingly. The mark is stamped on the piston top.

- (a) Using a micrometer, measure the piston diameter at ring angles to the piston pin center line, 23.5 mm (0.925 in.) from the piston head.

#### Piston diameter:

##### STD

##### Mark "1"

86.85–86.86 mm (3.4193 – 3.4197 in.)

##### Mark "2"

86.86–86.87 mm (3.4197 – 3.4201 in.)

##### Mark "3"

86.87 – 86.88 mm (3.4201 – 3.4205 in.)

##### O/S 0.50

87.35 – 87.38 mm (3.4390 – 3.4402 in.)

- (b) Measure the cylinder bore diameter in the thrust directions.

(See step 4 on page [EG1-106](#))

- (c) Subtract the piston diameter measurement from the cylinder bore diameter measurement.

#### Standard oil clearance:

0.14 – 0.16 mm (0.0055 – 0.0063 in.)

#### Maximum oil clearance:

0.18 mm (0.0071 in.)

If the oil clearance is greater than maximum, replace all the 4 pistons and rebore all the 4 cylinders. If necessary, replace the cylinder block.

HINT (Use new cylinder block): Use a piston with the same number mark as the cylinder bore diameter marked on the cylinder block.

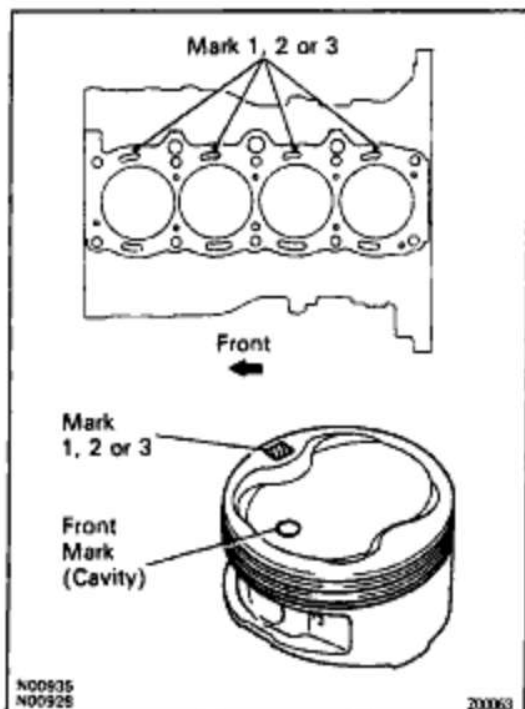

## EG1-110

## 5S-FE ENGINE - ENGINE MECHANICAL

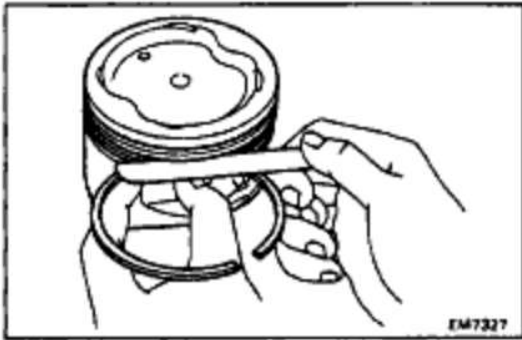
**B. Inspect piston ring groove clearance**

Using a thickness gauge, measure the clearance between new piston ring and the wall of the piston ring groove.

**Ring groove clearance:****No.1**

0.040 – 0.080 mm (0.0016 – 0.0031 in.)

**No.2**

0.030 – 0.070 mm (0.0012 – 0.0028 in.)

If the clearance is greater than maximum, replace the piston.

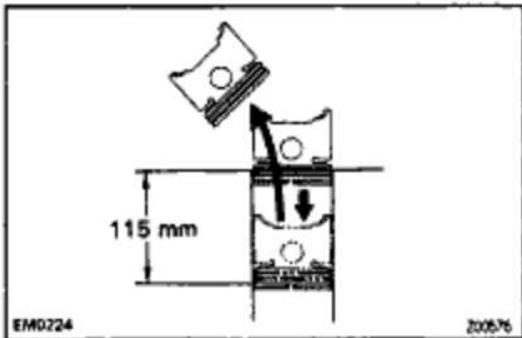
**C. Inspect piston ring end gap**

- (a) Insert the piston ring into the cylinder bore.
- (b) Using a piston, push the piston ring a little beyond the bottom of the ring travel, 115 mm (4.53 in.) from the top of the cylinder block.

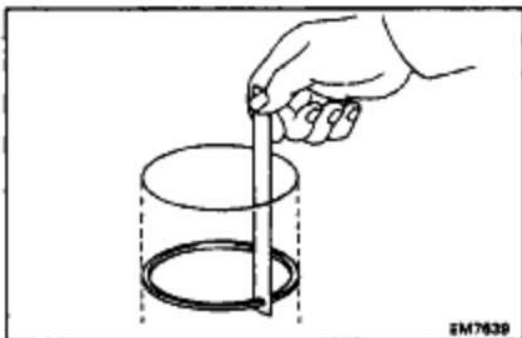

- (c) Using a thickness gauge, measure the end gap.

**Standard and gap:****No.1**

0.270 – 0.500 mm (0.0106 – 0.0197 in.)

**No.2**

0.350 – 0.600 mm (0.0138 – 0.0234 in.)

**Oil (Side rail)**

0.200 – 0.550 mm (0.0079 – 0.0217 in.)

**Maximum end gap:****No.1**

1.10 mm (0.0433 in.)

**No.2**

1.20 mm (0.0472 in.)

**Oil (Side rail)**

1.15 mm (0.0453 in.)

If the end gap is greater than maximum, replace the piston ring. If the end gap is greater than maximum, even with a new piston ring, rebore all the 4 cylinders or replace the cylinder block.

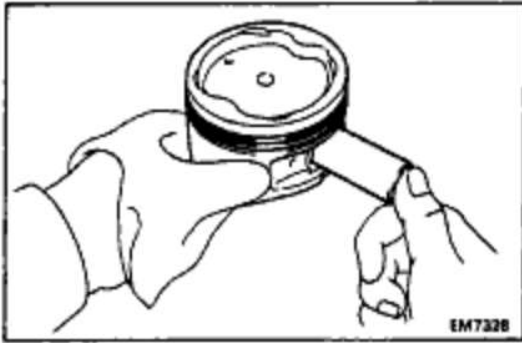

#### D. Inspect-piston pin fit

At 60°C (140°F), you should be able to push the piston pin into the piston pin hole with your thumb.

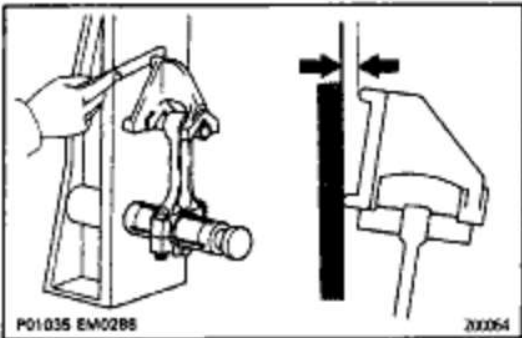

### 3. INSPECT CONNECTING ROD

#### A. Inspect connecting rod alignment

Using a rod aligner and thickness gauge, check the connecting rod alignment.

- Check for bend.

**Maximum bend:**

**0.05 mm (0.0020 in.) per 100 mm (3.94 in.)**

If bend is greater than maximum, replace the connecting rod assembly.

- Check for twist

**Maximum twist:**

**0.15 mm (0.0059 in.) per 100 mm (3.94 in.)**

If twist is greater than maximum, replace the connecting rod assembly.

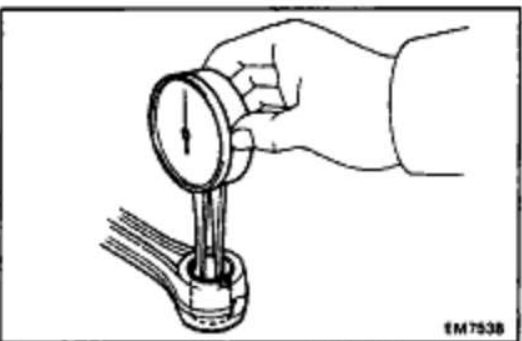
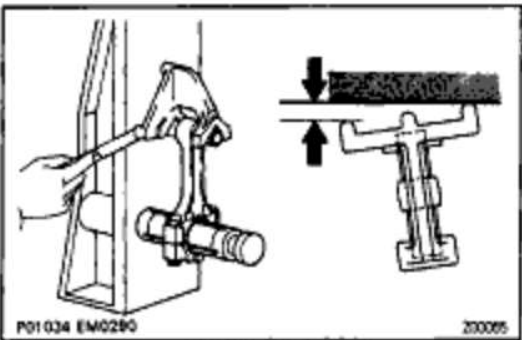

#### B. Inspect piston pin oil clearance

- (a) Using a caliper gauge, measure the inside diameter of the connecting rod bushing.

**Bushing inside diameter:**

**22.005 – 22.017 mm (0.8663 – 0.8668 in.)**

- (b) Using a micrometer, measure the piston pin diameter.

**Piston pin diameter:**

**21.997 – 22.009 mm (0.8660 – 0.8665 in.)**

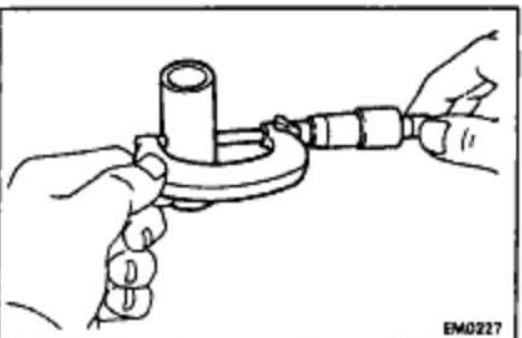

## EG1-112

## 5S-FE ENGINE - ENGINE MECHANICAL

- (c) Subtract the piston pin diameter measurement from the bushing inside diameter measurement.  
 Standard oil clearance:  
 0.005 – 0.011 mm (0.0002 – 0.0004 in.)  
 Maximum oil clearance:  
 0.05 mm (0.0020 In.)  
 If the oil clearance is greater than maximum, replace the bushing. If necessary, replace the piston and piston pin as a set.

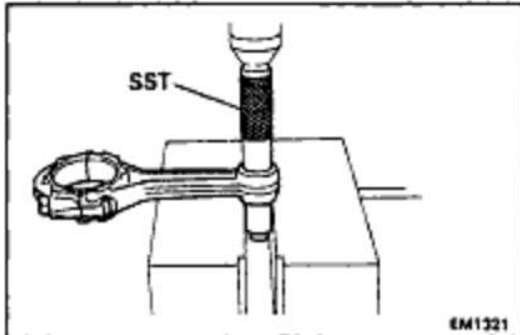

**C. If necessary, replace connecting rod bushing**

- (a) Using SST and a press, press out the bushing.  
 SST 09222 – 30010

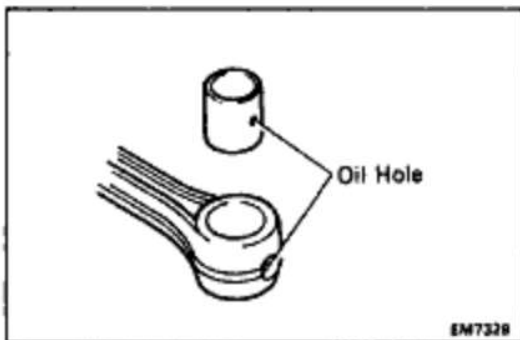

- (b) Align the oil holes of a new bushing and the connecting rod.

- (c) Using SST and a press, press in the bushing.  
 SST 09222-30010

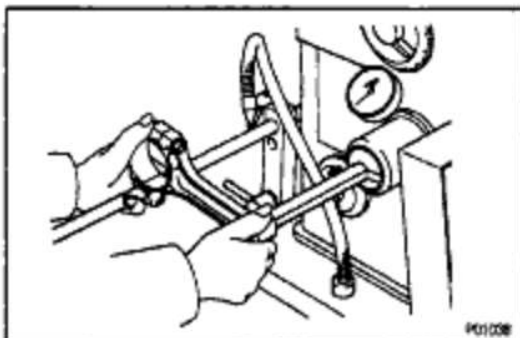

- (d) Using a pin hole grinder, hone the bushing to obtain the standard specified clearance (see step B above) between the bushing and piston pin.

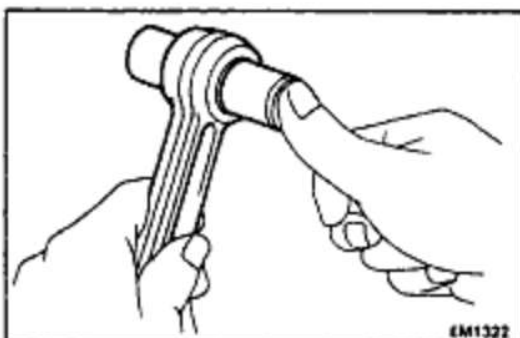

- (e) Check the piston pin fit at normal room temperature.  
 Coat the piston pin with engine oil, and push it into the connecting rod with your thumb.



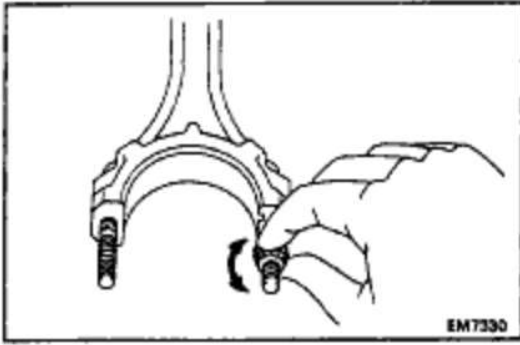

#### D. Inspect connecting rod bolts

- (a) Install the cap nut to the connecting rod bolt. Check that the cap nut can be turned easily by hand to the end of the thread.

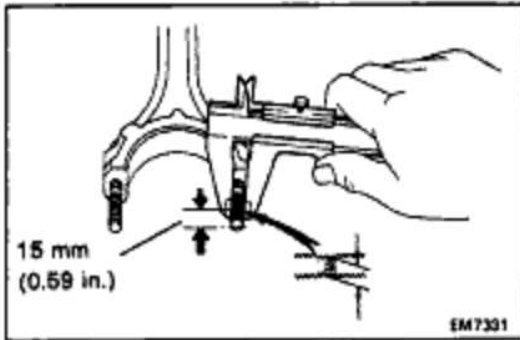

- (b) If the cap nut cannot be turned easily, measure the outside diameter of the connecting rod bolt with a vernier caliper.

**Standard outside diameter:**

**7.860–8.000 mm (0.3094–0.3150 in.)**

**Minimum outside diameter:**

**7.60 mm (0.2992 in.)**

**HINT:** If the location of this area cannot be judged by visual inspection, measure the outer diameter at the location shown in the illustration.

If the outside diameter is less than minimum, replace the connecting rod bolt and nut as a set.

## CYLINDER BORING

### HINT:

- Bore all the 4 cylinders for the oversized piston outside diameter.
- Replace all the piston rings with ones to match the oversized pistons.

### 1. KEEP OVERSIZED PISTONS

Oversized piston diameter:

O/S 0.50

87.35 – 87.38 mm (3.4390–3.4402 in.)

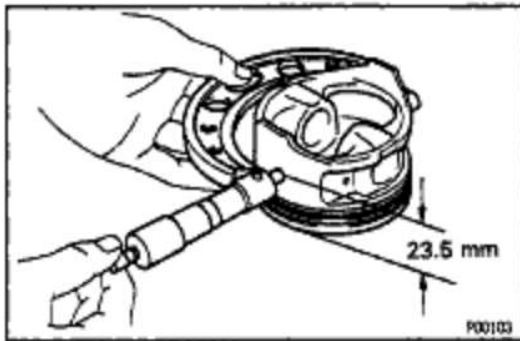

### 2. CALCULATE AMOUNT TO BORE CYLINDERS

- Using a micrometer, measure the piston diameter at right angles to the piston pin center line, 23.5 mm (0.925 in.) from the piston head.
- Calculate the amount of each cylinder is to be rebored as follows:

**Size to be rebored = P + C – H**

**P = Piston diameter**

**C = Piston clearance**

0.14 – 0.18 mm (0.0055 – 0.0063 in.)

**H = Allowance for honing**

0.20 mm (0.0008 in.) or less

### 3. BORE AND HONE CYLINDER TO CALCULATED DIMENSIONS

Maximum honing:

0.02 mm (0.0008 in.)

**NOTICE:** Excess honing will destroy the finished roundness.

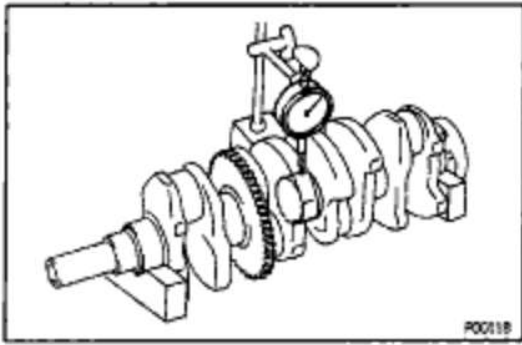

## CRANKSHAFT INSPECTION AND REPAIR

### 1. INSPECT CRANKSHAFT FOR RUNOUT

- (a) Place the crankshaft on V-blocks.
- (b) Using a dial indicator, measure the circle runout at the center journal.

**Maximum circle runout:**

**0.06 mm (0.0024 in.)**

If the circle runout is greater than maximum, replace the crankshaft.

### 2. INSPECT MAIN JOURNALS AND CRANK PINS

- (a) Using a micrometer, measure the diameter of each main journal and crank pin.

**Main journal diameter:**

**STD size**

**54.988 – 55.003 mm (2.1653–2.1655 in.)**

**U/S 0.25**

**54.745 – 54.755 mm (2.1553–2.1557 in.)**

**Crank pin diameter:**

**STD size**

**51.985 – 52.000 mm (2.0466–2.0472 in.)**

**U/S 0.25**

**51.745 – 51.755 mm (2.0372–2.0376 in.)**

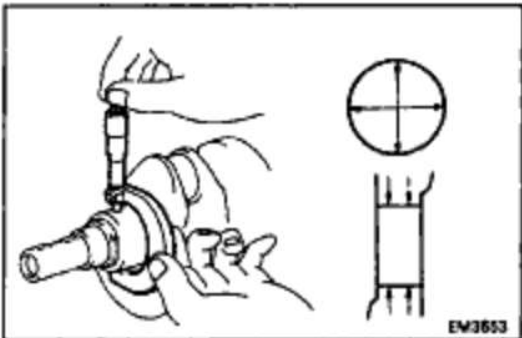

If the diameter is not as specified, check the oil clearance (See pages [EG1-98](#) to 104). If necessary, grind or replace the crankshaft.

- (b) Check each main journal and crank pin for taper and out-of-round as shown.

**Maximum taper and out-of-round:**

**0.02 mm (0.0008 in.)**

If the taper and out-of-round is greater than maximum, replace the crankshaft.

### 3. IF NECESSARY. GRIND AND HONE MAIN JOURNALS AND/OR CRANK PINS

Grind and hone the main journals and/or crank pins to the finished undersized diameter (See procedure in step 2).

Install new main journal and/or crankshaft pin undersized bearings.

## CRANKSHAFT OIL SEALS REPLACEMENT

HINT: There are 2 methods (A and B) to replace the oil seal which are as follows:

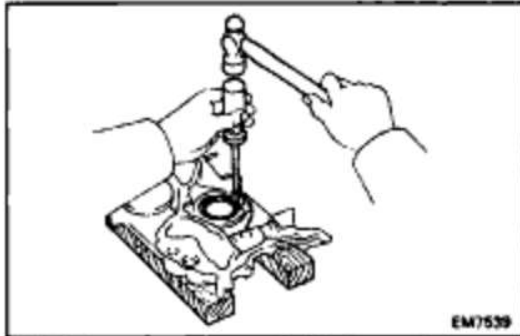

### 1. REPLACE CRANKSHAFT FRONT OIL SEAL

#### A. If oil pump is removed from cylinder block:

- (a) Using a screwdriver and a hammer, tap out the oil seal.

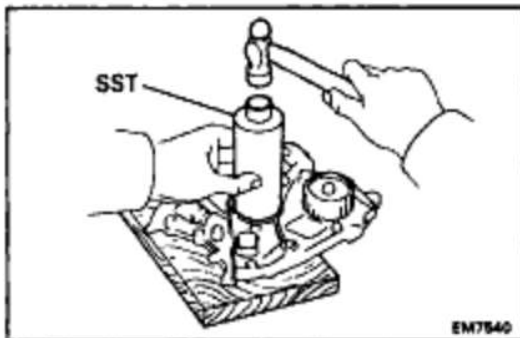

- (b) Using SST and a hammer, tap in a new oil seal until its surface is flush with the oil pump case edge.

SST 09223 - 63010

- (c) Apply MP grease to the oil seal lip.

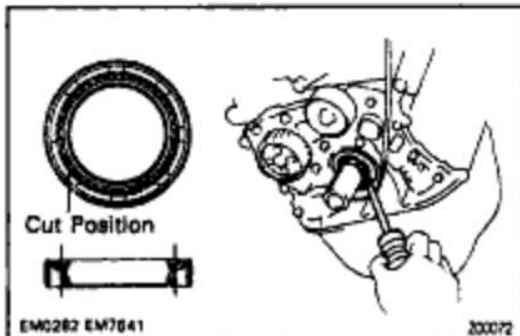

#### B. If oil pump is installed to the cylinder block:

- (a) Using a knife, cut off the oil seal lip.

- (b) Using a screwdriver, pry out the oil seal.

**NOTICE:** Be careful not to damage the crankshaft. Tape the screwdriver tip.

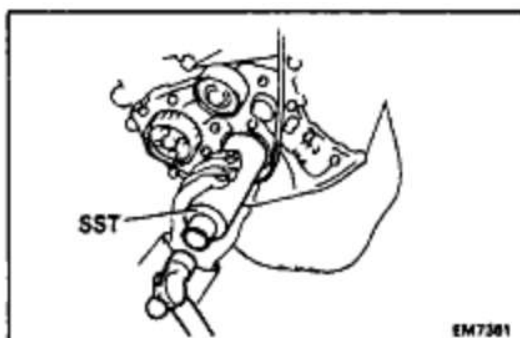

- (c) Apply MP grease to a new oil seal lip.

- (d) Using SST and a hammer, tap in the oil seal until its surface is flush with the oil pump case edge.

SST 09226 - 10010

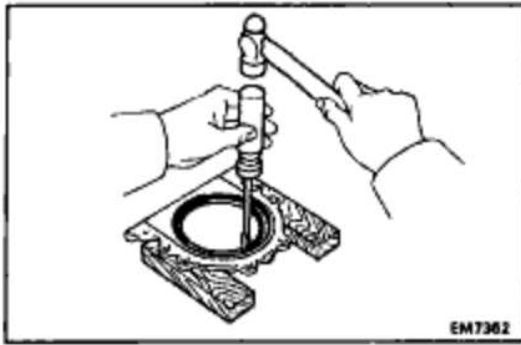

## 2. REPLACE CRANKSHAFT REAR OIL SEAL

### A. If rear oil seal retainer is removed from cylinder block:

(a) Using screwdriver and hammer, tap out the oil seal.

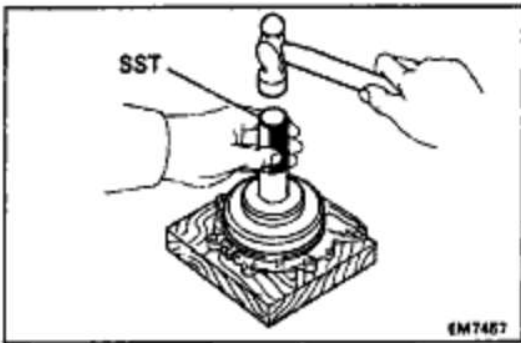

(b) Using SST and a hammer, tap in a new oil seal until its surface is flush with the rear oil seal edge.

SST 09223-63010

(c) Apply MP grease to the oil seal lip.

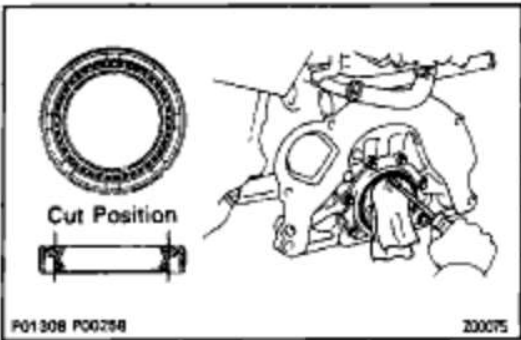

### B. If rear oil seal retainer is installed to cylinder block:

(a) Using a knife, cut off the oil seal lip.

(b) Using a screwdriver, pry out the oil seal.

**NOTICE:** Be careful not to damage the crankshaft. Tape the screwdriver tip.

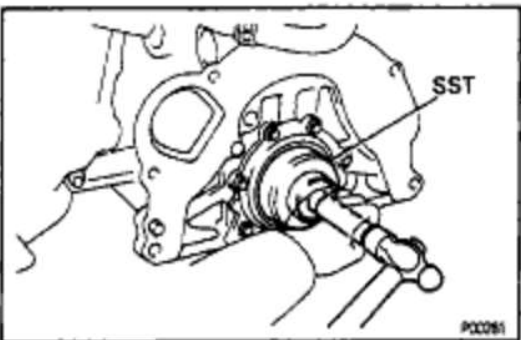

(c) Apply MP grease to a new oil seal lip.

(d) Using SST and a hammer, tap in the oil seal until its surface is flush with the rear oil seal retainer edge.

SST 09223 - 63010

## EG1-118

## 5S-FE ENGINE - ENGINE MECHANICAL

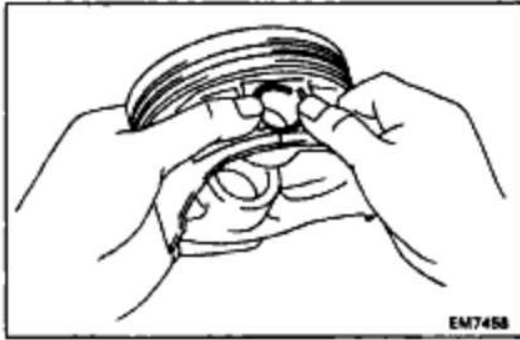

## PISTON AND CONNECTING ROD ASSEMBLY

### 1. ASSEMBLE PISTON AND CONNECTING ROD

- (a) Install a new snap ring on one side of the piston pin hole.

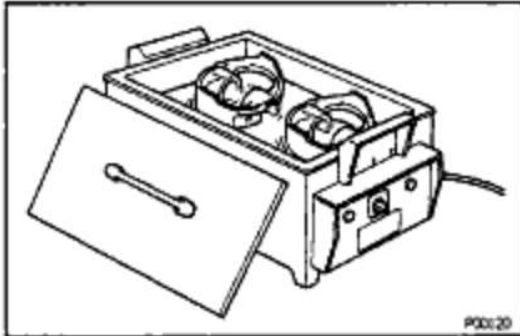

- (b) Gradually heat the piston to 80–90°C (176–194°F).

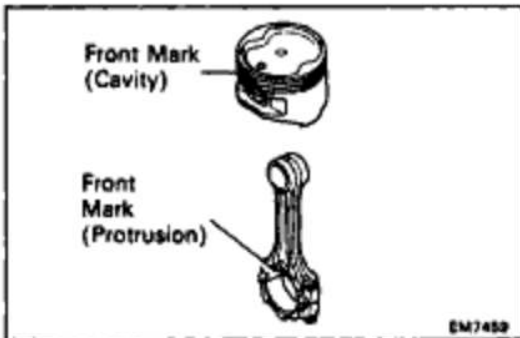

- (c) Coat the piston pin with engine oil.  
 (d) Align the front marks of the piston and connecting rod, and push in the piston pin with your thumb.



- (e) Install a new snap ring on the other side of the piston pin hole.



### 2. INSTALL PISTON RINGS

- (a) Install the oil ring expander and 2 side rails by hand.

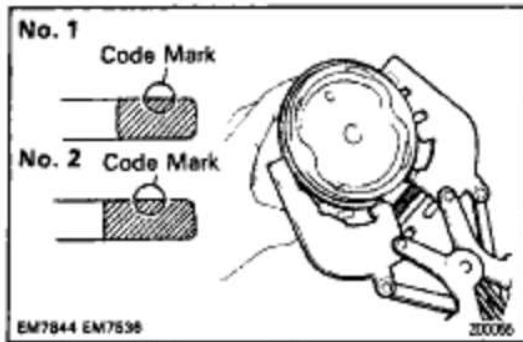

- (b) Using a piston ring expander, install the 2 compression rings with the code mark facing upward.

**Code mark:**

No.1

1N or T

No.2

2N or 2T

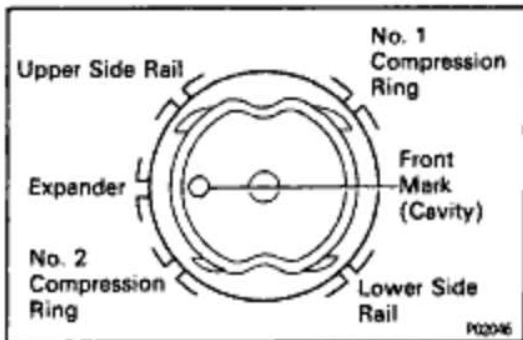

- (c) Position the piston rings so that the ring ends are as shown.

**NOTICE:** Do not align the ring ends.

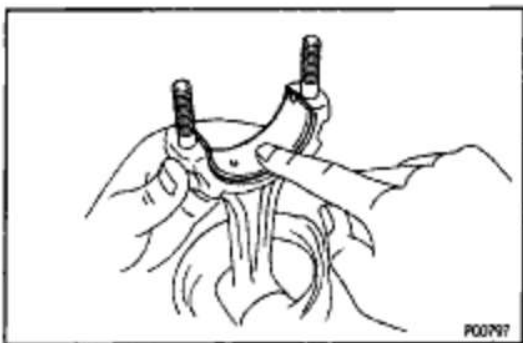

### 3. INSTALL BEARINGS

- (a) Align the bearing claw with the groove of the connecting rod or connecting cap.  
 (b) Install the bearings in the connecting rod and connecting rod cap.

## CYLINDER BLOCK ASSEMBLY

(See Components for Cylinder Block Disassembly and Assembly)

HINT:

- Thoroughly clean all parts to be assembled.
- Before installing the parts, apply new engine oil to all sliding and rotating surfaces.
- Replace all gaskets, O-rings and oil seals with new parts.

### 1. INSTALL MAIN BEARINGS

HINT:

- Main bearings come in widths of 19.2 mm (0.756 in.) and 22.9 mm (0.902 in.). Install the 22.9 mm (0.902 in.) bearings in the No.3 cylinder block journal position with the main bearing cap. Install the 19.2 mm (0.756 in.) bearings in the other positions.

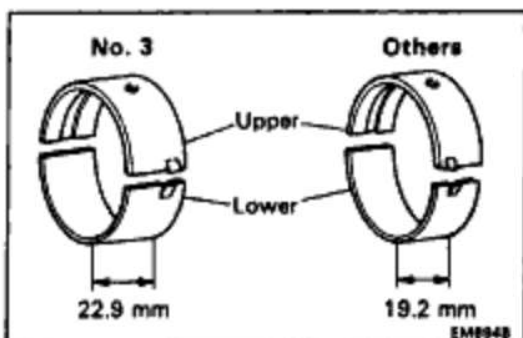

## EG1-120

## 5S-FE ENGINE - ENGINE MECHANICAL

- Upper bearings have an oil groove and oil holes; lower bearings do not.

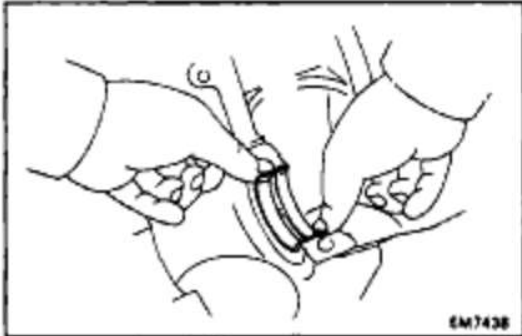

- (a) Align the bearing claw with the claw groove of the cylinder block, and push in the 5 upper bearings.

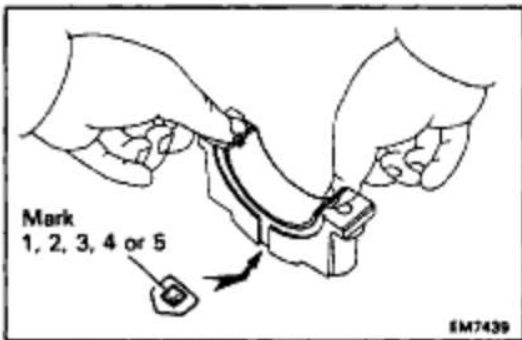

- (b) Align the bearing claw with the claw groove of the main bearing cap, and push in the 5 lower bearings.  
HINT: A number is marked on each main bearing cap to indicate the installation position.

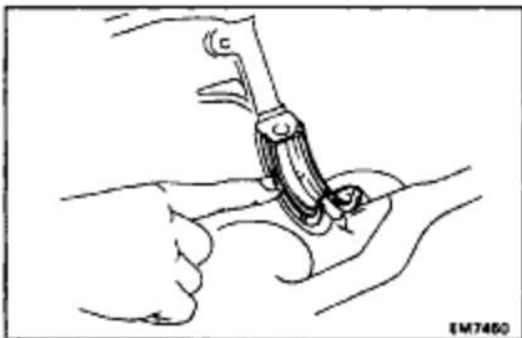

## 2. INSTALL UPPER THRUST WASHERS

Install the 2 thrust washers under the No.3 journal position of the cylinder block with the oil grooves facing outward.

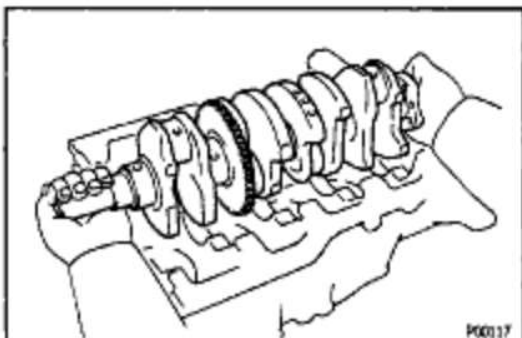

## 3. PLACE CRANKSHAFT ON CYLINDER BLOCK



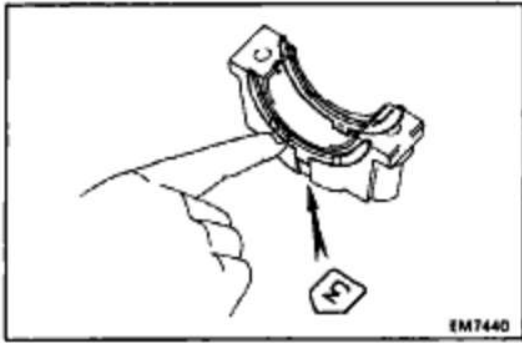

#### 4. INSTALL MAIN BEARING CAPS AND LOWER THRUST WASHERS

- (a) Install the 2 thrust washers on the No.3 bearing cap with the grooves facing outward.

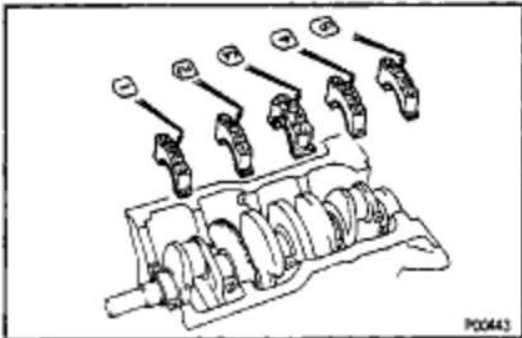

- (b) Install the 5 main bearing caps in their proper locations.

HINT: Each bearing cap has a number and front mark.

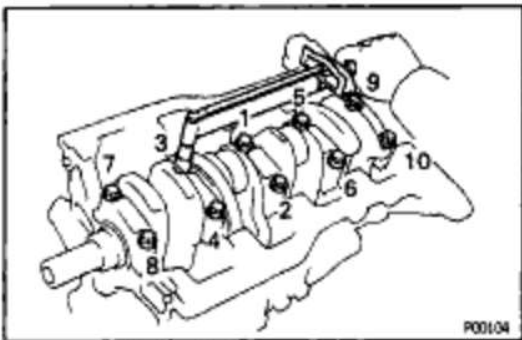

- (c) Apply a light coat of engine oil on the threads and under the heads of the main bearing cap bolts.  
 (d) Install and uniformly tighten the 10 bolts of the main bearing caps in several passes, in the sequence shown.

**Torque: 59 N-m (600 kgf-cm, 43 ft-lbf)**

- (e) Check that the crankshaft turns smoothly.

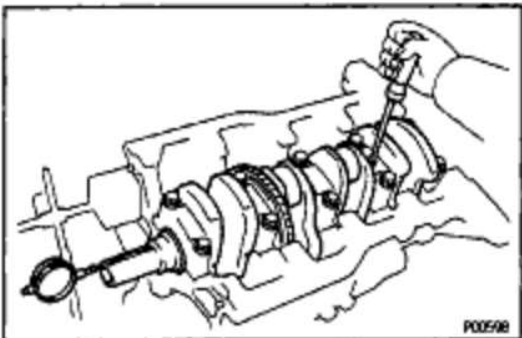

- (f) Check the crankshaft thrust clearance.

Using a dial indicator, measure the thrust clearance while prying the crankshaft back and forth with a screwdriver.

Standard thrust clearance:

0.020 – 0.220 mm (0.0008 – 0.0087 in.)

Maximum thrust clearance:

0.30 mm (0.0118 in.)

If the thrust clearance is greater than maximum, replace the thrust washers as a set.

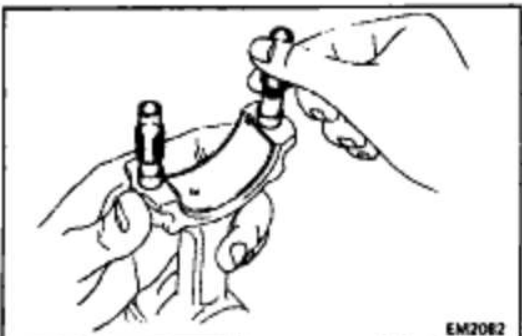

#### 5. INSTALL PISTON AND CONNECTING ROD ASSEMBLES

- (a) Cover the connecting rod bolts with a short piece of hose to protect the crankshaft from damage.

## EG1-122

## 5S-FE ENGINE - ENGINE MECHANICAL

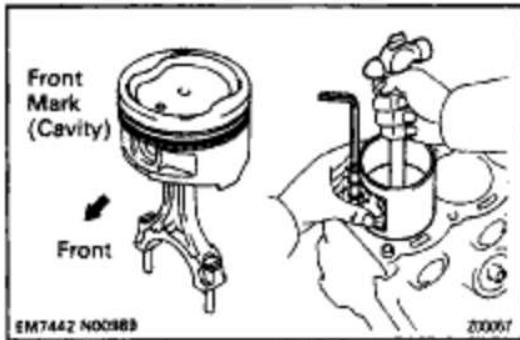

- (b) Using a piston ring compressor, push the correctly numbered piston and connecting rod assemblies into each cylinder with the front mark of the piston facing forward.

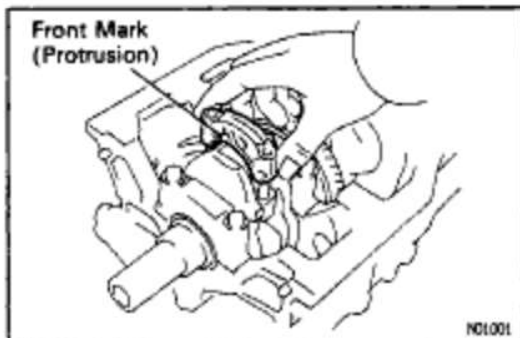
**6. INSTALL CONNECTING ROD CAPS****A. Place connecting rod cap on connecting rod**

- (a) Match the numbered connecting rod cap with the connecting rod.  
 (b) Install the connecting rod cap with the front mark facing forward.

**B. Install connecting rod cap nuts****HINT:**

The cap nuts are tightened in 2 progressive steps (steps

- (b) and  
 (d)).

If any one of the connecting rod bolts is broken or deformed, replace it.

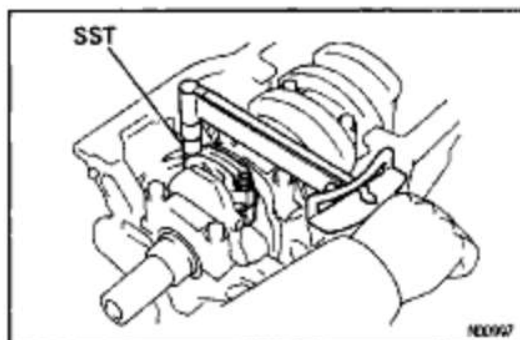

- (a) Apply a light of engine oil on the threads and under the nuts of the connecting rod cap.  
 (b) Using SST, install and alternately tighten the cap nuts in several passes.

SST 09011- 38121

**Torque: 25 N-m (250 kgf-cm, 18 ft-lbf)**

**If any one of the cap nuts does not meet the torque specification, replace the connecting rod bolt and cap nut as a set.**

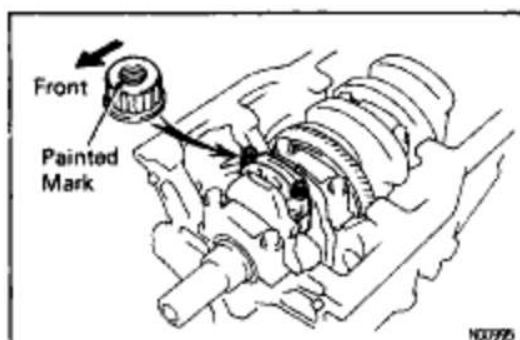

- (c) Mark the front of the cap nut with the paint.

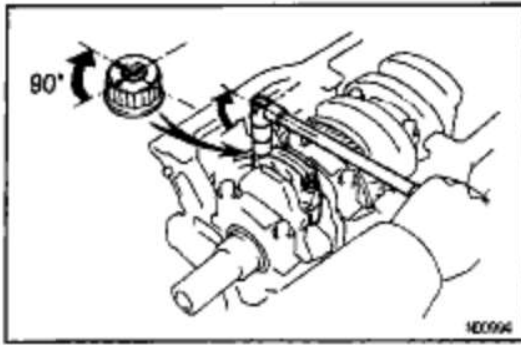

- (d) Retighten the cap nuts 90<sup>1</sup> as shown.
- (e) Check that the painted mark is now at a 90<sup>1</sup> angle to the front.
- (f) Check that the crankshaft turns smoothly.

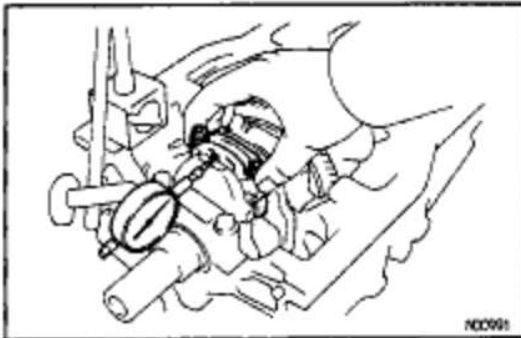

- (g) Check the connecting rod thrust clearance.  
Using a dial indicator, measure the thrust clearance while moving the connecting rod back and forth.  
Standard thrust clearance:  
0.160 – 0.312 mm (0.0063 – 0.0123 In.)  
Maximum thrust clearance:  
0.35 mm 10.0138 In.)  
If the thrust clearance is greater than maximum, replace the connecting rod assembly. If necessary, replace the crankshaft.

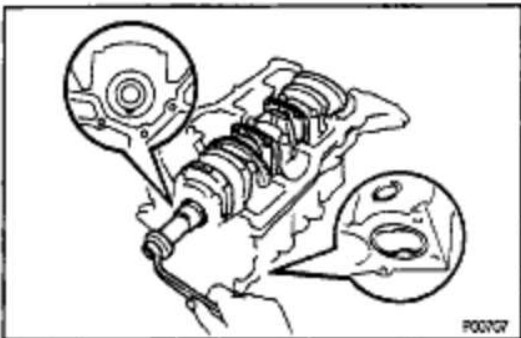

## 7. INSTALL ENGINE BALANCER

- (a) Turn the crankshaft, and set the No. 1 cylinder TDC as shown in the illustration.

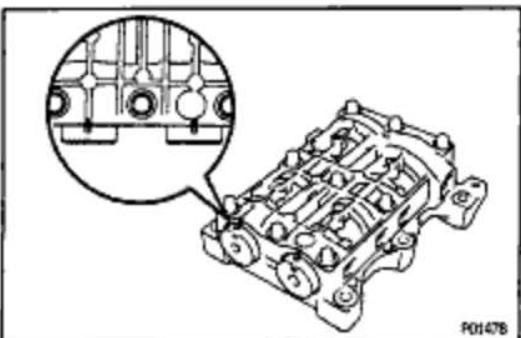

- (b) Set the balance shafts so that the punch marks of the balance shafts are aligned with the grooves of the No. 2 housing.

## EG1-124

## 5S-FE ENGINE - ENGINE MECHANICAL

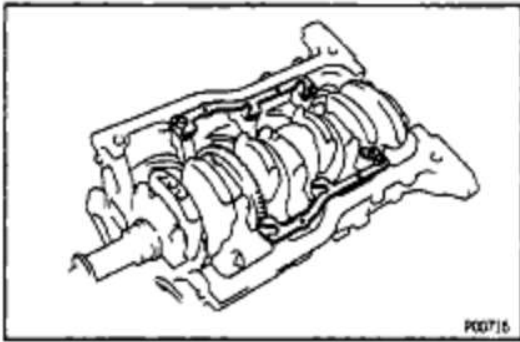

- (c) Wipe clean the installation surface of the spacer.  
 (d) Place the spacers on the cylinder block.  
 HINT: When replacing the crankshaft and/or balance shaft, use the thickest spacers.

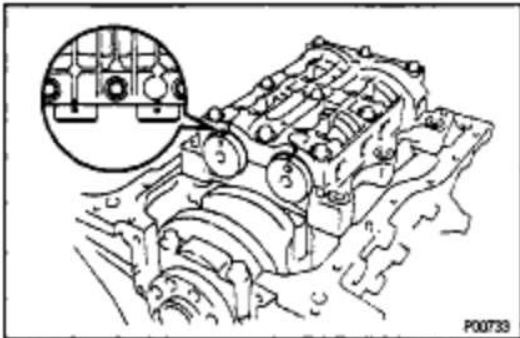

- (e) Place the engine balancer on the cylinder block.  
 (f) Check that punch marks shown in the illustration of the balance shafts are align with the grooves of the No.2 housing.

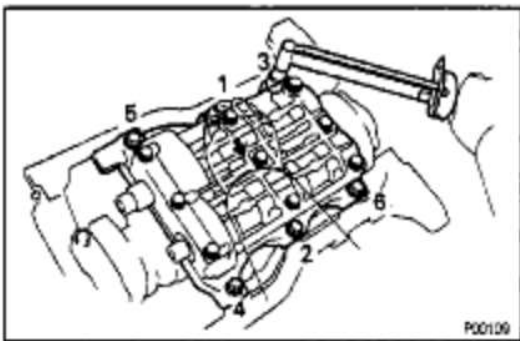

- (g) While pulling the center part of the engine balancer in the direction of the arrow, uniformly tighten the 6 bolts in several passes, in the sequence shown.  
 Torque: 49 N-m (500 kgf-cm, 36 ft-lbf)

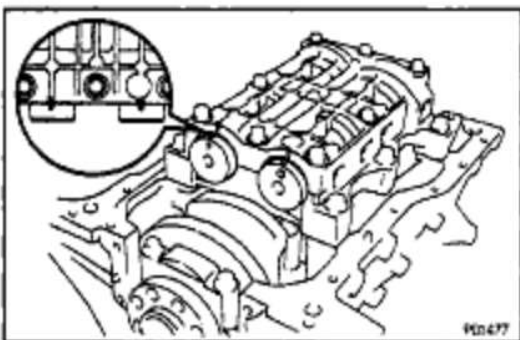

- (h) Recheck that the punch marks of the balance shafts are aligned with the grooves of No.2 housing.
- 8. CHECK AND ADJUST BACKLASH OF CRANKSHAFT GEAR AND NO.1 BALANCE SHAFT GEAR (See page EG1-94)**

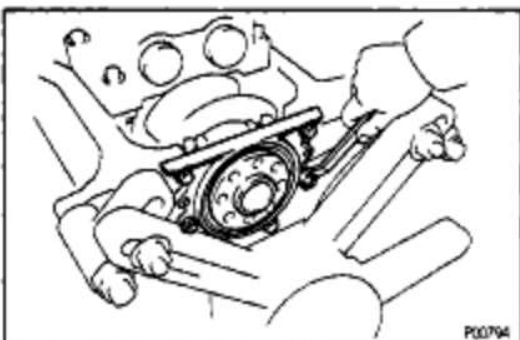

- 9. INSTALL REAR OIL SEAL RETAINER**  
 Install a new gasket and the retainer with the 6 bolts.  
 Torque: 9.3 N-m (95 kgf-cm, 82 in.-lbf)

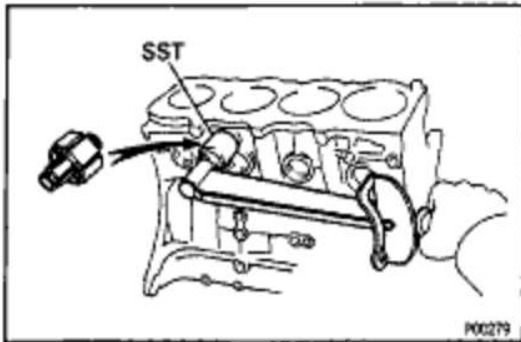

## POST ASSEMBLY

### 1. INSTALL KNOCK SENSOR

Using SST, install the knock sensor.  
SST 09816-30010

Torque: 37 N-m (380 kgf-cm, 27 ft-lbf)

### 2. w/ OIL COOLER:

#### INSTALL OIL COOLER

### 3. INSTALL OIL FILTER

### 4. INSTALL OIL PUMP AND OIL PAN

### 5. INSTALL WATER PUMP AND GENERATOR ADJUSTING BAR

### 6. INSTALL CYLINDER HEAD

### 7. INSTALL PULLEYS AND TIMING BELT



### 8. INSTALL PS PUMP BRACKET

Install the PS pump bracket with 3 bolts.

Torque: 43 N-m (440 kgf-cm, 32 ft-lbf)

### 9. INSTALL GENERATOR

### 10. INSTALL DISTRIBUTOR

### 11. REMOVE ENGINE STAND

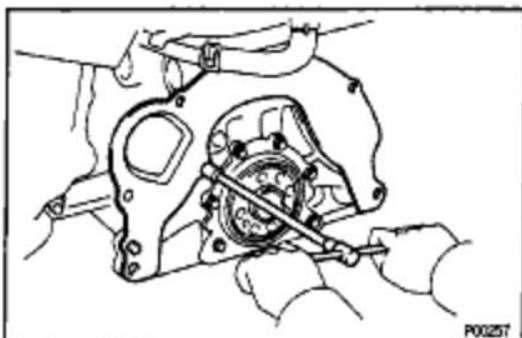

### 12. INSTALL REAR END PLATE

Torque: 9.3 N-m (95 kgf-cm, 82 in.-lbf)

## EG1-126

## 5S-FE ENGINE - ENGINE MECHANICAL

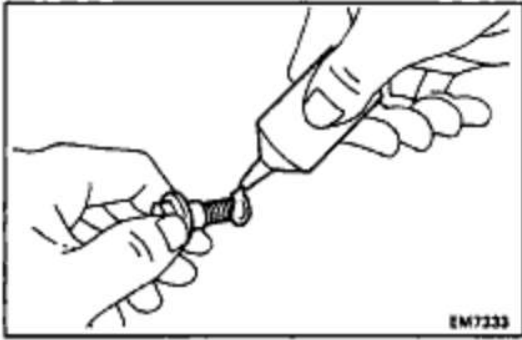

**13. M/T:**  
**INSTALL FLYWHEEL**

- (a) Apply adhesive to 2 or 3 threads of the mounting bolt end.

**Adhesive:**

**Part No.08833-00070. THREE BOND 1324 or equivalent**

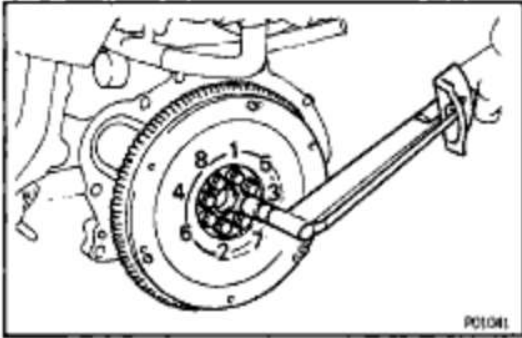

- (b) Install the flywheel on the crankshaft.  
 (c) install and uniformly tighten the mounting bolts in several passes, in the sequence shown.

**Torque: 88 N-m (900 kgf-cm, 66 ft-lbf)**

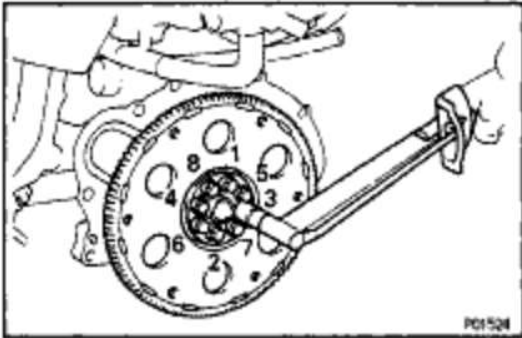

**14. A/T:**  
**INSTALL DRIVE PLATE (See procedure step 13)**

**Torque: 83 N-m (850 kgf-cm, 61 ft-lbf)**

**15. M/T:**  
**INSTALL CLUTCH DISC AND COVER**

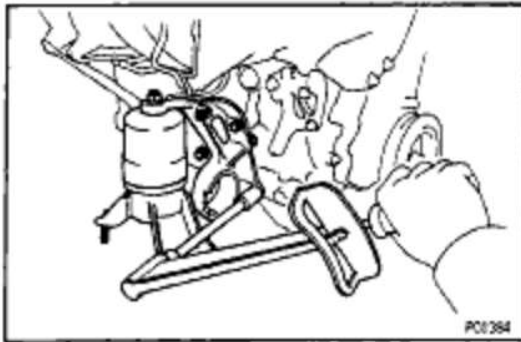

## ENGINE INSTALLATION

(See Components for Engine Removal and Installation)

### 1. INSTALL RR ENGINE MOUNTING INSULATOR

Install the mounting insulator with the 4 bolts.

Torque: 64 N-m (650 kgf-cm, 47 ft-lbf)

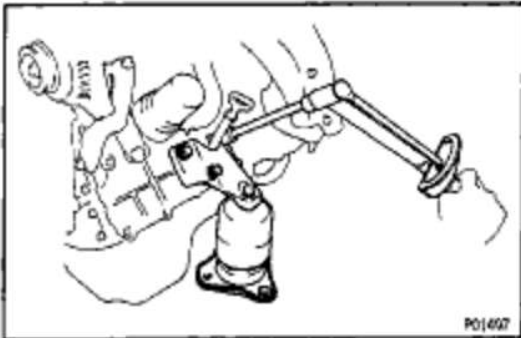

### 2. INSTALL FR ENGINE MOUNTING INSULATOR

(a) Install the mounting insulator with the 4 bolts.

Torque: 77 N-m (790 kgf-cm, 57 ft-lbf)

(b) Install the manifold stay with the bolt and nut.

Torque: 42 N-m (425 kgf-cm, 31 ft-lbf)

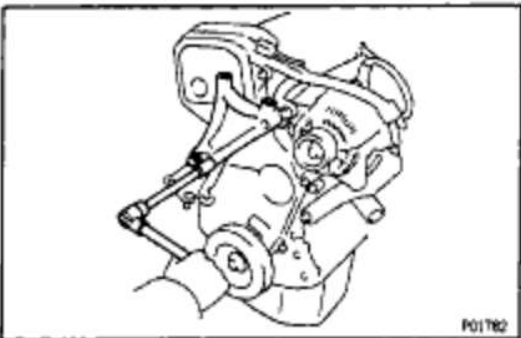

### 3. INSTALL NO.2 ENGINE MOUNTING BRACKET

(a) Temporarily install the No.2 engine mounting bracket with the 2 bolts.

(b) Install the remain bolt.

(c) Tighten the 3 bolts in the sequence shown.

Torque: 52 N-m (530 kgf-cm, 38 ft-lbf)

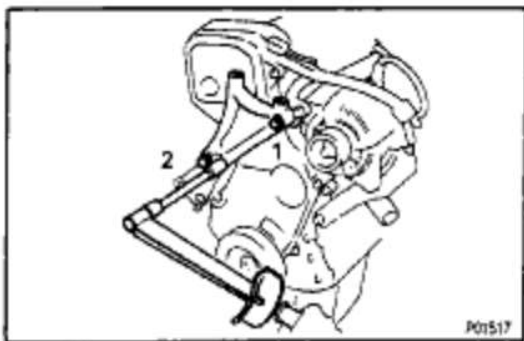

### 4. ASSEMBLE ENGINE AND TRANSAXLE

M/T (See page [MX-15](#))

A/T (See page [AX1-27](#))

5. A/T:

INSTALL STARTER

## EG1-128

## 5S-FE ENGINE - ENGINE MECHANICAL

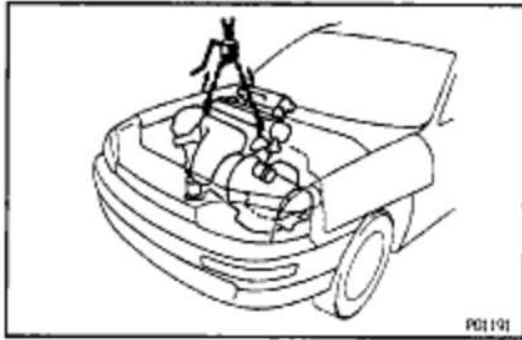

### 6. INSTALL ENGINE AND TRANSAXLE ASSEMBLY IN VEHICLE

- (a) Attach the engine sling device to the engine hangers.
- (b) Lower the engine into the engine compartment.  
Tilt the transaxle downward, lower the engine and clear the LH mounting.

**NOTICE:** Be careful not to hit the PS gear housing or park/neutral position switch (A/T).

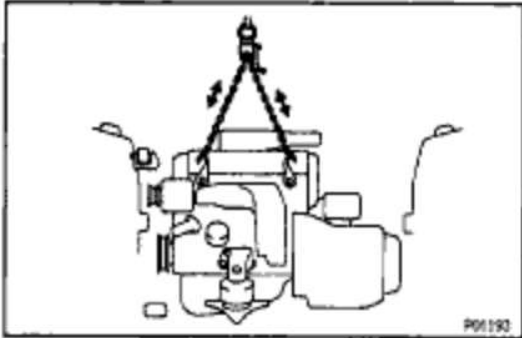

- (c) Keep the engine level, and align RH and LH mountings with the body bracket.

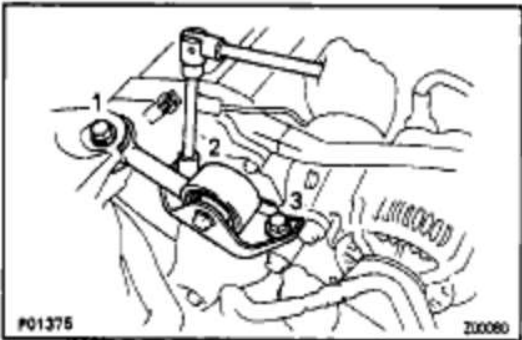

### 7. INSTALL ENGINE MOVING CONTROL ROD

- (a) Temporarily install the engine moving control rod with the 3 bolts in the sequence shown.

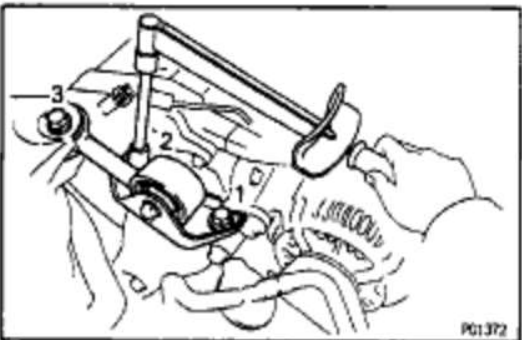

- (b) Tighten the 3 bolts in the sequence shown.  
**Torque: 64 N-m (650 kgf-cm, 47 ft-lbf)**

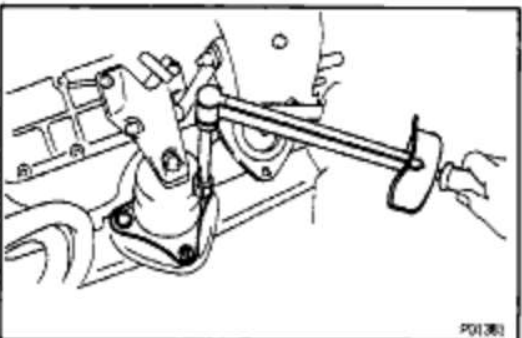

### 8. CONNECT FR ENGINE MOUNTING INSULATOR

Connect the mounting insulator with the 3 bolts.

**Torque: 80 N-m (820 kgf-cm, 59 ft-lbf)**

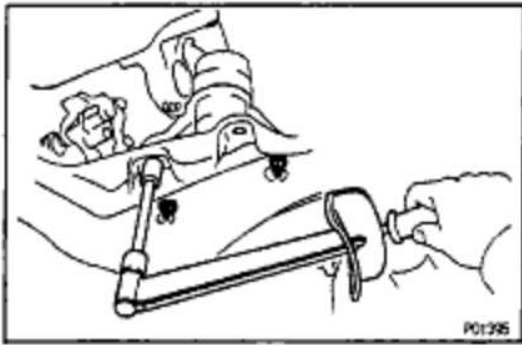

**9. CONNECT RR ENGINE MOUNTING INSULATOR**

(a) Connect the mounting insulator with the 3 nuts.

**Torque: 66 N-m (670 kgf-cm, 48 ft-lbf)**

(b) Install the hole plugs:

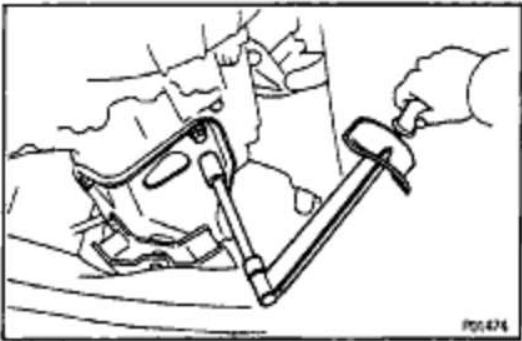
**10. CONNECT LH ENGINE MOUNTING INSULATOR**

M/T:

Connect the mounting insulator with the 3 bolts.

**Torque: 64 N-m (650 kgf-cm, 47 ft-lbf)**

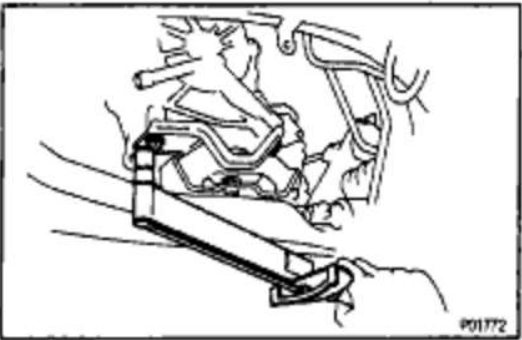

A/T:

Connect the mounting insulator with the 4 bolts.

**Torque: 64 N-m (650 kgf-cm, 47 ft-lbf)**

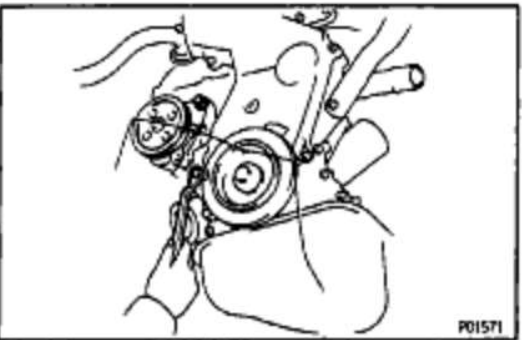
**11. REMOVE ENGINE SLING DEVICE****12. INSTALL PS PUMP**

(a) Install the PS pump with the 2 bolts.

**Torque: 43 N-m (440 kgf-cm, 31 ft-lbf)**

(b) Install the drive belt.

(c) Connect the 2 air hoses to the air pipe.

**13. INSTALL DRIVE SHAFTS**

(See page [SA-40](#))

## EG1-130

## 5S-FE ENGINE - ENGINE MECHANICAL

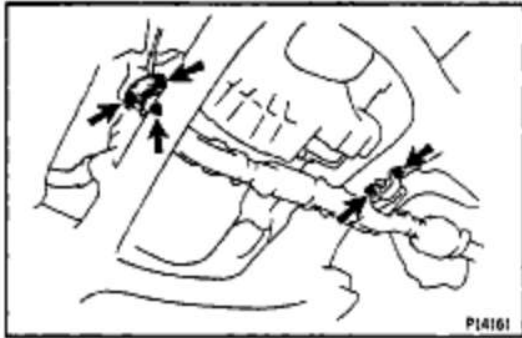
**14. CONNECT FRONT EXHAUST PIPE**

- (a) Place a new gasket on the front exhaust pipe.
- (b) Using a 14 mm deep socket wrench, install the 3 new nuts holding the front exhaust pipe to the WU-TWC.

**Torque: 82 N-m (630 kgf-cm, 46 ft-lbf)**

- (c) Install the bracket with the 2 bolts.

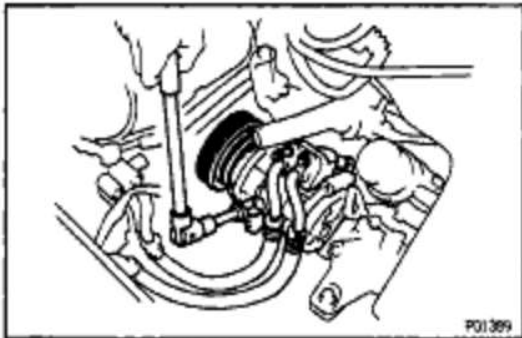
**15. w/ A/C:****INSTALL A/C COMPRESSOR**

- (a) Install the compressor with the 3 bolts.  
**Torque: 27 N-m (280 kgf-cm, 20 ft-lbf)**
- (b) Install the drive belt.
- (c) Connect the A/C compressor connector.

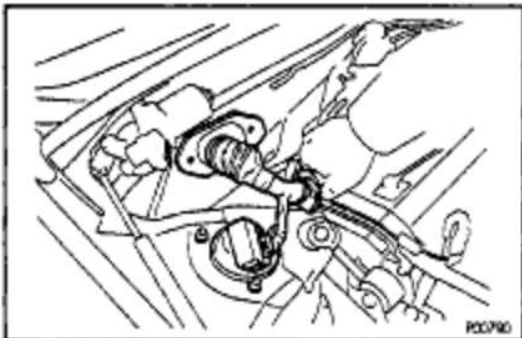
**16. CONNECT ENGINE WIRE TO CABIN**

- (a) Push in the engine wire through the cowl panel. Install the 2 nuts.
- (b) Connect the following connectors:
  - (1) 2 ECM connectors
  - (2) 2 cowl wire connectors
- (c) Install the glove compartment.
- (d) Install the glove compartment door.
- (e) Install the lower instrument panel.
- (f) Install the under cover.

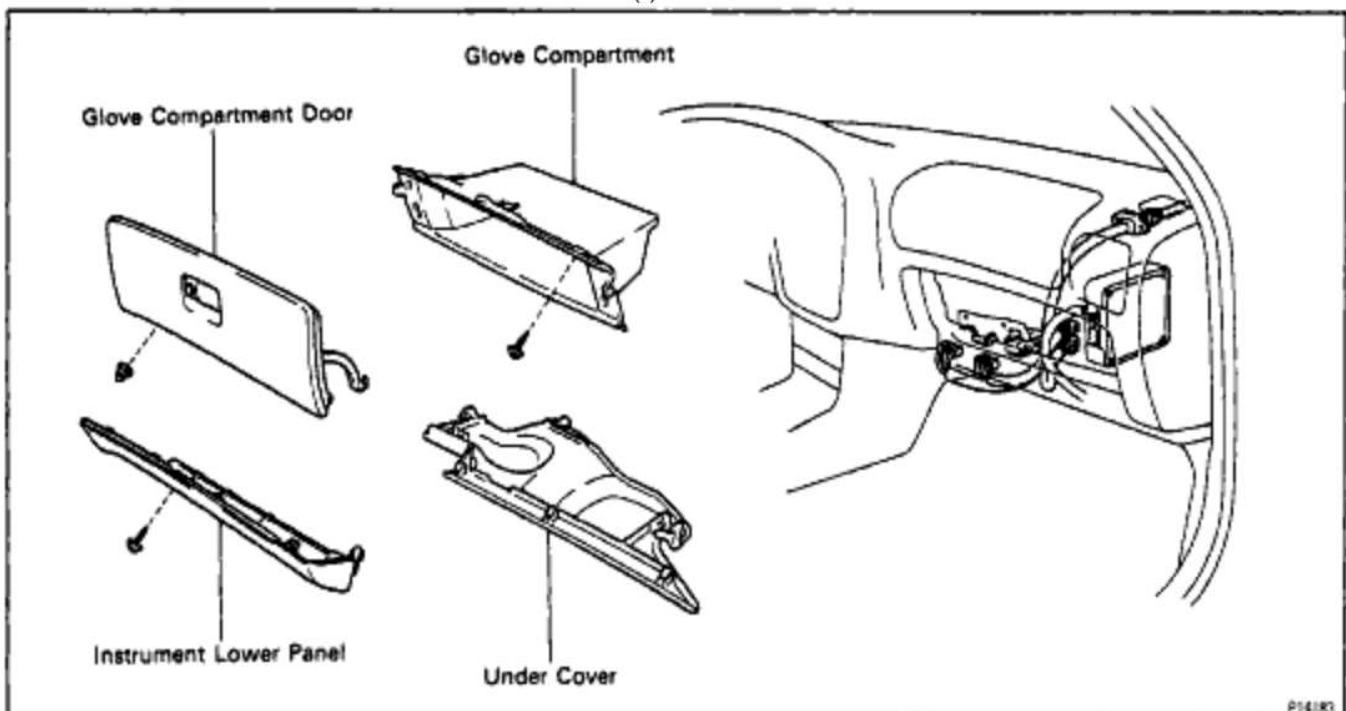

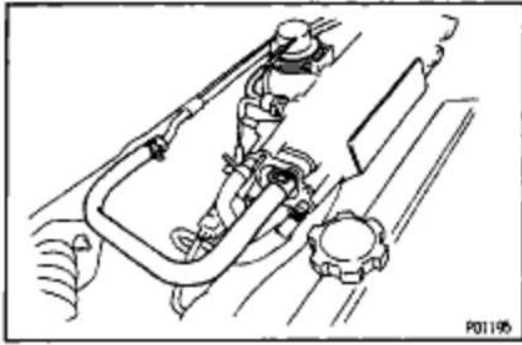
**17. CONNECT VACUUM HOSES**

- (a) MAP sensor hose to air intake chamber
- (b) Brake booster vacuum hose to air intake chamber

(c) Charcoal canister vacuum hose

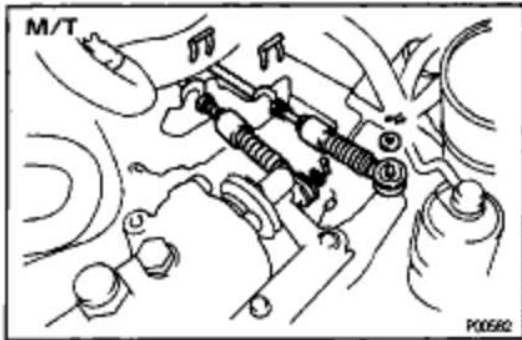
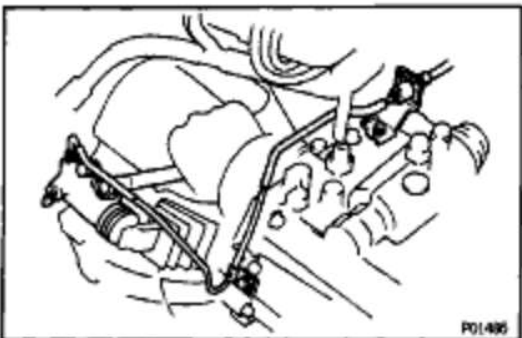
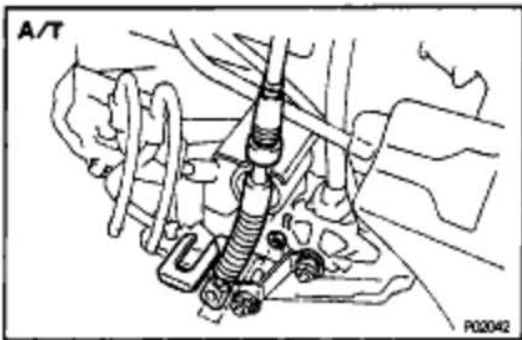
**18. CONNECT TRANSAXLE CONTROL CABLE (S) TO TRANSAXLE****19. M/T:****INSTALL CLUTCH RELEASE CYLINDER**

Install the release cylinder and tube with the 4 bolts.

**20. M/T:****INSTALL STARTER**

## EG1-132

## 5S-FE ENGINE - ENGINE MECHANICAL

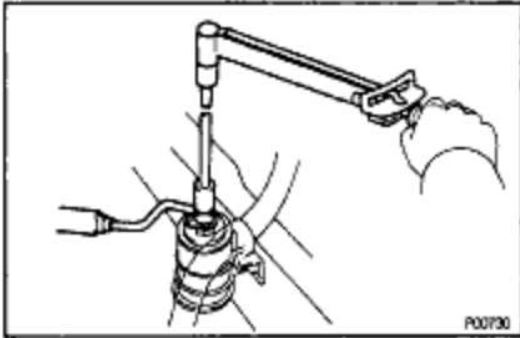
**21. CONNECT FUEL INLET HOSE**

Torque: 29 N-m (300 kgf-cm, 22 ft-lbf)

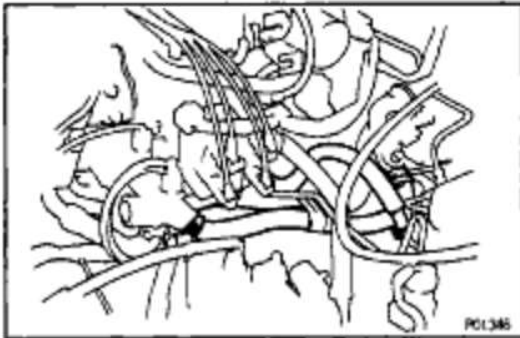
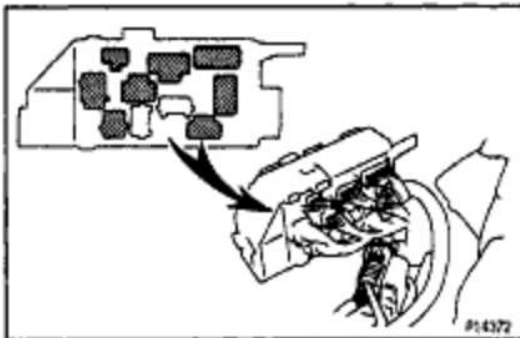
**22. CONNECT FUEL RETURN HOSE****23. CONNECT HEATER HOSES****24. CONNECT WIRES AND CONNECTORS**

- (a) Connect the 5 connectors to the relay box.
- (b) Connectors from LH fender apron.
- (c) Install the engine relay box.

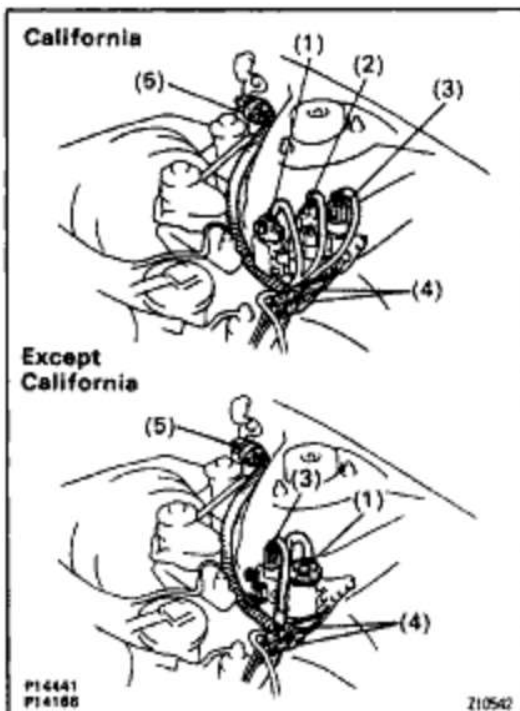

- (d) Connect the following connectors:

- (1) Igniter connector
- (2) California only:  
 Ignition coil connector
- (3) Noise filter connector
- (4) 2 ground straps from LH fender apron
- (5) Connector from LH fender apron

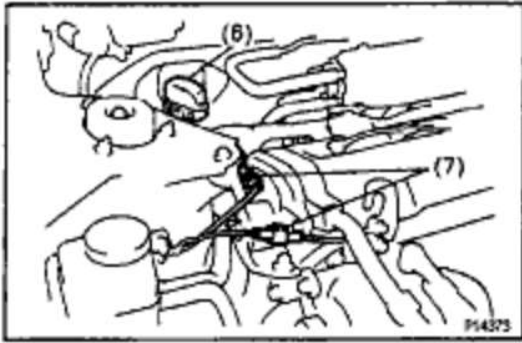

(6) Data link connector 1

(7) 2 ground straps from RH fender apron

(e) Connect the MAP sensor connector.

## 25. INSTALL RADIATOR

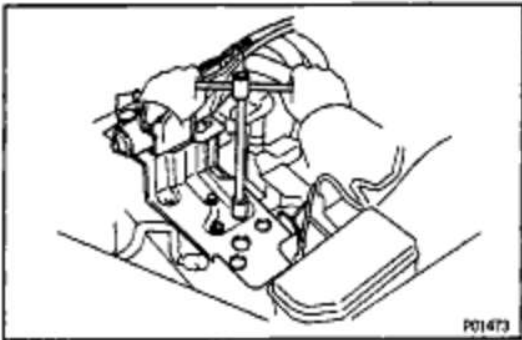

## 26. w/ CRUISE CONTROL SYSTEM:

### INSTALL CRUISE CONTROL ACTUATOR

(a) Install the actuator and bracket with the 3 bolts.

(b) Connect the actuator connector.

(c) Install the actuator cover.

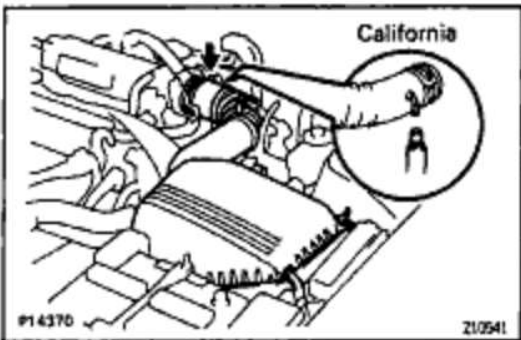

## 27. INSTALL AIR CLEANER ASSEMBLY, RESONATOR AND AIR CLEANER HOSE

(a) Install the air cleaner case with 3 bolts.

(b) Install the element.

(c) Connect the air cleaner hose to the throttle body.

(d) Install the air cleaner cap together with the resonator and air cleaner hose.

(e) California only:

Connect the air hose to the air cleaner hose.

(f) Connect the intake air temperature sensor connector.

## 28. A/T:

### CONNECT AND ADJUST THROTTLE CABLE

## 29. CONNECT AND ADJUST ACCELERATOR CABLE

## 30. FILL WITH ENGINE COOLANT

## 31. FILL WITH ENGINE OIL

## 32. CONNECT NEGATIVE (-) TERMINAL CABLE TO BATTERY

## 33. START ENGINE AND CHECK FOR LEAKS

## 34. PERFORM ENGINE ADJUSTMENT

## 35. INSTALL ENGINE UNDER COVERS

## 36. INSTALL HOOD

## 37. PERFORM ROAD TEST

Check for abnormal noises, shock, slippage, correct shift points and smooth operation.

## 38. RECHECK ENGINE COOLANT AND ENGINE OIL LEVELS

## EG1-134

## 5S-FE ENGINE - ENGINE MECHANICAL

ME170-04

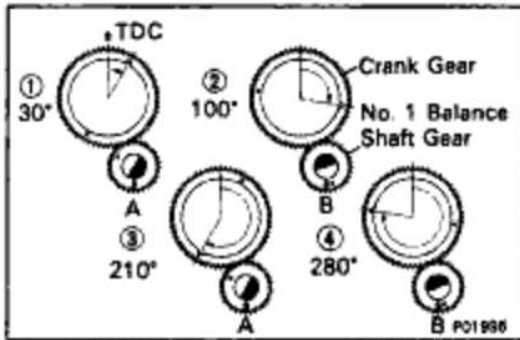

## BALANCE SHAFT BACKLASH ADJUSTMENT ON VEHICLE

### 1. CHECK BACKLASH OF CRANKSHAFT GEAR AND NO.1 BALANCE SHAFT GEAR

**NOTICE:** Backlash between the crankshaft gear and No.1 balance shaft gear varies with the rotation of the balance shaft and the deviation of the crankshaft gear.

Accordingly, it is necessary to measure the backlash at the 4 points shown in the illustration on the left.

- Rotate the crankshaft 2 or 3 times to settle the crankshaft gear and No. 1 balance shaft gear.
- When No.1 piston is at TDC, check that the punch marks C shown in the illustration of the balance shafts are aligned with the grooves of the No. 2 housing.

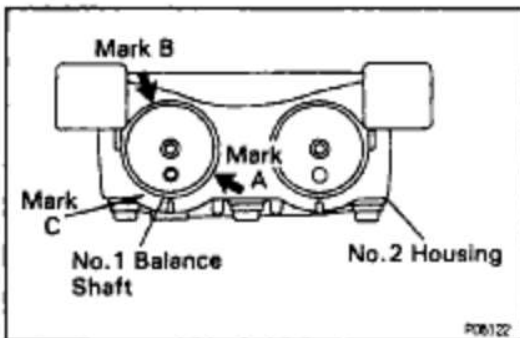
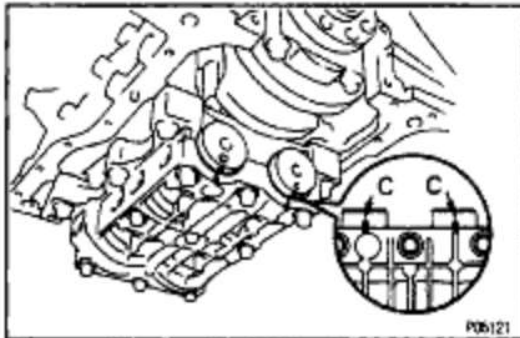

- Check that the punch marks A and B are at the positions on the No.1 balance shaft indicated in the illustration.

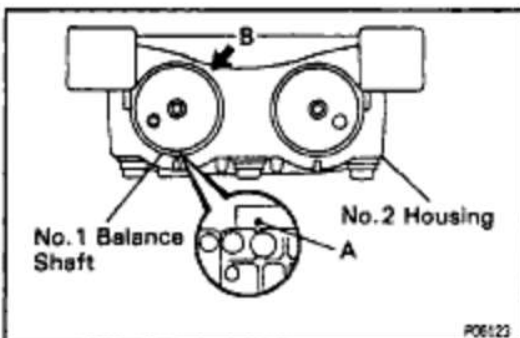

- First turn the crankshaft clockwise, and align the groove of the No.2 balance shaft housing with the punch mark A of the No. 1 balance shaft.

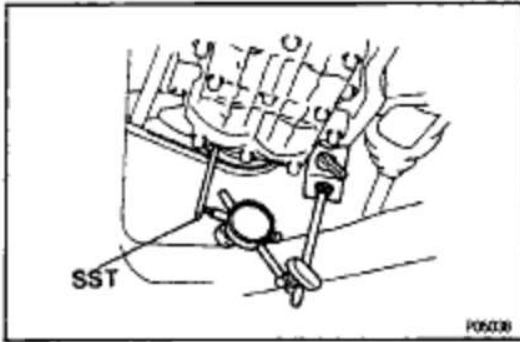

(e) Position the SST and dial indicator as shown in the illustration.

SST 09224 - 74010

HINT: Make sure that the stem of the dial indicator is perpendicular to the SST and that it is placed in the middle of the 3rd indentation.

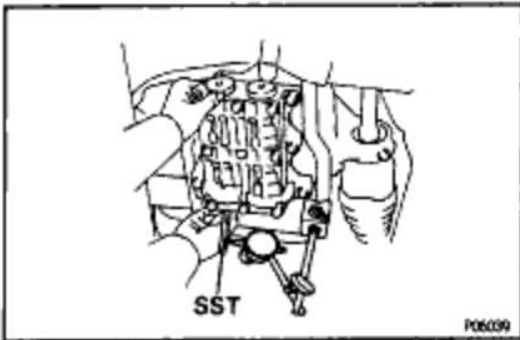
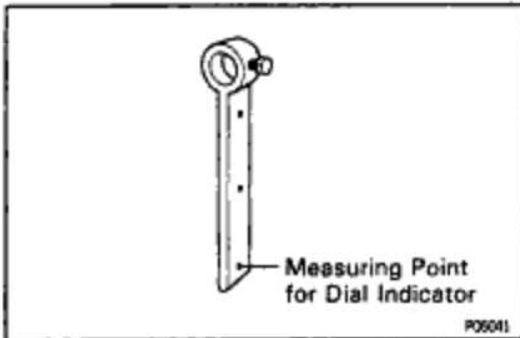

(f) Gently turn the No.1 balance shaft by hand, until resistance is felt, and measure the backlash.

HINT:

- Rotate the No. 1 balance shaft 4 or 5 times to provide a steady backlash reading.
- To prevent excessive backlash due to thrust clearance, measure the backlash while pressing on the rear of the No.1 balance shaft.

**Standard backlash (use SST):**

**0.060 - 0.100 mm (0.0024 - 0.0039 In.)**

**NOTICE: Do not turn the No.1 balance shaft strongly.**

(g) Remove the dial gauge and the SST.

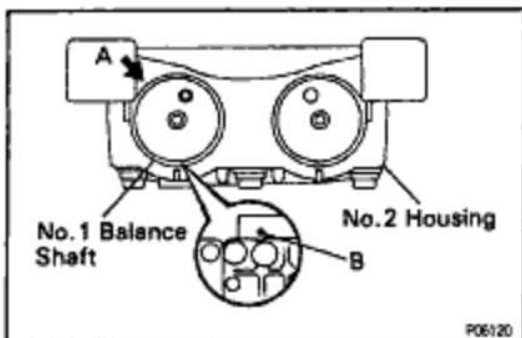

(h) Turn the crankshaft clockwise to align the groove of the No.2 housing with the punch mark B.

(i) Set the dial gauge. (See procedure in step (e))

(j) Measure the backlash. (See procedure in step (f))

**Standard backlash ( use SST ):**

**0.080 - 0.100 mm (0.0024 - 0.0039 in.)**

(k) Remove the dial gauge.

## EG1-136

## 5S-FE ENGINE - ENGINE MECHANICAL

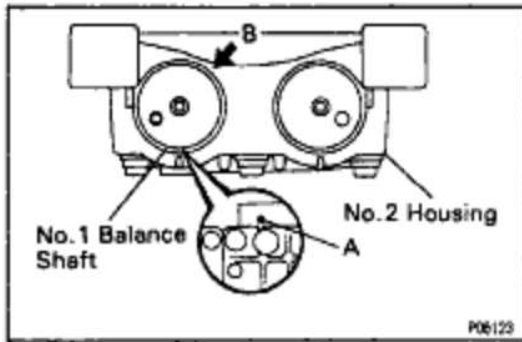

- (l) Turn the crankshaft clockwise again to align the groove of the No.2 housing with the punch mark A.  
 (m) Set the dial gauge. (See procedure in step (e))  
 (n) Measure the backlash. (See procedure in step (f))

**Standard backlash ( use SST ):**

**0.060 – 0.100 mm (0.0024 – 0.0039 in.)**

- (o) Remove the dial gauge.

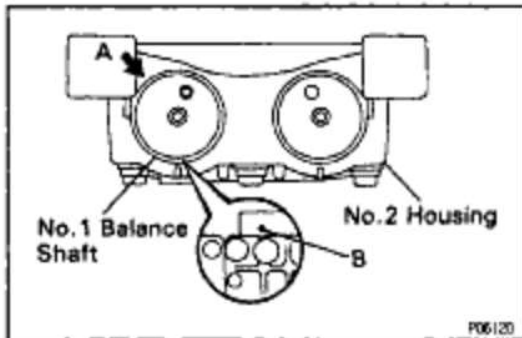

- (p) Turn the crankshaft clockwise again to align the groove of the No.2 housing with the punch mark B.  
 (q) Set the dial gauge. (See procedure in step (e))  
 (r) Measure the backlash. (See procedure in step (f))

**Standard backlash( use SST ):**

**0.06 – 0.100 mm (0.0024 – 0.0039 in.)**

- (s) Remove the dial gauge.

If even one of the 4 points measured above exceeds the backlash specification, adjust the backlash with new spacers.

**NOTICE: Use the same size spacers for both the left and right sides.**

**HINT:**

- Varying the spacer thickness by 0.02 mm (0.0008 in.) changes the backlash by about 0.042 mm (0.0017 in.).
- If the backlash is greater than permitted maximum, select a thinner shim.
- If the backlash is less than the specification, select a thicker shim.





## EG1-138

## 5S-FE ENGINE - ENGINE MECHANICAL

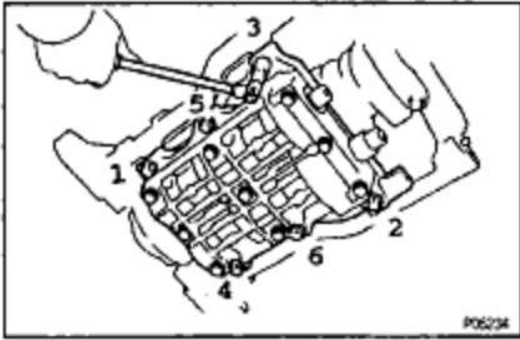
**2. REPLACE THE SPACERS**

- (a) Uniformly loosen the 6 bolts in the sequence shown.
- (b) Replace the spacers with new ones.

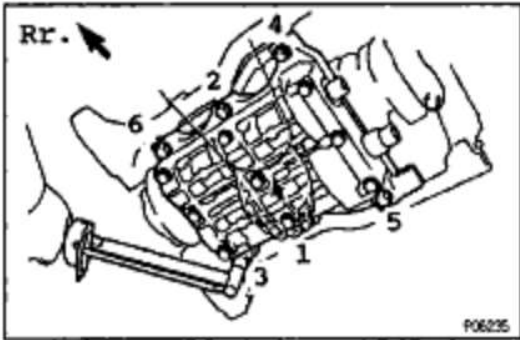
**3. TORQUE BALANCESHAFT ASSEMBLY**

While pulling the center part of the engine balancer in the direction of the arrow, uniformly tighten the 6 bolts in several passes, in the sequence shown.

**Torque: 49 N-m (500 kgf-cm, 36 ft-lbf)**

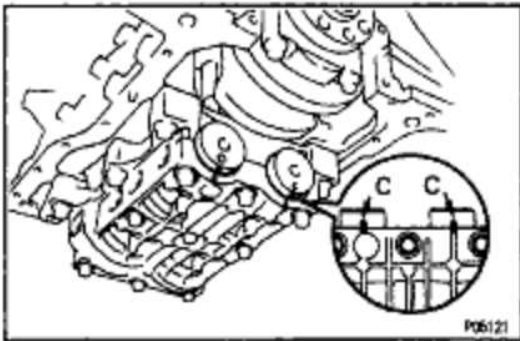

**4. CHECK AND ADJUST BACKLASH OF CRANK-SHAFT GEAR AND No.1 BALANCE SHAFT GEAR**  
(See procedure in step 1)

# EXHAUST SYSTEM COMPONENTS

W0001-01

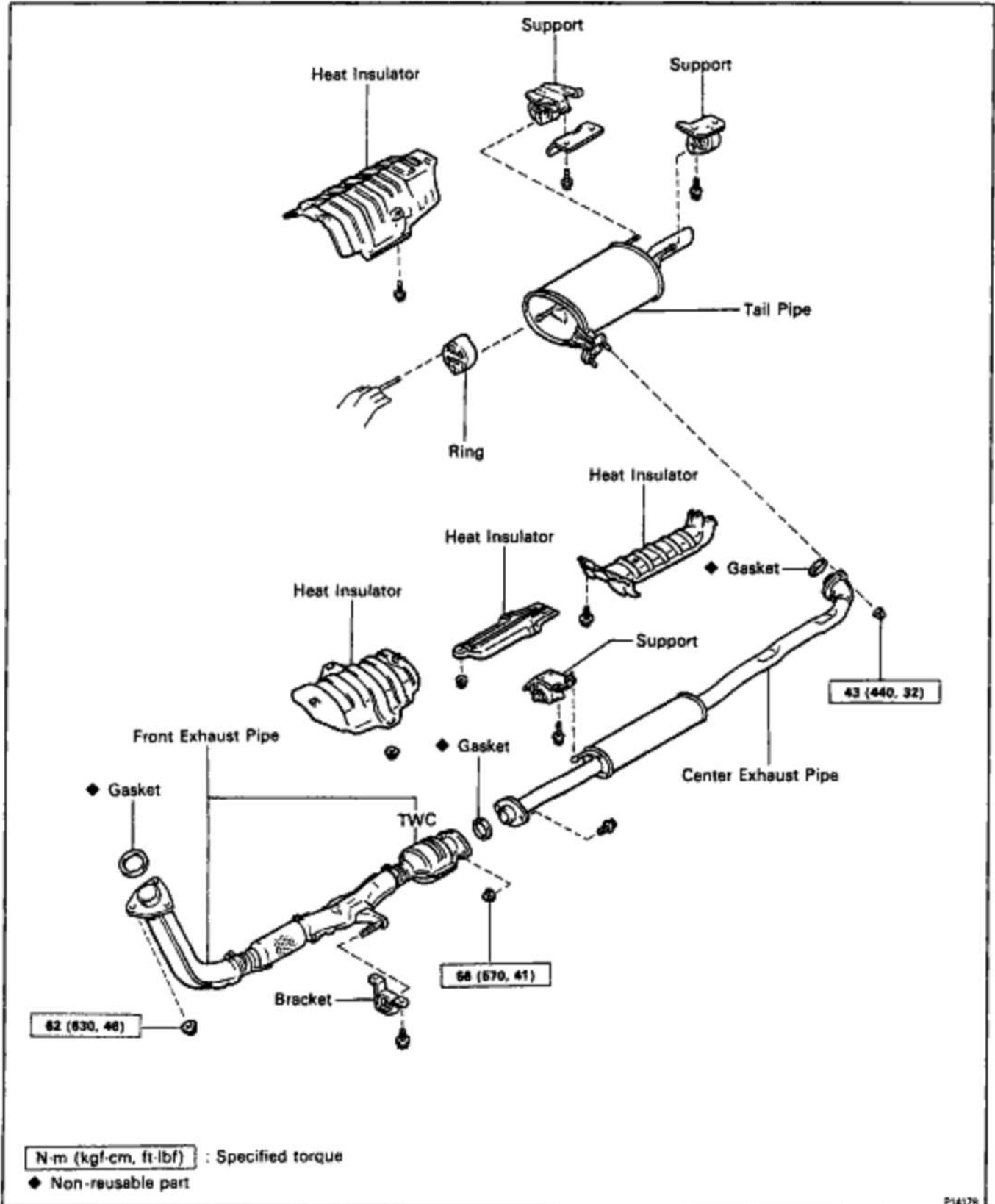

## EG1-140

## 5S-FE ENGINE - ENGINE MECHANICAL

# SERVICE SPECIFICATIONS

## SERVICE DATA

SERVICE

Idle speed	—		750 ± 50 rpm
Intake manifold vacuum	at idle speed		80 kPa (450 mmHg, 17.7 in.Hg)
Compression pressure	et 250 rpm	STD Limit	1,228 kPa (12.5 kgf/cm <sup>2</sup> , 178 psi) or more 981 kPa (10.0 kgf/cm <sup>2</sup> , 142 psi)
	Difference of pressure between each cylinder		98 kPa (1.0 kgf/cm <sup>2</sup> , 14 psi) or less
Idler pulley tension spring	Free length Installed load at 50.5 mm (1.988 in.)	Green color Silver color	46.0 mm (1.811 in.) 32 – 37 N (3.25 – 3.75 kgf, 7.2 – 8.3 lbf) 47 – 52 N (4.75 – 5.25 kgf, 10.5 – 11.6 lbf)
Cylinder head	Warpage Cylinder block side Manifold side Valve seat Refacing angle Contacting angle Contacting width	Limit Limit	0.05 mm (0.020 in.) 0.08 mm (0.031 in.)  30°, 45°, 75° 45° 1.0 – 1.4 mm (0.039 – 0.055 in.)
Valve guide bushing	Inside diameter Outside diameter (for repair part)	STD O/S 0.05	6.010 – 6.030 mm (0.2368 – 0.2374 in.) 11.048 – 11.059 mm (0.4350 – 0.4354 in.) 11.098 – 11.109 mm (0.4369 – 0.4374 in.)
Valve	Valve overall length  Vale face angle Stem diameter  Stem oil clearance  Margin thickness	STD (Intake) (Exhaust) Limit (Intake) (Exhaust)  (Intake) (Exhaust) STD (Intake) (Exhaust) Limit (Intake) (Exhaust) STD Limit	97.60 mm (3.8425 in.) 98.45 mm (3.8760 in.) 97.1 mm (3.823 in.) 96.0 mm (3.853 in.)  44.5° 5.970 – 5.985 mm (0.2350 – 0.2356 in.) 5.965 – 5.980 mm (0.2348 – 0.2354 in.) 0.025 – 0.060 mm (0.0010 – 0.0024 in.) 0.030 – 0.065 mm (0.0012 – 0.0026 in.) 0.08 mm (0.0031 in.) 0.10 mm (0.0039 in.) 0.8 – 1.2 mm (0.031 – 0.047 in.) 0.5 mm (0.020 in.)
Valve spring	Deviation Free length Installed tension et 34.7 mm (1.366 in.)	Limit	2.0 mm (0.079 in.) 41.96 – 41.99 mm (1.6520 – 1.6531 in.) 164 – 189 N (16.7 – 19.3 kgf, 36.8 – 42.5 lbf)
Valve lifter	Lifter diameter Lifter bore diameter Oil clearance	STD Limit	30.966 – 30.978 mm (1.2191 – 1.2195 in.) 31.000 – 31.018 mm (1.2205 – 1.2213 in.) 0.024 – 0.052 mm (0.0009 – 0.0020 in.) 0.07 mm (0.0028 in.)
Manifold	Warpage	Limit	0.30 mm (0.0118 in.)

## 5S-FE ENGINE - ENGINE MECHANICAL

Camshaft	Thrust clearance	STD (Intake)	0.045 - 0.100 mm (0.0018 - 0.0039 in.)
		(Exhaust)	0.030 - 0.085 mm (0.0012 - 0.0033 in.)
	Limit (Intake)	0.12 mm (0.0047 in.)	
		(Exhaust)	0.10 mm (0.0039 in.)
	Journal oil clearance	STD	0.025 - 0.062 mm (0.0010 - 0.0024 in.)
		Limit	0.10 mm (0.0039 in.)
	Journal diameter	Limit	28.959 - 28.975 mm (1.0814 - 1.0620 in.)
		Circle runout	0.04 mm (0.0018 in.)
	Cam lobe height	STD (Intake)	42.01 - 42.11 mm (1.6539 - 1.6579 in.)
		(Exhaust)	40.06 - 40.16 mm (1.5772 - 1.5811 in.)
	Limit (Intake)	41.90 mm (1.6496 in.)	
(Exhaust)		39.95 mm (1.5728 in.)	
Camshaft gear backlash	STD	0.020 - 0.200 mm (0.0008 - 0.0079 in.)	
	Limit	0.30 mm (0.0118 in.)	
Camshaft gear spring end free distance		22.5 - 22.9 mm (0.886 - 0.902 in.)	
Cylinder block	Cylinder head surface warpage	Limit	0.05 mm (0.0020 in.)
		Cylinder bore diameter	
	STD (Mark 1)	87.000 - 87.010 mm (3.4252 - 3.4258 in.)	
	(Mark 2)	87.010 - 87.020 mm (3.4258 - 3.4264 in.)	
	(Mark 3)	87.020 - 87.030 mm (3.4264 - 3.4264 in.)	
Limit (STD)	87.23 mm (3.4342 in.)		
(O/S 0.50)	87.73 mm (3.4350 in.)		
Piston and piston ring	Piston diameter	STD (Mark 1)	86.850 - 86.860 mm (3.4193 - 3.4197 in.)
		(Mark 2)	86.860 - 86.870 mm (3.4197 - 3.4201 in.)
		(Mark 3)	86.870 - 86.880 mm (3.4201 - 3.4205 in.)
		O/S 0.50	87.350 - 87.380 mm (3.4389 - 3.4402 in.)
	Piston oil clearance	STD	0.14 - 0.018 mm (0.0055 - 0.0063 in.)
		Limit	0.18 mm (0.0071 in.)
	Piston ring groove clearance	No.1	0.040 - 0.080 mm (0.0016 - 0.0031 in.)
		No.2	0.030 - 0.070 mm (0.0012 - 0.0028 in.)
	Piston ring end gap	STD (No.1)	0.270 - 0.500 mm (0.0106 - 0.0197 in.)
		(No.2)	0.350 - 0.600 mm (0.0138 - 0.0234 in.)
		(Oil)	0.200 - 0.550 mm (0.0079 - 0.0217 in.)
		Limit (No.1)	1.10 mm (0.0433 in.)
	(No.2)	1.20 mm (0.0472 in.)	
	(Oil)	1.15 mm (0.0453 in.)	

## EG1-142

## 5S-FE ENGINE - ENGINE MECHANICAL

Connecting rod	Thrust clearance	STD	0.180 - 0.312 mm (0.0063 - 0.0123 in.)
		Limit	0.35 mm (0.0138 in.)
	Connecting rod bearing center wall thickness (Reference)	STD (Mark 1)	1.484 - 1.488 mm (0.0584 - 0.0588 in.)
		(Mark 2)	1.488 - 1.492 mm (0.0588 - 0.0592 in.)
		(Mark 3)	1.492 - 1.496 mm (0.0592 - 0.0596 in.)
	Connecting rod oil clearance	STD (STD)	0.024 - 0.055 mm (0.0009 - 0.0022 in.)
		(U/S 0.25)	0.023 - 0.088 mm (0.0009 - 0.0027 in.)
		Limit	0.08 mm (0.0031 in.)
	Rod bend	Limit per 100 mm (3.94 in.)	0.05 mm (0.0020 in.)
	Rod twist	Limit per 100 mm (3.94 in.)	0.15 mm (0.0059 in.)
	Bushing inside diameter		22.005 - 22.017 mm (0.8683 - 0.8688 in.)
	Piston pin diameter		21.997 - 22.009 mm (0.8680 - 0.8685 in.)
	Piston pin oil clearance		0.005 - 0.011 mm (0.0002 - 0.0004 in.)
	Connecting rod bolt outside diameter	STD	0.05 mm (0.0020 in.)
	Limit	7.860 - 8.000 mm (0.3094 - 0.3150 in.)	
	STD	7.60 mm (0.2992 in.)	
	Limit		
Crankshaft	Thrust clearance	STD	0.020 - 0.220 mm (0.0008 - 0.0087 in.)
		Limit	0.30 mm (0.0118 in.)
	Thrust washer thickness		2.440 - 2.490 mm (0.0961 - 0.0980 in.)
	Main journal oil clearance	STD (No.3 STD)	0.025 - 0.044 mm (0.0010 - 0.0017 in.)
		(No.3 U/S 0.25)	0.027 - 0.067 mm (0.0011 - 0.0026 in.)
		(Others STD)	0.015 - 0.034 mm (0.0008 - 0.0013 in.)
		(Others U/S 0.25)	0.018 - 0.059 mm (0.0007 - 0.0023 in.)
		Limit	0.08 mm (0.0031 in.)
	Main journal diameter	STD	54.888 - 55.003 mm (2.1653 - 2.1655 in.)
		U/S 0.25	54.745 - 54.755 mm (2.1553 - 2.1557 in.)
	Main bearing center wall thickness (Reference)	STD (No.3 Mark 1)	1.992 - 1.995 mm (0.0784 - 0.0785 in.)
		(No.3 Mark 2)	1.995 - 1.998 mm (0.0785 - 0.0787 in.)
		(No.3 Mark 3)	1.998 - 2.001 mm (0.0787 - 0.0788 in.)
		(No.3 Mark 4)	2.001 - 2.004 mm (0.0788 - 0.0789 in.)
		(No.3 Mark 5)	2.004 - 2.007 mm (0.0789 - 0.0790 in.)
		(Others Mark 1)	1.997 - 2.000 mm (0.0788 - 0.0787 in.)
		(Others Mark 2)	2.000 - 2.003 mm (0.0787 - 0.0789 in.)
		(Others Mark 3)	2.003 - 2.006 mm (0.0789 - 0.0790 in.)
		(Others Mark 4)	2.006 - 2.009 mm (0.0790 - 0.0791 in.)
		(Others Mark 5)	2.009 - 2.012 mm (0.0791 - 0.0792 in.)
	Crank pin diameter	STD	51.985 - 52.000 mm (2.0468 - 2.0472 in.)
	U/S 0.25	51.745 - 51.755 mm (2.0372 - 2.0376 in.)	
Circle runout	Limit	0.08 mm (0.0024 in.)	
Main journal taper and out-of-round	Limit	0.02 mm (0.0008 in.)	
Crank pin taper and out-of-round	Limit	0.02 mm (0.0008 in.)	

## 5S-FE ENGINE - ENGINE MECHANICAL

Engine balancer	Thrust clearance	STD	0.065 - 0.110 mm (0.0026 - 0.0043 in.)
		Limit	0.110 mm (0.0043 in.)
	Backlash		
	Crankshaft x No. 1 balance shaft		
	Off-vehicle		
	On-vehicle	STD	0 - 0.06 mm (0 - 0.0024 in.)
	No. 1 balance shaft x No.2 balance shaft	STD	0.025 - 0.090 mm (0.0010 - 0.0035 in.)
	at D mark		
	at E mark	STD	0.020 - 0.075 mm (0.0008 - 0.0030 in.)
	at F mark	STD	0.005 - 0.075 mm (0.0002 - 0.0030 in.)
	Spacer thickness	STD	0.005 - 0.055 mm (0.0002 - 0.0022 in.)
		No.01	1.74 mm (0.0685 in.)
		No.03	1.76 mm (0.0693 in.)
		No.05	1.78 mm (0.0701 in.)
		No.07	1.80 mm (0.0709 in.)
		No.09	1.82 mm (0.0717 in.)
		No.11	1.84 mm (0.0724 in.)
		No.13	1.86 mm (0.0732 in.)
		No.15	1.88 mm (0.0740 in.)
		No.17	1.90 mm (0.0748 in.)
		No.19	1.92 mm (0.0756 in.)
		No.21	1.94 mm (0.0764 in.)
		No.23	1.96 mm (0.0772 in.)
		No.25	1.98 mm (0.0780 in.)
		No.27	2.00 mm (0.0787 in.)
		No.29	2.02 mm (0.0795 in.)
		No.31	2.04 mm (0.0803 in.)
		No.33	2.06 mm (0.0811 in.)
		No.35	2.08 mm (0.0819 in.)
		No.37	2.10 mm (0.0827 in.)
		No.39	2.12 mm (0.0835 in.)
	Balance shaft housing bolt outer diameter	STD	6.5 - 6.7 mm (0.2559 - 0.2638 in.)
		Limit	6.3 mm (0.2480 in.)

## TORQUE SPECIFICATIONS

M9001-00

Part tightened	N-m	kgf-cm	ft-lbf
Cylinder head cover x Cylinder head	23	230	17
Spark plug x Cylinder head	18	180	13
Oil pump pulley x Oil pump drive shaft	28	290	21
No. 2 idler pulley x Cylinder block	42	425	31
Crankshaft pulley x Crankshaft	108	1,100	80
Camshaft timing pulley x Camshaft	54	550	40
Camshaft timing pulley x Camshaft (For use with SST)	37	390	27
No. 1 idler pulley x Cylinder head	42	425	31
No. 2 engine mounting bracket x Cylinder block	52	530	38
Engine moving control rod X Fender apron	64	650	47
Engine moving control rod x No. 2 engine mounting bracket	64	650	47
Cylinder head x Cylinder block (1 sty	49	500	36

**EG1-144****5S-FE ENGINE – ENGINE MECHANICAL**

Cylinder head x Cylinder block (2nd)	Turn 90°		
Spark plug tube x Cylinder head	39	400	29
Camshaft bearing cap x Cylinder head	19	190	14
Generator bracket x Cylinder head	42	425	31
Engine hanger x Cylinder head	25	250	18
No. 3 timing belt cover x Cylinder head	7.8	80	69 in.-lbf
Delivery pipe x Cylinder head	13	130	9
Pulsation damper x Delivery pipe	34	350	25
Intake manifold x Cylinder head	19	195	14
Intake manifold stay x Intake manifold	22	220	16
Intake manifold stay x Cylinder block	42	425	31
No. 1 air intake chamber stay x Intake manifold	42	425	31
No. 1 air intake chamber stay x Cylinder head	42	425	31
EGR valve x intake manifold	13	130	9
EGR pipe x Cylinder head	59	600	43
Throttle body x Intake manifold	19	195	14
Water bypass pipe x Water pump cover	8.8	90	78 in.-lbf
Water outlet x Cylinder head	15	150	11
WU-TWC x Exhaust manifold	29	300	22
Exhaust manifold x Cylinder head	49	500	36
Exhaust manifold stay x WU-TWC	42	425	31
Exhaust manifold stay x FR engine mounting insulator	42	425	31
No. 1 exhaust manifold stay x WU-TWC	42	425	31
No. 1 exhaust manifold stay x Cylinder block	42	425	31
Main bearing cap x Cylinder block	59	600	43
Connecting rod cap x Connecting rod (1 st)	25	250	18
Connecting rod cap x Connecting rod (2nd)	Turn 90°		
No. 1 balance shaft housing x No. 2 balance shaft housing (1st)	22	220	16
No. 1 balance shaft housing x No. 2 balance shaft housing (2nd)	Turn 90°		
Engine balancer x Cylinder block	49	500	36
Rear oil seal retainer x Cylinder block	9.3	95	82 in.-lbf
Knock sensor x Cylinder block	37	380	27
PS pump bracket x Cylinder block	43	440	32
Rear end plate x Cylinder block	9.3	95	82 in.-lbf
Flywheel x Crankshaft (M/T)	88	900	65
Drive plate x Crankshaft (A/T)	83	850	61
RR engine mounting insulator x Cylinder block	84	650	47
FR engine mounting insulator x Cylinder block	77	790	57
FR engine mounting insulator x Front suspension member	80	820	59
RR engine mounting insulator x Front suspension member	86	670	48
LH engine mounting insulator x Transaxle	84	650	47
PS pump x PS pump bracket	43	440	31
Front exhaust pipe x WU-TWC	62	630	46
A/C compressor x Cylinder block	27	280	20
Fuel inlet hose x Fuel filter (Union bolt)	29	300	22